

CONTENTS

American National Standards

Project Initiation Notification System (PINS)	2
Call for Comment on Standards Proposals	11
Final Actions - (Approved ANS)	57
Call for Members (ANS Consensus Bodies).....	60
Call for Comment of ANS Limited Substantive Changes	72
American National Standards (ANS) Announcements.....	74
Accreditation Announcements (Standards Developers).....	75
American National Standards (ANS) Process	79
ANS Under Continuous Maintenance	80
ANSI-Accredited Standards Developer Contact Information.....	81

International Standards

ISO Draft Standards.....	85
ISO and IEC Newly Published Standards	86
International Organization for Standardization (ISO)	88

Registration of Organization Names in the United States

89

Proposed Foreign Government Regulations

90

Project Initiation Notification System (PINS)

ANSI Procedures require notification of ANSI by ANSI-accredited standards developers (ASD) of the initiation and scope of activities expected to result in new or revised American National Standards (ANS). Early notification of activity intended to reaffirm or withdraw an ANS and in some instances a PINS related to a national adoption is optional. The mechanism by which such notification is given is referred to as the PINS process. For additional information, see clause 2.4 of the ANSI Essential Requirements: Due Process Requirements for American National Standards.

Following is a list of proposed actions and new ANS that have been received recently from ASDs. Please also review the section in Standards Action entitled "American National Standards Maintained Under Continuous Maintenance" for additional or comparable information with regard to standards maintained under the continuous maintenance option. Use the following Public Document Library url to access PDF & EXCEL reports of approved & proposed ANS: [List of Approved and Proposed ANS](#)

Directly and materially affected interests wishing to receive more information or to submit comments are requested to contact the standards developer directly within 30 days of the publication of this announcement.

AAMI (Association for the Advancement of Medical Instrumentation)

901 N. Glebe Road, Suite 300, Arlington, VA 22203 www.aami.org

Contact: Colleen Elliott; celliott@aami.org

National Adoption

BSR/AAMI/ISO 80369-1-202x, Small-bore connectors for liquids and gases in healthcare applications - Part 1: General requirements (identical national adoption of ISO 80369-1 (Ed 3) and revision of ANSI/AAMI/ISO 80369-1-2018)

Stakeholders: Medical device manufacturers, clinicians, regulators.

Project Need: The proposed revision to ISO 80369-1 is to provide a process for manufacturers of medical devices whose application area is not currently addressed by the ISO 80369 series to incorporate a connector design utilizing a 6% Luer taper that conforms to the requirements of ISO 80369-7, Clause 6. This change requires the manufacturer to carry out a risk assessment to demonstrate that the risk of unintended connection between the application areas envisioned is acceptably low, as accomplished through a required risk analysis.

Scope: This document specifies general requirements for small-bore connectors, which convey liquids or gases in healthcare applications. These small-bore connectors are used in medical devices or accessories intended for use with a patient. This document also specifies the healthcare fields in which these small-bore connectors are intended to be used. These healthcare fields include, but are not limited to:

- breathing systems and driving gases;
- enteral;
- limb cuff inflation;
- neuraxial;
- intravascular or hypodermic.

This document provides the methodology to assess non-interconnectable characteristics of small-bore connectors based on their inherent design and dimensions in order to reduce the risk of misconnections between medical devices or between accessories for different applications as specified in this document as well as those that will be developed under future parts of the ISO 80369 series.

AAMI (Association for the Advancement of Medical Instrumentation)

901 N. Glebe Road, Suite 300, Arlington, VA 22203 www.aami.org

Contact: Colleen Elliott; celliott@aami.org

National Adoption

BSR/AAMI/ISO 80369-20-202x, Small-bore connectors for liquids and gases in healthcare applications - Part 20: Common test methods (identical national adoption of ISO 80369-20 (Ed 2) and revision of ANSI/AAMI/ISO 80369-20-2015)

Stakeholders: Medical device manufacturers, clinicians, regulators.

Project Need: Now that the test methods have been in use for 5 years, improvements can be made to the standard.

Scope: Specifies the test methods to evaluate the performance requirements for small-bore connectors specified in the ISO 80369 series.

ASABE (American Society of Agricultural and Biological Engineers)

2950 Niles Road, Saint Joseph, MI 49085 <https://www.asabe.org/>

Contact: Carla VanGilder; vangilder@asabe.org

National Adoption

BSR/ASABE/ISO 24347-202x, Agricultural vehicles - Mechanical connections between towed and towing vehicles - Dimensions of ball-type coupling device (80 mm) (identical national adoption of ISO 24347:2019 and revision of ANSI/ASABE AD24347:2014 (R2018))

Stakeholders: Agricultural equipment manufacturers.

Project Need: Align ASABE adoption with 2019 version of ISO 24347.

Scope: This document specifies the dimensional requirements and location for a ball coupling device of 80-mm nominal diameter, whose male part is fitted to an agricultural towing vehicle and female part is fitted to a towed, non-balanced vehicle which provides mechanical connection between the two vehicles. It defines vertical loading for different positions. This document specifies a ball coupling device with either a horizontal adjustable version, or a close position version.

ASME (American Society of Mechanical Engineers)

Two Park Avenue, M/S 6-2B, New York, NY 10016-5990 www.asme.org

Contact: Terrell Henry; ansibox@asme.org

Revision

BSR/ASME PTC-51-202x, Gas Turbine Inlet Air-Conditioning Equipment (revision of ANSI/ASME PTC 51-2011 (R2016))

Stakeholders: Gas turbine owners, manufacturers, testing services, regulators.

Project Need: To provide updated requirements and references in the ASME PTC 51 Standard.

Scope: This Code provides procedures for in situ testing of inlet air-conditioning systems (cooling/heating) as they apply to gas turbines in simple, co-generation, and combined-cycle applications.

ASTM (ASTM International)

100 Barr Harbor Drive, West Conshohocken, PA 19428-2959 www.astm.org

Contact: Laura Klineburger; accreditation@astm.org

New Standard

BSR/ASTM WK76344-202x, Reinstatement of F628 - 12e3 Standard Specification for Acrylonitrile-Butadiene-Styrene (ABS) Schedule 40 Plastic Drain, Waste, and Vent Pipe with a Cellular Core (new standard)

Stakeholders: DWV industry.

Project Need: This standard is referenced in plumbing codes in both the US and Canada. Also there are multiple manufacturers that are still producing pipe according to this withdrawn standard.

Scope: This specification covers coextruded acrylonitrile-butadiene-styrene (ABS) plastic drain, waste, and vent pipe made to Schedule 40 iron pipe sizes (IPS) and produced by the coextrusion process with concentric inner and outer solid ABS layers and the core consisting of closed-cell cellular ABS. Plastic, which does not meet the material requirements specified in Section 5, is excluded from single-layer and all coextruded layers.

AWC (American Wood Council)

222 Catoctin Circle , Suite 201, Leesburg, VA 20175 www.awc.org

Contact: Bradford Douglas; bdouglas@awc.org

Revision

BSR/AWC NDS-2024-202x, National Design Specification® for Wood Construction (revision and redesignation of ANSI/AWC NDS-2018)

Stakeholders: Wood products producers, designers, and regulators.

Project Need: This specification provides standardized requirements for structural and fire design of wood products, and their connectors.

Scope: Revise current version of ANS/NDS-2018, primarily to update provisions to latest state-of-the-art wood engineering.

AWC (American Wood Council)

222 Catoctin Circle , Suite 201, Leesburg, VA 20175 www.awc.org

Contact: Bradford Douglas; bdouglas@awc.org

Revision

BSR/AWC WFCM-2024-202x, Wood Frame Construction Manual for One- and Two-Family Dwellings (revision and redesignation of ANSI/AWC WFCM-2018)

Stakeholders: Engineers, architects, builders, and regulators.

Project Need: The WFCM provides engineered and prescriptive design requirements for wood frame construction used in one- and two-family dwellings constructed in high-wind, seismic, and snow regions.

Scope: Revise ANSI/AWC WFCM-2018, primarily to address anticipated changes to wind load provisions in ASCE 7-22.

AWWA (American Water Works Association)

6666 W. Quincy Avenue, Denver, CO 80235 www.awwa.org

Contact: Paul Olson; polson@awwa.org

New Standard

BSR/AWWA B1YY-202x, Ion Exchange Resin (new standard)

Stakeholders: Drinking water treatment and supply industry; Water utilities, consulting engineers, water treatment equipment manufacturers, etc.

Project Need: Ion exchange has been used successfully around the country and the world for many years for the removal of undesirable anions or cations and, as a treatment technique, is increasing in use to address many constituents. Currently, AWWA does not have any ion exchange resin standards that could aid water purveyors, design engineers, and treatment staff with resin selection, resin storage, vessel loading rates, resin and vessel disinfection, resin regeneration (salt, acid, etc.), and constituent removal rates and performance.

Scope: The standard will set minimum standards for ion exchange (IX) media and equipment. This standard is intended to assist with the design, procurement, installation, and commissioning of IX systems. The standard will cover synthetically manufactured ion exchange media typically polymer-based in bead form and softening and nitrate treatments.

ECIA (Electronic Components Industry Association)

13873 Park Center Road, Suite 315, Herndon, VA 20171 www.ecianow.org

Contact: Laura Donohoe; ldonohoe@ecianow.org

Revision

BSR/EIA 887-B-202x, Thin Film Resistor Network Specification (revision and redesignation of ANSI/EIA 887-A-2015)

Stakeholders: Electrical, electronic, and telecommunications industries.

Project Need: Revise and redesignate the current American National Standard.

Scope: This specification defines the requirements for a family of thin film resistor networks on silicon with various configurations, packaged in a molded, JEDEC-approved package.

FCI (Fluid Controls Institute)

1300 Sumner Avenue, Cleveland, OH 44115 www.fluidcontrolsinstitute.org

Contact: Leslie Schraff; fci@fluidcontrolsinstitute.org

Revision

BSR/FCI 13-1-202x, Standard for Determining Condensate Loads to Size Steam Traps (revision of ANSI/FCI 13-1-2016)

Stakeholders: Manufacturers, users, specifiers of steam trap equipment.

Project Need: It is intended to assist users in estimating condensate loads using generally accepted formulas. The result is then used to size a steam trap with sufficient safety factor to cover the flow throughout the range without being grossly oversized.

Scope: The purpose of this standard is to help estimate condensate loads using generally accepted formulas. The result is then used to size a steam trap with sufficient safety factor to discharge the necessary flow throughout the positive pressure differential range without being grossly oversized. A properly sized steam trap can help provide reliable and efficient function.

FM (FM Approvals)

1151 Boston-Providence Turnpike, Norwood, MA 02062 www.fmglobal.com

Contact: Josephine Mahnken; josephine.mahnken@fmaprovals.com

New Standard

BSR/FM 4430-202x, Heat and Smoke Vents (new standard)

Stakeholders: Commercial and industrial building end users, building code officials, AHJ's, manufacturers, architects, consultants, loss-prevention engineers, insurance companies/agencies.

Project Need: To establish an American National Standard for Heat and Smoke Vents.

Scope: This standard sets the performance requirements for heat and smoke vents under simulated laboratory conditions. They shall be examined for their ability to not vent until such time as sprinklers would have been expected to operate so as not to adversely affect the sprinkler operation. Additionally, this standard also sets their performance requirements when exposed to various natural hazards such as high wind events, the impact of hail, and the possible degradation effects of sunlight. The standard also examines their ability to withstand the impact effects of temporary live loads as well as to be able to operate under anticipated roof live (snow) loads. This standard is intended to evaluate only those hazards investigated and is not intended to determine suitability for the end use of the product.

FM (FM Approvals)

1151 Boston-Providence Turnpike, Norwood, MA 02062 www.fmglobal.com

Contact: Josephine Mahnken; josephine.mahnken@fmaprovals.com

New Standard

BSR/FM 4431-202x, Skylights (new standard)

Stakeholders: Commercial/Industrial building end users, building code officials, manufacturers, architects, consultants loss-prevention engineers, insurance agencies.

Project Need: To establish an American National Standard for Skylights.

Scope: This standard sets the performance requirements for skylights under simulated laboratory conditions. They shall be examined for their ability to limit fire propagation over and/or through the assembly when exposed to an ignition source simulating an exterior building fire. This standard also sets the performance requirements for skylights when exposed to various natural hazards such as high wind events, the impact of simulated hail or windborne debris, and the possible degradation effects of sunlight. The standard also examines the ability of the skylights to withstand the effects of temporary live loads such as those imposed by foot traffic. This standard is intended to evaluate only those hazards investigated and is not intended to determine suitability for the end use of the product.

FM (FM Approvals)

1151 Boston-Providence Tpke, Norwood, MA 02062 www.fmglobal.com

Contact: Patrick Byrne; patrick.byrne@fmaprovals.com

New Standard

BSR/FM2500-202x, Examination Standard for Early Warning Flood Sensor Systems (new standard)

Stakeholders: Building code officials, manufacturers, architects, consultants, loss-prevention engineers, insurance agencies.

Project Need: This standard provides approval requirements for sensors used to provide early warning flood notification from telemetry systems deployed within a coverage area.

Scope: This standard applies to systems that measure water elevations (i.e., static and rate-of-change types), rainfall, water flow, presence of water, soil moisture, etc. This standard applies to telemetry systems that automatically sense and transmit data on programmed intervals. The equipment in this standard may include multiple sensors. Sensor types not included in the scope of this standard are to be included in the evaluation of Power Systems for the equipment. Communication between the individual node or gateway to the Internet of Things (IoT) may be accomplished using industry protocols (i.e., ALERT, ALERT2, etc.) and/or proprietary software. Telemetry systems used in this standard support the bidirectional transmission of sensor data via network topographies such as direct communication, node to node, mesh, star, etc. Systems may incorporate one or multiple technologies to ensure ability to transmit and receive data. The equipment included in this standard may be powered by one or more means such as: electrical service, secondary (rechargeable) battery with solar panel, or by primary (non-rechargeable) battery. The equipment included in this standard may be standalone or housed within one or multiple enclosures to protect the components from the environment.

IES (Illuminating Engineering Society)

120 Wall Street, Floor 17, New York, NY 10005 www.ies.org

Contact: Patricia McGillicuddy; pmcgillicuddy@ies.org

New Standard

BSR/IES TM-3x-202x, Technical Memorandum: Discomfort Glare under Low Light Conditions (new standard)

Stakeholders: Lighting practitioners, engineers, architects, environmentalists, regulatory agencies, luminaire manufacturers and test labs, the general public.

Project Need: Create TM which becomes the official cited document on Discomfort Glare. Since the first papers written on glare, people have debated the topic and today the IES is still without a published position on how to predict, evaluate, and measure discomfort glare which the public can use to determine what is deemed acceptable. The TM will provide users the definition, evaluation metrics, methods for predicting and measuring discomfort glare in outdoor nighttime environments. These environments include, but are not limited to: parking lots, pedestrian areas, and sporting facilities.

Scope: This document is limited to evaluation and measurement of discomfort glare from small sources in outdoor nighttime environments (luminance levels from applications) including, but not limited to, parking lots, garages, pedestrian areas, and sporting facilities (roadway?). Effects such as multiple sources, spectral effects and non-uniformity are not discussed in this document.

IES (Illuminating Engineering Society)

120 Wall Street, Floor 17, New York, NY 10005 www.ies.org

Contact: Patricia McGillicuddy; pmcgillicuddy@ies.org

New Standard

BSR/IES TM-202x- (Resilient Lighting), Technical Memorandum: Introduction to Resilient Lighting Systems (new standard)

Stakeholders: Lighting practitioners, engineers, architects, building owners, occupants, luminaire manufacturers and test labs, regulatory agencies, the general public.

Project Need: The scope of this LP does not include emergency lighting for the purpose of evacuation and marking of egress paths, since building codes already dictate these needs. In addition, this document is not intended for the development of emergency plans or courses of action during extreme events. For example, determining when to evacuate a building or whether to shelter in place is determined by local authorities.

Scope: For the purpose of this document, resilient design is defined as the ability to prepare and plan for, absorb, recover from, and more successfully adapt to adverse events. Emergency planning is not a new undertaking. However, with such high-profile events as Hurricane Katrina, Superstorm Sandy, and the COVID-19 pandemic, focused efforts to understand how the built environment can incorporate resiliency into homes, buildings, and infrastructure is a distinct goal. The purpose of this Lighting Practice document (LP) is to introduce the concept of resilient design and explain how lighting systems can support the goals of enhancing the resilience of buildings. The intent is to provide guidance on lighting performance, controls, and the characteristics of lighting equipment for resilient buildings.

ROHVA (Recreational Off-Highway Vehicle Association)

2 Jenner Street, Suite 150, Irvine, CA 92618

Contact: Ken Glaser; kglaser@rohva.org

Revision

BSR/ROHVA 1-202x, Recreational Off-Highway Vehicles (revision of ANSI/ROHVA 1-2016)

Stakeholders: Manufacturers/distributors, users/user associations, general interest, government agency.

Project Need: Maintenance to and revision of a voluntary standard (ANSI/ROHVA 1-2016) addressing design, configuration, and performance aspects of ROVs.

Scope: This standard addresses design, configuration, and performance aspects of ROVs, including, among other items, requirements for accelerator, clutch, and gearshift controls; lighting; tires; service and parking brake/parking mechanism performance; lateral and pitch stability; occupant handholds; Roll Over Protective Structure (ROPS); Occupant Retention System (ORS); and requirements for labels and owner's manual.

SCTE (Society of Cable Telecommunications Engineers)

140 Philips Rd, Exton, PA 19341 www.scte.org

Contact: Kim Cooney; kcooney@scte.org

Revision

BSR/SCTE 224-202x, Event Scheduling and Notification Interface (ESNI) (revision of ANSI/SCTE 224-2020)

Stakeholders: Cable Telecommunications industry.

Project Need: Update current technology.

Scope: This document defines the Event Scheduling and Notification Interface (ESNI), which is a web interface facilitating the transmission of event and policy information. ESNI provides a functional method for providers to communicate upcoming schedule or signal-based events and corresponding policy to distributors. This interface allows existing content distribution controls traditionally performed via manual control in IRD's by providers to be replaced with a programmatic interface (this standard). ESNI policy enables control of content distributed to audiences based on attributes of that audience including (but not limited to) geographic location and device type.

SVIA (Specialty Vehicle Institute of America)

2 Jenner, Suite 150, Irvine, CA 92618

Contact: Ken Glaser; kglaser@svia.org

Revision

BSR/SVIA 1-202x, Four Wheel All-Terrain Vehicles (revision of ANSI/SVIA 1-2017)

Stakeholders: Manufacturers/distributors, users/user associations, general interest, government agency.

Project Need: Maintenance to and revision of a voluntary standard (ANSI/SVIA 1-2017) addressing design, configuration, and performance aspects of ATVs.

Scope: This standard addresses design, configuration, and performance aspects of Four-Wheel All-Terrain Vehicles (ATVs), including, among other items, requirements for mechanical suspension; throttle, clutch and gearshift controls; engine and fuel cutoff devices; lighting; tires; operator foot environment; service and parking brake/parking mechanism performance; and pitch stability. Other areas covered in this standard include: defining Type I and Type II ATVs; Youth and T category ATVs; requirements for Type II ATVs; requirements for labels, owner's manuals, and hang tags; and a compliance certification label.

TCNA (ASC A108) (Tile Council of North America)

100 Clemson Research Blvd., Anderson, SC 29625 www.tcnatile.com

Contact: Katelyn Simpson; KSimpson@tileusa.com

New Standard

BSR A108.M-202x, General Requirements: Materials and Standards for the Installation of Tile (new standard)

Stakeholders: Ceramic tile installers, contractors, and builders (labor interest category); related material manufacturers (manufacturing interest category); distributors, retailers and consumers (user interest category); and affiliated industries and other general interest users of this standard (general interest category).

Project Need: Various stakeholders have suggested that a new standard be created to provide a list of relevant standards and materials for the installation of tile.

Scope: These ANSI specifications are intended to describe a general list of materials required for the installation of ceramic and glass tile and a list of standards for structures, substrates, and materials for the installation of tile.

TCNA (ASC A108) (Tile Council of North America)

100 Clemson Research Blvd., Anderson, SC 29625 www.tcnatile.com

Contact: Katelyn Simpson; KSimpson@tileusa.com

New Standard

BSR A108.T-202x, Standard Terminology of Tile Assemblies (new standard)

Stakeholders: Ceramic tile installers, contractors, and builders (labor interest category); related material manufacturers (manufacturing interest category); distributors, retailers, and consumers (user interest category); and affiliated industries and other general interest users of this standard (general interest category).

Project Need: Various stakeholders have suggested that a new standard be created to provide a list of terms and definitions associated with the installation of ceramic tile.

Scope: This American National Standard is intended to list and define terms commonly used in the ANSI product and installation standards for ceramic tile (A137.X, A108.X, and A118.X). The terminology and definitions provided in this standard are intended to unify and support information across all the American National Standards for tile.

TIA (Telecommunications Industry Association)

1320 North Courthouse Road, Suite 200, Arlington, VA 22201 www.tiaonline.org

Contact: Teesha Jenkins; standards-process@tiaonline.org

Reaffirmation

BSR/TIA 1152-A-2016 (R202x), Requirements for Field Test Instruments and Measurements for Balanced Twisted-Pair Cabling (reaffirmation of ANSI/TIA 1152-A-2016)

Stakeholders: Field tester manufacturers; Test equipment manufacturers; Structured cabling products manufacturers; Structured cabling installers.

Project Need: Reaffirm standard.

Scope: Reaffirm ANSI/TIA 1152-2009 as determined in TIA TR-42.7, incorporating new specifications and other information as required to support field testing of cabling described in ANSI/TIA 568-C.2-1.

Call for Comment on Standards Proposals

American National Standards

This section solicits public comments on proposed draft new American National Standards, including the national adoption of ISO and IEC standards as American National Standards, and on proposals to revise, reaffirm or withdraw approval of existing American National Standards. A draft standard is listed in this section under the ANSI-accredited standards developer (ASD) that sponsors it and from whom a copy may be obtained. Comments in connection with a draft American National Standard must be submitted in writing to the ASD no later than the last day of the comment period specified herein. Such comments shall be specific to the section(s) of the standard under review and include sufficient detail so as to enable the reader to understand the commenter's position, concerns and suggested alternative language, if appropriate. Please note that the ANSI Executive Standards Council (ExSC) has determined that an ASD has the right to require that interested parties submit public review comments electronically, in accordance with the developer's procedures.

Ordering Instructions for "Call-for-Comment" Listings

1. Order from the organization indicated for the specific proposal.
2. Use the full identification in your order, including the BSR prefix; for example, Electric Fuses BSR/SAE J554.
3. Include remittance with all orders.
4. BSR proposals will not be available after the deadline of call for comment.

Comments should be addressed to the organization indicated, with a copy to the Board of Standards Review, American National Standards Institute, 25 West 43rd Street, New York, NY 10036. e-mail: psa@ansi.org

* Standard for consumer products

Comment Deadline: May 9, 2021

ASHRAE (American Society of Heating, Refrigerating and Air-Conditioning Engineers, Inc.)

180 Technology Parkway, Peachtree Corners, GA 30092 p: (404) 636-8400 w: www.ashrae.org

Addenda

BSR/ASHRAE Addendum a to Standard 41.10-202x, Standard Methods for Refrigerant Mass Flow Rate Measurements Using Flowmeters (addenda to ANSI/ASHRAE Standard 41.10-2020)

This addendum adds a new definition to Section 3 and revises Sections 5 and 7.4.2.

[Click here to view these changes in full](#)

Send comments (with optional copy to psa@ansi.org) to: <http://www.ashrae.org/standards-research--technology/public-review-drafts>

NSF (NSF International)

789 N. Dixboro Road, Ann Arbor, MI 48105-9723 p: (734) 827-3817 w: www.nsf.org

Revision

BSR/NSF 25-202x (i18r1), Vending Machines for Food and Beverages (revision of ANSI/NSF 25-2017)

This Standard contains requirements for food and beverage vending machines, including those that vend packaged food and beverages and those that vend food and beverages in bulk.

[Click here to view these changes in full](#)

Send comments (with optional copy to psa@ansi.org) to: Allan Rose; arose@nsf.org

UL (Underwriters Laboratories)

12 Laboratory Drive, P.O. Box 13995, Research Triangle Park, NC 27709-3995 p: (919) 549-1391 w: <https://ul.org/>

Reaffirmation

BSR/UL 1450-2019 (R202x), Standard for Safety for Motor-Operated Air Compressors, Vacuum Pumps, and Painting Equipment (reaffirmation of ANSI/UL 1450-2019)

The following changes in requirements are being proposed for your review: (1) Revision of cord tag requirements; and (2) Update of standard reference for ultraviolet light test.

[Click here to view these changes in full](#)

Send comments (with optional copy to psa@ansi.org) to: Follow the instructions in the following website to enter comments into the CSDS Work Area: <https://csds.ul.com/Home/ProposalsDefault.aspx>

Comment Deadline: May 9, 2021

UL (Underwriters Laboratories)

333 Pfingsten Road, Northbrook, IL 60062-2096 p: (847) 664-1725 w: <https://ul.org/>

Revision

BSR/UL 5800-202x, Standard for Safety for Battery Fire Containment Products (revision of ANSI/UL 5800-2020)

(1) Editorial Revisions to Clauses 4.2, 8.2.3, 8.2.5, 8.2.6, 8.2.10, Figure 8.1, and Figure 8.2.

[Click here to view these changes in full](#)

Send comments (with optional copy to psa@ansi.org) to: Follow the instructions in the following website to enter comments into the CSDS Work Area: <https://csds.ul.com/Home/ProposalsDefault.aspx>

Comment Deadline: May 24, 2021

AAFS (American Academy of Forensic Sciences)

410 North 21st Street, Colorado Springs, CO 80904 p: (719) 453-1036 w: www.aafs.org

New Standard

BSR/ASB Std 123-202x, Standard for Routine Internal Evaluation of a Laboratory's DNA Interpretation and Comparison Protocol (new standard)

This standard provides the requirements for the technical leader (or appropriate personnel) to: (1) routinely evaluate the consistent application of the developed, verified and implemented DNA interpretation and comparison protocol within a laboratory and laboratory system; and (2) assess whether the DNA interpretation and comparison protocol is appropriately and consistently used to produce reliable and reproducible interpretations and comparisons. This standard addresses the development of an internal evaluation system, including proper format of data, types of data to use, frequency of evaluation, and how to assess results. This standard applies directly to capillary electrophoresis-based STR DNA testing, but may also be applied as appropriate to laboratories using other test methods. This standard applies to manual/binary interpretation and comparison methods as well as methods using software as part of the analysis, interpretation, comparison, and/or for generation of statistical statements.

Single copy price: Free

Obtain an electronic copy from: Document and comments template can be viewed on the AAFS Standards Board website at: <http://www.asbstandardsboard.org/notice-of-standard-development-and-coordination//>

Order from: Document will be provided electronically on AAFS Standards Board website (www.asbstandardsboard.org) free of charge.

Send comments (with optional copy to psa@ansi.org) to: asb@aafs.org

ASA (ASC S1) (Acoustical Society of America)

1305 Walt Whitman Road, Suite 300, Melville, NY 11747 p: (516) 576-2341 w: www.acousticalsociety.org

National Adoption

BSR/ASA S1.15, Part 1-202x/IEC 61094-1-2000, Electroacoustics - Measurement microphones - Part 1: Specifications for laboratory standard microphones (identical national adoption of IEC 61094-1:2000)

This standard specifies mechanical dimensions and certain electroacoustic characteristics for condenser microphones used as laboratory standards for the realization of the unit of sound pressure and for sound pressure measurements of the highest attainable accuracy. The specifications are intended to ensure that primary calibration by the reciprocity method can be readily carried out. This standard also establishes a system for classifying laboratory standard condenser microphones into a number of types according to their dimensions and properties.

Single copy price: \$60.00

Obtain an electronic copy from: standards@acousticalsociety.org

Order from: Nancy Blair-DeLeon; standards@acousticalsociety.org

Send comments (with optional copy to psa@ansi.org) to: Nancy Blair-DeLeon; standards@acousticalsociety.org

Comment Deadline: May 24, 2021

ASA (ASC S1) (Acoustical Society of America)

1305 Walt Whitman Road, Suite 300, Melville, NY 11747 p: (516) 576-2341 w: www.acousticalsociety.org

National Adoption

BSR/ASA S1.15, Part 2-202x/IEC 61094-2-202x, Electroacoustics - Measurement microphones - Part 2: Primary method for pressure calibration of laboratory standard microphones by the reciprocity technique (identical national adoption of IEC 61094-2:2009 and revision of ANSI/ASA S1.15-2005/Part 2 (R2020))

This part of International Standard IEC 61094 is applicable to laboratory standard microphones meeting the requirements of IEC 61094-1 and other types of condenser microphones having the same mechanical dimensions; specifies a primary method of determining the complex pressure sensitivity so as to establish a reproducible and accurate basis for the measurement of sound pressure. All quantities are expressed in SI units.

Single copy price: \$208.00

Obtain an electronic copy from: standards@acousticalsociety.org

Order from: Nancy Blair-DeLeon; standards@acousticalsociety.org

Send comments (with optional copy to psa@ansi.org) to: Nancy Blair-DeLeon; standards@acousticalsociety.org

ASABE (American Society of Agricultural and Biological Engineers)

2950 Niles Road, Saint Joseph, MI 49085 p: (269) 757-1213 w: <https://www.asabe.org/>

New Standard

BSR/ASABE EP653 MONYEAR-202x, Heating, Ventilating, and Air Conditioning (HVAC) for Indoor Plant Environments without Sunlight (new standard)

This Engineering Practice provides growers with the foundational information that will (a) facilitate the understanding of HVAC equipment options that can be used to manage the indoor plant environment (IPE) and (b) allow the grower to communicate knowledgeably with engineers, contractors, manufacturers, investors, and other growers.

Single copy price: \$72.00

Obtain an electronic copy from: walsh@asabe.org

Order from: Jean Walsh; walsh@asabe.org

Send comments (with optional copy to psa@ansi.org) to: Jean Walsh; walsh@asabe.org

ASABE (American Society of Agricultural and Biological Engineers)

2950 Niles Road, Saint Joseph, MI 49085 p: (269) 932-7015 w: <https://www.asabe.org/>

Revision

BSR/ASABE S648-4.1-202x, Agricultural Field Equipment Braking - Part 4: Requirements for Towed Vehicles (revision and redesignation of ANSI/ASABE S648-4 MONYEAR-2020)

The purpose of this part of ANSI/ASABE S648, when used in conjunction with ANSI/ASABE S648-1, is to define the minimum requirements related to braking of towed agricultural field equipment. Braking includes service braking in transport conditions and parking brake in field conditions. This standard provides normative references and establishes the minimum requirements related to braking of towed vehicles and towed vehicle trains. These requirements and minimum performance criteria are directed to the operation and parking of towed vehicles and towed vehicle trains having a maximum design ground speed greater than 6 km/h (3.7 mile/h).

Single copy price: ASABE Members: \$49.00; Non ASABE Members: \$72.00

Obtain an electronic copy from: vangilder@asabe.org

Order from: Carla VanGilder; vangilder@asabe.org

Send comments (with optional copy to psa@ansi.org) to: Carla VanGilder; vangilder@asabe.org

Comment Deadline: May 24, 2021

ASABE (American Society of Agricultural and Biological Engineers)

2950 Niles Road, Saint Joseph, MI 49085 p: (269) 932-7015 w: <https://www.asabe.org/>

Revision

BSR/ASABE S648-5.1 MONYEAR-202x, Agricultural Field Equipment Braking - Part 5: Requirements for the Interface between Towing Vehicle and Towed Vehicles (revision and redesignation of ANSI/ASABE S648-5 MAR2020)

The purpose of this standard, when used in conjunction with ANSI/ASABE S648-1, is to define the requirements for interfacing towing vehicle service and parking brakes with towed vehicles with a service brake system, a parking brake system or both. This part of ANSI/ASABE S648 establishes the minimum requirements for interfacing the service brake system and parking brake system on towing agricultural field equipment with the service brake system and parking brake system on towed agricultural field equipment. The requirements are applicable to dual-line hydraulic and pneumatic systems but does not preclude the use of other equivalent systems. These requirements and minimum performance criteria are directed to the operation and parking of agricultural field equipment having a maximum design ground speed greater than 6 km/h (3.7 mile/h).

Single copy price: ASABE Members: \$49.00; Non-ASABE Members: \$72.00

Obtain an electronic copy from: vangilder@asabe.org

Order from: Carla VanGilder; vangilder@asabe.org

Send comments (with optional copy to psa@ansi.org) to: Carla VanGilder; vangilder@asabe.org

ASHRAE (American Society of Heating, Refrigerating and Air-Conditioning Engineers, Inc.)

180 Technology Parkway, Peachtree Corners, GA 30092 p: (404) 636-8400 w: www.ashrae.org

Revision

BSR/ASHRAE Standard 118.2-202x, Method of Testing for Rating Residential Water Heaters and Residential-Duty Commercial Water Heaters (revision of ANSI/ASHRAE Standard 118.2-2006)

This revision of Standard 118.2-2006 provides test procedures for rating the efficiency and hot water delivery capabilities of directly heated residential water heaters and residential-duty commercial water heaters.

Single copy price: \$35.00

Obtain an electronic copy from: <http://www.ashrae.org/standards-research--technology/public-review-drafts>

Order from: standards.section@ashrae.org

Send comments (with optional copy to psa@ansi.org) to: <http://www.ashrae.org/standards-research--technology/public-review-drafts>

ASQ (ASC Z1) (American Society for Quality)

600 N Plankinton Avenue, Milwaukee, WI 53203 p: (800) 248-1946 w: www.asq.org

National Adoption

BSR/ASQ/ISO/TS 54001-202x, Quality management systems - Particular requirements for the application of ISO 9001:2015 for electoral organizations at all levels of government (identical national adoption of ISO/TS 54001:2019)

This document specifies requirements for a quality management system where an electoral organization:

- needs to demonstrate its ability to manage elections by secret ballot, to provide reliable, transparent, free and fair results that comply with electoral requirements;
- within the established legal framework, aims to enhance the trust and confidence of citizens, candidates, political organizations and other electoral interested parties through the effective implementation of the electoral quality management system, including processes for continual improvement.

Single copy price: \$209.00

Obtain an electronic copy from: <https://asq.org/quality-press/display-item?item=T1564E>

Send comments (with optional copy to psa@ansi.org) to: standards@asq.org

Comment Deadline: May 24, 2021

AWS (American Welding Society)

8669 NW 36th Street, Suite 130, Miami, FL 33166-6672 p: (305) 443-9353 306 w: www.aws.org

Revision

BSR/AWS A5.31M/A5.31-202x, Specification for Fluxes for Brazing and Braze Welding (revision of ANSI/AWS A5.31M/A5.31-2012)

This specification prescribes the requirements for classification of eighteen fluxes for brazing and braze welding. They are classified according to the filler metal, form, and activity temperature range. Classification is in accordance with a classification system that employs the designator "FB" to indicate fluxes for brazing and braze welding applications. In addition to selected tests for each classification, major topics include general requirements, testing procedures, and packaging requirements. A guide is appended to the specification as a source of information concerning the classification system employed and the intended use of the brazing fluxes. This specification makes use of both U.S. Customary Units and the International System of Units (SI). Since these are not equivalent, each system must be used independently of the other.

Single copy price: \$36.00 (non-members)/\$26.00 (AWS members)

Obtain an electronic copy from: kbulger@aws.org

Order from: Kevin Bulger; kbulger@aws.org

Send comments (with optional copy to psa@ansi.org) to: Kevin Bulger; kbulger@aws.org

AWWA (American Water Works Association)

6666 W. Quincy Avenue, Denver, CO 80235 p: (303) 347-6178 w: www.awwa.org

Revision

BSR/AWWA C906-202x, Polyethylene (PE) Pressure Pipe and Fittings, 4 In. through 65 In. (100 mm through 1,650 mm), for Waterworks (revision of ANSI/AWWA C906-2014)

This standard describes polyethylene (PE) pressure pipe and fittings made from materials conforming to standard PE materials designation code PE 4710.

Single copy price: Free

Obtain an electronic copy from: ETSupport@awwa.org

Order from: Vicki David; vdavid@awwa.org

Send comments (with optional copy to psa@ansi.org) to: Paul Olson; polson@awwa.org

B11 (B11 Standards, Inc.)

P.O. Box 690905, Houston, TX 77269 p: (832) 446-6999 w: <https://www.b11standards.org/>

Revision

BSR/B11.3-202x, Safety Requirements for Power Press Brakes (revision of ANSI B11.3-2012 (R2020))

The requirements of this standard apply to those machines classified as power press brakes (referred to simply as "press brakes" in this standard), which are designed and constructed for the specific purpose of bending material.

Single copy price: \$99.00

Obtain an electronic copy from: cfelinski@b11standards.org

Send comments (with optional copy to psa@ansi.org) to: dfelinski@b11standards.org

HI (Hydraulic Institute)

300 Interpace Parkway, Building A, 3rd Floor, Parsippany, NJ 07054 p: (862) 226-2055 w: www.pumps.org

Reaffirmation

BSR/HI 5.1-5.6-2016 (R202x), Sealless Rotodynamic Pumps for Nomenclature, Definitions, Design, Application, Operation, and Test (reaffirmation of ANSI/HI 5.1-5.6-2016)

This standard covers the specifics of sealless rotodynamic pumps: frequent terms, definitions of pump types, design specifications, operation of pumps, and testing of pumps. The 2016 publication was reviewed by committee which voted to reaffirm the 2016 standard with minor edits made to the titles of figures to align with figures within ANSI/HI 14.1-14.2.

Single copy price: \$90.00

Obtain an electronic copy from: Amy Sisto; asisto@pumps.org

Send comments (with optional copy to psa@ansi.org) to: Amy Sisto; asisto@pumps.org

Comment Deadline: May 24, 2021

IES (Illuminating Engineering Society)

120 Wall Street, Floor 17, New York, NY 10005 p: (917) 913-0027 w: www.ies.org

New Standard

BSR/IES LP-12-202x, Lighting Practice: IoT Connected Lighting (new standard)

Provide basic planning information for Connected Lighting Systems. The following topics and sections will be expanded upon to provide a common vocabulary for team members when developing their applications: Description of IoT and Connected Lighting, New Construction considerations, retrofit considerations, commercial and residential application considerations, wired and wireless systems, security, sequence of operations and commissioning, coordination considerations for specification and installation, explanation of applicable codes and standards.

Single copy price: \$25.00

Obtain an electronic copy from: pmcgillicuddy@ies.org

Send comments (with optional copy to psa@ansi.org) to: Patricia McGillicuddy; pmcgillicuddy@ies.org

NFPA (National Fire Protection Association)

One Batterymarch Park, Quincy, MA 02169 p: (617) 984-7246 w: www.nfpa.org

NFPA FIRE PROTECTION STANDARDS DOCUMENTATION

The National Fire Protection Association announces the availability of the NFPA First Draft Reports for concurrent review and comment by NFPA and ANSI. These First Draft Reports contain the disposition of public inputs that were received for standards in the Annual 2022 Revision Cycle.

The First Draft Report is located on the document's information page under the next edition tab. The document's specific URL, www.nfpa.org/doc#next (for example www.nfpa.org/101next), can easily access the document's information page. All Comments on standards in the Annual 2022 Revision Cycle must be submitted by June 3, 2021. The disposition of all comments received from the review of the First Draft Report will be published in the Second Draft Report, and will also be available on the document's information page under the next edition tab.

For more information on the rules and up-to-date information on deadlines for processing NFPA standards, check the NFPA website (<http://www.nfpa.org>) or contact Standards Administration at NFPA. Those who submit comments to NFPA are invited to copy ANSI's Board of Standards Review.

Revision

BSR/NFPA 2-202x, Hydrogen Technologies Code (revision of ANSI/NFPA 2-2019)

The purpose of this code shall be to provide fundamental safeguards for the generation, installation, storage, piping, use, and handling of hydrogen in compressed gas (GH2) form or cryogenic liquid (LH2) form. This code shall apply to the production, storage, transfer, and use of hydrogen in all occupancies.

Obtain an electronic copy from: www.nfpa.org/2Next

Send comments (with optional copy to psa@ansi.org) to: www.nfpa.org/2Next

Comment Deadline: May 24, 2021

NFPA (National Fire Protection Association)

One Batterymarch Park, Quincy, MA 02269-9101 p: (617) 984-7248 w: www.nfpa.org

NFPA FIRE PROTECTION STANDARDS DOCUMENTATION

The National Fire Protection Association announces the availability of the NFPA Second Draft Report for concurrent review and comment by NFPA and ANSI. These Second Draft Reports contain the disposition of public comment(s) that were received for standards in the ERRS Grp 1 Revision Cycle (available for review on the next edition tab for each standard). All Notices of Intent to Make A Motion on the ERRS Grp 1 Revision Cycle Second Draft Report must be received by the following date: **April 26, 2021**.

For more information on the rules and deadlines for NFPA standards in cycle, please check the NFPA website (www.nfpa.org) or contact Standards Administration at NFPA. Those who submit comments to NFPA's online submission system on the ERRS Grp 1 Revision Cycle Standards are invited to copy ANSI's Board of Standards Review.

Revision

BSR/NFPA 2500-202x, Standards for Operations and Training for Technical Search and Rescue Incidents and Life Safety Rope and Equipment for Emergency Services (revision, redesignation and consolidation of ANSI/NFPA 1670-2018, ANSI/NFPA 1983-2017, ANSI/NFPA 1858-2018)

This standard provides minimum requirements for conducting operations at technical search and rescue incidents, for the design, performance, testing, and certification of life safety rope and equipment for emergency services, and for the selection, care, and maintenance of rope and associated equipment.

Obtain an electronic copy from: www.nfpa.org/2500Next

Send comments (with optional copy to psa@ansi.org) to: www.nfpa.org/2500Next

NSF (NSF International)

789 N. Dixboro Road, Ann Arbor, MI 48105-9723 p: (734) 827-5643 w: www.nsf.org

Revision

BSR/NSF 42-202x (i111r1), Drinking Water Treatment Units - Aesthetic Effects (revision of ANSI/NSF 42-2020)

The point-of-use (POU) and point-of-entry (POE) systems addressed by this Standard are designed to be used for the reduction of specific substances that may be present in drinking water (public or private) considered to be microbiologically safe and of known quality. Systems covered under this Standard are intended to address one or more of the following: reduce substances affecting the aesthetic quality of the water, add chemicals for scale control, or limit microbial growth in the system (bacteriostatic). Substances may be soluble or particulate in nature. It is recognized that a system may be effective in controlling one or more of these substances but is not required to control all. Systems with manufacturer claims that include components or functions covered under other NSF or NSF/ANSI Standards or Criteria shall conform to the applicable requirements in those standards). Filter systems covered by this Standard are not intended to be used with drinking water that is microbiologically unsafe or of unknown quality without adequate disinfection before or after the system. [NOTE — Systems that are compliant with NSF/ANSI 55 Class A or other standards that cover technologies to treat microbiologically unsafe water (e.g., US EPA Guide Standard and Protocol for Testing Microbiological Water Purifiers or NSF P231) are examples of demonstrating adequate disinfection before or after the system.]

Single copy price: Free

Obtain an electronic copy from: https://standards.nsf.org/apps/group_public/download.php/58429/42i111r1%20et%20a%20-%20TOC%20-%20JC%20Memo%20%26%20Ballot.pdf

Send comments (with optional copy to psa@ansi.org) to: mleslie@nsf.org

Comment Deadline: May 24, 2021

NSF (NSF International)

789 N. Dixboro Road, Ann Arbor, MI 48105-9723 p: (734) 827-5643 w: www.nsf.org

Revision

BSR/NSF 53-202x (i129r1), Drinking Water Treatment Units - Health Effects (revision of ANSI/NSF 53-2020)

It is the purpose of this Standard to establish minimum requirements for materials, design and construction, and performance of point-of-use and point-of-entry drinking water treatment systems that are designed to reduce specific health-related contaminants in public or private water supplies. Such systems include point-of-entry drinking water treatment systems used to treat all or part of the water at the inlet to a residential facility or a bottled water production facility, and includes the material and components used in these systems. This Standard also specifies the minimum product literature and labeling information that a manufacturer shall supply to authorized representatives and system owners, as well as the minimum service-related obligations that the manufacturer shall extend to system owners.

Single copy price: Free

Obtain an electronic copy from: https://standards.nsf.org/apps/group_public/download.php/58429/42i111r1%20et%20a%20-%20TOC%20-%20JC%20Memo%20%26%20Ballot.pdf

Send comments (with optional copy to psa@ansi.org) to: mleslie@nsf.org

UL (Underwriters Laboratories)

12 Laboratory Drive, P.O. Box 13995, Research Triangle Park, NC 27709-3995 p: (919) 549-1391 w: <https://ul.org/>

National Adoption

BSR/UL 62841-3-9-202X, Standard for Electric Motor-Operated Hand-Held Tools, Transportable Tools and Lawn and Garden Machinery - Safety - Part 3.9: Particular Requirements for Transportable Mitre Saws (national adoption with modifications of IEC 62841-3-9 Ed. 2)

Proposed adoption of the second edition of IEC 62841-3-9, Standard for Electric Motor-Operated Hand-Held Tools, Transportable Tools and Lawn and Garden Machinery - Safety - Part 3.9: Particular Requirements for Transportable Mitre Saws as the second edition of UL 62841-3-9.

Single copy price: Free

Obtain an electronic copy from: <https://csds.ul.com/Home/ProposalsDefault.aspx>

Order from: <http://www.shopulstandards.com>

Send comments (with optional copy to psa@ansi.org) to: Follow the instructions in the following website to enter comments into the CSDS Work Area: <https://csds.ul.com/Home/ProposalsDefault.aspx>

UL (Underwriters Laboratories)

12 Laboratory Drive, Research Triangle Park, NC 27709-3995 p: (919) 316-5147 w: <https://ul.org/>

Reaffirmation

BSR/UL 2021-2021 (R202x), Standard for Antenna - Discharge Units (reaffirmation of ANSI/UL 2021-2021)

(1) Reaffirmation and continuance of the seventh edition of the Standard for Antenna – Discharge Units, UL 452, as an standard.

Single copy price: Free

Obtain an electronic copy from: <https://csds.ul.com/Home/ProposalsDefault.aspx>

Order from: <http://www.shopulstandards.com>

Send comments (with optional copy to psa@ansi.org) to: Follow the instructions in the following website to enter comments into the CSDS Work Area: <https://csds.ul.com/Home/ProposalsDefault.aspx>

Comment Deadline: May 24, 2021

UL (Underwriters Laboratories)

47173 Benicia Street, Fremont, CA 94538 p: (510) 319-4271 w: <https://ul.org/>

Reaffirmation

BSR/UL 61131-2-2008 (R202x), Standard for Safety for Programmable Controllers - Part 2: Equipment Requirements and Tests (reaffirmation of ANSI/UL 61131-2-2008 (R2017))

The intent of this proposal is to reaffirm UL 61131-2 as an standard.

Single copy price: Free

Obtain an electronic copy from: <https://csds.ul.com/Home/ProposalsDefault.aspx>

Order from: <http://www.shopulstandards.com>

Send comments (with optional copy to psa@ansi.org) to: Follow the instructions in the following website to enter comments into the CSDS Work Area: <https://csds.ul.com/Home/ProposalsDefault.aspx>

UL (Underwriters Laboratories)

47173 Benicia Street, Fremont, CA 94538 p: (510) 319-4259 w: <https://ul.org/>

Revision

BSR/UL 343-202x, Standard for Safety for Pumps for Oil-Burning Appliances (revision of ANSI/UL 343-2013 (R2017))

The following topic is being proposed: (1) Addition of Biodiesel (B6-B20) Requirements for Pumps for Oil-Burning Appliances

Single copy price: Free

Obtain an electronic copy from: <https://csds.ul.com/Home/ProposalsDefault.aspx>

Order from: <http://www.shopulstandards.com>

Send comments (with optional copy to psa@ansi.org) to: Follow the instructions in the following website to enter comments into the CSDS Work Area: <https://csds.ul.com/Home/ProposalsDefault.aspx>

UL (Underwriters Laboratories)

47173 Benicia Street, Fremont, CA 94538 p: (510) 319-4269 w: <https://ul.org/>

Revision

BSR/UL 2075-202x, Standard for Safety for Gas and Vapor Detectors and Sensors (revision of ANSI/UL 2075-2017)

Document proposes revisions to clarify the scope of the standard and also proposes a new one-year sensor stability test for gas sensors.

Single copy price: Free

Obtain an electronic copy from: <https://csds.ul.com/Home/ProposalsDefault.aspx>

Order from: <http://www.shopulstandards.com>

Send comments (with optional copy to psa@ansi.org) to: Follow the instructions in the following website to enter comments into the CSDS Work Area: <https://csds.ul.com/Home/ProposalsDefault.aspx>

Comment Deadline: June 8, 2021

ANS (American Nuclear Society)

555 North Kensington Avenue, La Grange Park, IL 60526 p: (708) 579-8268 w: www.ans.org

New Standard

Reaffirmations and withdrawals available electronically may be accessed at: webstore.ansi.org

BSR/ANS 30.3-202x, Advanced Light-Water Reactor Risk-Informed Performance-Based Design Criteria and Methods (new standard)

This standard establishes requirements for using risk-informed, performance-based (RIPB) methods for advanced light water reactor (LWR) designs. RIPB methods are provided to ensure nuclear safety design practices are consistently applied to all new advanced LWR reactor technologies, specifically; high-level safety criteria selection, nuclear safety functions and margin, licensing-basis-event selection and acceptance criteria, equipment classification and categorization, defense-in-depth adequacy, and evaluating conformance with regulatory positions. The application of this standard to existing reactors is beyond the scope of this standard.

Single copy price: \$25.00

Obtain an electronic copy from: orders@ans.org

Order from: orders@ans.org

Send comments (with optional copy to psa@ansi.org) to: pschroeder@ans.org

CSA (CSA America Standards Inc.)

8501 E. Pleasant Valley Road, Cleveland, OH 44131 p: (216) 524-4990 w: www.csagroup.org

Addenda

Reaffirmations and withdrawals available electronically may be accessed at: webstore.ansi.org

BSR/NGV 4.6a-202x, Manually operated valves for natural gas dispensing systems (addenda to ANSI/CSA NGV 4.6a-202x)

This standards contains safety requirements for the material, design, manufacture, and testing of manually operated valves for high-pressure natural gas. These requirements do not apply to cylinder shut-off valves.

Single copy price: Free

Obtain an electronic copy from: david.zimmerman@csagroup.org

Send comments (with optional copy to psa@ansi.org) to: david.zimmerman@csagroup.org

CSA (CSA America Standards Inc.)

8501 E. Pleasant Valley Road, Cleveland, OH 44131 p: (216) 524-4990 w: www.csagroup.org

New Standard

Reaffirmations and withdrawals available electronically may be accessed at: webstore.ansi.org

BSR/CSA C22.2 No. 298-202x, High Voltage Couplers (new standard)

This Standard applies to locking-type, pin-and-sleeve type plugs, receptacles, power inlets, connectors, junction boxes and live-end covers, rated up to 1,200 amperes (for single- and multi-pole) and above 750 V to 35 kV volts ac, 50/60 Hz or up to 1,500 volts dc and which shall have one or more pilot contacts for multi-pole configuration and above 750 V to 1000 V ac or dc for single pole configuration. These devices are intended to provide portable power from branch circuits, or are for direct connection to the branch circuit in accordance with the Canadian Electrical Code, Part I, or National Electrical Code (NEC) using portable power cables with copper conductors, for use in either indoor or outdoor, nonhazardous locations. The products covered in this Standard are commonly, but not exclusively, used in the following applications: open pit mining, underground mining, tunneling, shore-to-ship power, portable power equipment, general industrial use, and drilling.

Single copy price: Free

Obtain an electronic copy from: david.zimmerman@csagroup.org

Send comments (with optional copy to psa@ansi.org) to: david.zimmerman@csagroup.org

Comment Deadline: June 8, 2021

ITI (INCITS) (InterNational Committee for Information Technology Standards)

700 K Street NW, Suite 600, Washington, DC 20001 p: (202) 737-8888 w: www.incits.org

Reaffirmation

Reaffirmations and withdrawals available electronically may be accessed at: webstore.ansi.org

INCITS 284-2011 [R202x], Information Technology - Identification Cards - Health Care Identification Cards (reaffirmation of INCITS 284-2011 [R2016])

Describes the parameters for identification cards for health care applications in the United States.

Single copy price: \$60.00

Obtain an electronic copy from: <http://webstore.ansi.org/>

Order from: <http://webstore.ansi.org/>

Send comments (with optional copy to psa@ansi.org) to: comments@standards.incits.org

ITI (INCITS) (InterNational Committee for Information Technology Standards)

700 K Street NW, Suite 600, Washington, DC 20001 p: (202) 737-8888 w: www.incits.org

Reaffirmation

Reaffirmations and withdrawals available electronically may be accessed at: webstore.ansi.org

INCITS 381-2009/AM 1:2011 [R202x], Information technology - Finger Image Based Data Interchange Format - Amendment 1 (reaffirmation of INCITS 381-2009/AM 1:2011 [R2016])

Amendment 1 to INCITS 381:2009.

Single copy price: \$60.00

Obtain an electronic copy from: <http://webstore.ansi.org/>

Order from: <http://webstore.ansi.org/>

Send comments (with optional copy to psa@ansi.org) to: comments@standards.incits.org

ITI (INCITS) (InterNational Committee for Information Technology Standards)

700 K Street NW, Suite 600, Washington, DC 20001 p: (202) 737-8888 w: www.incits.org

Reaffirmation

Reaffirmations and withdrawals available electronically may be accessed at: webstore.ansi.org

INCITS 409.4-2006 [R202x], Information technology - Biometric Performance Testing and Reporting - Part 4: Operational Testing Methodologies (reaffirmation of INCITS 409.4-2006 [R2016])

This standard is Part 4 (Operational Testing Methodologies) of the standard for Information Technology - Biometric Performance Testing and Reporting, INCITS 409. The objective of this standard is to establish requirements for operational performance-based biometric testing and reporting.

Single copy price: \$60.00

Obtain an electronic copy from: <http://webstore.ansi.org/>

Order from: <http://webstore.ansi.org/>

Send comments (with optional copy to psa@ansi.org) to: comments@standards.incits.org

ITI (INCITS) (InterNational Committee for Information Technology Standards)

700 K Street NW, Suite 600, Washington, DC 20001 p: (202) 737-8888 w: www.incits.org

Reaffirmation

Reaffirmations and withdrawals available electronically may be accessed at: webstore.ansi.org

INCITS 409.5-2011 [R202x], Information Technology -Biometric Performance Testing and Reporting - Part 5: Framework for Testing and Evaluation of Biometric System(s) for Access Control (reaffirmation of INCITS 409.5-2011 [R2016])

This standard is concerned solely with the scientific 'technical performance testing' of biometric system(s) and subsystem(s) to be used for access control.

Single copy price: \$60.00

Obtain an electronic copy from: <http://webstore.ansi.org/>

Order from: <http://webstore.ansi.org/>

Send comments (with optional copy to psa@ansi.org) to: comments@standards.incits.org

Comment Deadline: June 8, 2021

ITI (INCITS) (InterNational Committee for Information Technology Standards)

700 K Street NW, Suite 600, Washington, DC 20001 p: (202) 737-8888 w: www.incits.org

Reaffirmation

Reaffirmations and withdrawals available electronically may be accessed at: webstore.ansi.org

INCITS 458-2011 [R202x], Information technology - SCSI Object-Based Storage Device Commands-2 (OSD-2) (reaffirmation of INCITS 458-2011 [R2016])

Defines the command set extensions to control operation of Object-Based Storage devices. The clause(s) of this standard pertaining to the SCSI Object-Based Storage Device class, implemented in conjunction with the applicable clauses of the ISO/IEC 14776-453, SCSI Primary Commands - 4 (SPC-4), specify the standard command set for SCSI Object-Based Storage devices.

Single copy price: \$60.00

Obtain an electronic copy from: <http://webstore.ansi.org/>

Order from: <http://webstore.ansi.org/>

Send comments (with optional copy to psa@ansi.org) to: comments@standards.incits.org

ITI (INCITS) (InterNational Committee for Information Technology Standards)

700 K Street NW, Suite 600, Washington, DC 20001 p: (202) 737-8888 w: www.incits.org

Reaffirmation

Reaffirmations and withdrawals available electronically may be accessed at: webstore.ansi.org

INCITS 459-2011 [R202x], Information Technology - Requirements for the Implementation and Interoperability of Role Based Access Control (reaffirmation of INCITS 459-2011 [R2016])

Specifies the implementation of RBAC systems. It describes the packaging of features through the selection of functional components and feature options within a component, beginning with a core set of RBAC features that shall be included in all packages.

Single copy price: \$60.00

Obtain an electronic copy from: <http://webstore.ansi.org/>

Order from: <http://webstore.ansi.org/>

Send comments (with optional copy to psa@ansi.org) to: comments@standards.incits.org

ITI (INCITS) (InterNational Committee for Information Technology Standards)

700 K Street NW, Suite 600, Washington, DC 20001 p: (202) 737-8888 w: www.incits.org

Reaffirmation

Reaffirmations and withdrawals available electronically may be accessed at: webstore.ansi.org

INCITS 467-2011 [R202x], Information technology - SCSI Stream Commands - 3 (SSC-3) (reaffirmation of INCITS 467-2011 [R2016])

Defines the command set extensions to facilitate operation of the sequential-access device type. This standard, implemented in conjunction with the requirements of the SCSI Architecture Model - 4 standard and the applicable clauses of the SCSI Primary Commands - 4 standard, fully specify the standard command set for the sequential-access device type.

Single copy price: \$60.00

Obtain an electronic copy from: <http://webstore.ansi.org/>

Order from: <http://webstore.ansi.org/>

Send comments (with optional copy to psa@ansi.org) to: comments@standards.incits.org

Comment Deadline: June 8, 2021

ITI (INCITS) (InterNational Committee for Information Technology Standards)

700 K Street NW, Suite 600, Washington, DC 20001 p: (202) 737-8888 w: www.incits.org

Reaffirmation

Reaffirmations and withdrawals available electronically may be accessed at: webstore.ansi.org

INCITS 472-2011 [R202x], Information Technology - Automation/Drive Interface - Transport Protocol - 2 (ADT-2) (reaffirmation of INCITS 472-2011 [R2016])

Defines the protocol requirements of the Automation/Drive Interface - Transport Protocol to allow conforming ADI SCSI devices to inter-operate.

Single copy price: \$60.00

Obtain an electronic copy from: <http://webstore.ansi.org/>

Order from: <http://webstore.ansi.org/>

Send comments (with optional copy to psa@ansi.org) to: comments@standards.incits.org

ITI (INCITS) (InterNational Committee for Information Technology Standards)

700 K Street NW, Suite 600, Washington, DC 20001 p: (202) 737-8888 w: www.incits.org

Reaffirmation

Reaffirmations and withdrawals available electronically may be accessed at: webstore.ansi.org

INCITS 473-2011 [R202x], Information Technology - Conformance Testing Methodology Standard for Patron Formats Conforming to INCITS 398-2008, Information Technology - Common Biometric Exchange Formats Framework (CBEFF) (reaffirmation of INCITS 473-2011 [R2016])

Specifies the concepts test types and a conformance testing methodology to test conformance of CBEFF Biometric Information Records BIR claiming to be conformant to patron formats A the BioAPI BIR or the NIST ITL Type 99 data record specified in INCITS 398 2008 annexes as well as the LDS patron format for applications other than MRTD and other ICAO applications.

Single copy price: \$60.00

Obtain an electronic copy from: <http://webstore.ansi.org/>

Order from: <http://webstore.ansi.org/>

Send comments (with optional copy to psa@ansi.org) to: comments@standards.incits.org

ITI (INCITS) (InterNational Committee for Information Technology Standards)

700 K Street NW, Suite 600, Washington, DC 20001 p: (202) 737-8888 w: www.incits.org

Reaffirmation

Reaffirmations and withdrawals available electronically may be accessed at: webstore.ansi.org

INCITS 474-2011 [R202x], Information Technology - Biometric Application Programming Interface - Java (BioAPI Java) (reaffirmation of INCITS 474-2011 [R2016])

Specifies an interface of a BioAPI Java framework and BioAPI Java BSP and BioAPI BFP that will mirror the corresponding components specified in ISO/IEC 19784-1.

Single copy price: \$60.00

Obtain an electronic copy from: <http://webstore.ansi.org/>

Order from: <http://webstore.ansi.org/>

Send comments (with optional copy to psa@ansi.org) to: comments@standards.incits.org

Comment Deadline: June 8, 2021

ITI (INCITS) (InterNational Committee for Information Technology Standards)

700 K Street NW, Suite 600, Washington, DC 20001 p: (202) 737-8888 w: www.incits.org

Reaffirmation

Reaffirmations and withdrawals available electronically may be accessed at: webstore.ansi.org

INCITS 478-2011 [R202x], Information technology - Serial Attached SCSI - 2.1 (SAS-2.1) (reaffirmation of INCITS 478-2011 [R2016])

The SCSI family of standards provides for many different transport protocols that define the rules for exchanging information between different SCSI devices. This standard specifies the functional requirements for the Serial Attached SCSI (SAS) physical interconnect, which is compatible with the Serial ATA physical interconnect. The SAS Protocol Layer (SPL) standard documents the SAS protocol layer corresponding to the Serial Attached SCSI - 2.1 (SAS-2.1) and beyond, defining the rules for exchanging information between SCSI devices using a serial interconnect. Other SCSI transport protocol standards define the rules for exchanging information between SCSI devices using other interconnects.

Single copy price: \$60.00

Obtain an electronic copy from: <http://webstore.ansi.org/>

Order from: <http://webstore.ansi.org/>

Send comments (with optional copy to psa@ansi.org) to: comments@standards.incits.org

ITI (INCITS) (InterNational Committee for Information Technology Standards)

700 K Street NW, Suite 600, Washington, DC 20001 p: (202) 737-8888 w: www.incits.org

Reaffirmation

Reaffirmations and withdrawals available electronically may be accessed at: webstore.ansi.org

INCITS 479-2011/AM 1-2016 [R202x], Information Technology - Fibre Channel - Physical Interface - 5/Amendment 1 (FC-PI-5/AM1) (reaffirmation of INCITS 479-2011/AM 1-2016)

This amendment updates INCITS 479-2011, FC-PI-5, to allow for forward error correction on 16GFC EL variants.

Single copy price: \$60.00

Obtain an electronic copy from: <http://webstore.ansi.org/>

Order from: <http://webstore.ansi.org/>

Send comments (with optional copy to psa@ansi.org) to: comments@standards.incits.org

ITI (INCITS) (InterNational Committee for Information Technology Standards)

700 K Street NW, Suite 600, Washington, DC 20001 p: (202) 737-8888 w: www.incits.org

Reaffirmation

Reaffirmations and withdrawals available electronically may be accessed at: webstore.ansi.org

INCITS 481-2011 [R202x], Information technology - Fibre Channel Protocol for SCSI - 4 (FCP-4) (reaffirmation of INCITS 481-2011 [R2016])

FCP-4 defines the fourth generation Fibre Channel Protocol to be used to transport SCSI commands over the T11 Fibre Channel interface.

Single copy price: \$60.00

Obtain an electronic copy from: <http://webstore.ansi.org/>

Order from: <http://webstore.ansi.org/>

Send comments (with optional copy to psa@ansi.org) to: comments@standards.incits.org

Comment Deadline: June 8, 2021

ITI (INCITS) (InterNational Committee for Information Technology Standards)

700 K Street NW, Suite 600, Washington, DC 20001 p: (202) 737-8888 w: www.incits.org

Reaffirmation

Reaffirmations and withdrawals available electronically may be accessed at: webstore.ansi.org

INCITS 488-2016 [R202x], Information Technology - Fibre Channel - Framing and Signaling - 4 (FC-FS-4) (reaffirmation of INCITS 488-2016)

This standard describes the framing and signaling interface of a high-performance serial link for support of FC-4s associated with upper level protocols (e.g., SCSI, IP, SBCCS, VI).

Single copy price: \$60.00

Obtain an electronic copy from: <http://webstore.ansi.org/>

Order from: <http://webstore.ansi.org/>

Send comments (with optional copy to psa@ansi.org) to: comments@standards.incits.org

ITI (INCITS) (InterNational Committee for Information Technology Standards)

700 K Street NW, Suite 600, Washington, DC 20001 p: (202) 737-8888 w: www.incits.org

Reaffirmation

Reaffirmations and withdrawals available electronically may be accessed at: webstore.ansi.org

INCITS 501-2016 [R202x], Information technology - Security Features for SCSI Commands (SFSC) (reaffirmation of INCITS 501-2016)

Defines security features for use by all SCSI devices. This standard defines the security model that is basic to every device model and the parameter data that may apply to any device model.

Single copy price: \$60.00

Obtain an electronic copy from: <http://webstore.ansi.org/>

Order from: <http://webstore.ansi.org/>

Send comments (with optional copy to psa@ansi.org) to: comments@standards.incits.org

ITI (INCITS) (InterNational Committee for Information Technology Standards)

700 K Street NW, Suite 600, Washington, DC 20001 p: (202) 737-8888 w: www.incits.org

Reaffirmation

Reaffirmations and withdrawals available electronically may be accessed at: webstore.ansi.org

INCITS 504-3-2016 [R202x], Information Technology - Generic Identity Command Set - Part 3: GICS Platform Testing Requirements (reaffirmation of INCITS 504-3-2016)

Testing in part 3 is limited to definition for what testing is required and does not provide technical guidelines on the methodology to be used during the testing and validation of applicable components. Focuses on platform conformance testing of Part 1 and Part 2, and focuses on what needs to be tested to enforce full functionality and interoperability. In particular, instances of brute force, exhaustive, or open-ended negative testing are not specified in the requirements in this standard. There are no test requirements for negative testing to determine abnormal behavior with the exception of interrogating access control rules and elicitation of error codes where possible and appropriate.

Single copy price: \$60.00

Obtain an electronic copy from: <http://webstore.ansi.org/>

Order from: <http://webstore.ansi.org/>

Send comments (with optional copy to psa@ansi.org) to: comments@standards.incits.org

Comment Deadline: June 8, 2021

ITI (INCITS) (InterNational Committee for Information Technology Standards)

700 K Street NW, Suite 600, Washington, DC 20001 p: (202) 737-8888 w: www.incits.org

Reaffirmation

Reaffirmations and withdrawals available electronically may be accessed at: webstore.ansi.org

INCITS 504-1-2013/AM1-2016 [R202x], Information technology - Generic Identity Command Set - Part 1: Card Application Command Set - Amendment 1 (reaffirmation of INCITS 504-1-2013/AM1-2016)

This amendment aligns Part 1 of INCITS 504-1 to the newly released ISO/IEC 7816-4 standard; simplifies the Opacity protocols and fixes bugs; modifies SCP03 protocol to describe creation of share secret Z; and makes editorial changes, adds clarifications, and fixes errors.

Single copy price: \$60.00

Obtain an electronic copy from: <http://webstore.ansi.org/>

Order from: <http://webstore.ansi.org/>

Send comments (with optional copy to psa@ansi.org) to: comments@standards.incits.org

ITI (INCITS) (InterNational Committee for Information Technology Standards)

700 K Street NW, Suite 600, Washington, DC 20001 p: (202) 737-8888 w: www.incits.org

Reaffirmation

Reaffirmations and withdrawals available electronically may be accessed at: webstore.ansi.org

INCITS 504-2-2013/AM 1-2016 [R202x], Information Technology - Generic Identity Command Set - Part 2: Card Administrative Command Set - Amendment 1 (reaffirmation of INCITS 504-2-2013/AM 1-2016)

This amendment to INCITS 504-1 adds On Card Comparison capability (OCC); adds Over The Air (OTA) capability; and makes editorial changes, adds clarifications, and fixes errors

Single copy price: \$60.00

Obtain an electronic copy from: <http://webstore.ansi.org/>

Order from: <http://webstore.ansi.org/>

Send comments (with optional copy to psa@ansi.org) to: comments@standards.incits.org

ITI (INCITS) (InterNational Committee for Information Technology Standards)

700 K Street NW, Suite 600, Washington, DC 20001 p: (202) 737-8888 w: www.incits.org

Reaffirmation

Reaffirmations and withdrawals available electronically may be accessed at: webstore.ansi.org

INCITS 507-2016 [R202x], Information technology - PCIe® architecture Queuing Interface - 2(PQI-2) (reaffirmation of INCITS 507-2016)

The SCSI family of standards provides for different transport protocols that define the methods for exchanging information between SCSI devices. This standard defines the transport methods for exchanging information between SCSI devices using a PCI Express interconnect. This standard defines a queuing layer, used by SOP. Other SCSI transport protocol standards define the methods for exchanging information between SCSI devices using other interconnects.

Single copy price: \$60.00

Obtain an electronic copy from: <http://webstore.ansi.org/>

Order from: <http://webstore.ansi.org/>

Send comments (with optional copy to psa@ansi.org) to: comments@standards.incits.org

Comment Deadline: June 8, 2021

ITI (INCITS) (InterNational Committee for Information Technology Standards)

700 K Street NW, Suite 600, Washington, DC 20001 p: (202) 737-8888 w: www.incits.org

Reaffirmation

Reaffirmations and withdrawals available electronically may be accessed at: webstore.ansi.org

INCITS 511-2016 [R202x], Information Technology - Fibre Channel - Switch Fabric - 6 (FC-SW-6) (reaffirmation of INCITS 511-2016)

FC-SW-6 describes the operation and interaction of Fibre Channel Switches.

Single copy price: \$60.00

Obtain an electronic copy from: <http://webstore.ansi.org/>

Order from: <http://webstore.ansi.org/>

Send comments (with optional copy to psa@ansi.org) to: comments@standards.incits.org

ITI (INCITS) (InterNational Committee for Information Technology Standards)

700 K Street NW, Suite 600, Washington, DC 20001 p: (202) 737-8888 w: www.incits.org

Reaffirmation

Reaffirmations and withdrawals available electronically may be accessed at: webstore.ansi.org

INCITS 515-2016 [R202x], Information technology - SCSI Architecture Model - 5 (SAM-5) (reaffirmation of INCITS 515-2016)

The set of Small Computer System Interface (SCSI) standards consists of this standard and the SCSI implementation standards described in 4.2 of this standard. This standard defines a reference model that specifies common behaviors for SCSI devices, and an abstract structure that is generic to all SCSI I/O system implementations.

Single copy price: \$60.00

Obtain an electronic copy from: <http://webstore.ansi.org/>

Order from: <http://webstore.ansi.org/>

Send comments (with optional copy to psa@ansi.org) to: comments@standards.incits.org

ITI (INCITS) (InterNational Committee for Information Technology Standards)

700 K Street NW, Suite 600, Washington, DC 20001 p: (202) 737-8888 w: www.incits.org

Reaffirmation

Reaffirmations and withdrawals available electronically may be accessed at: webstore.ansi.org

INCITS 524-2016 [R202x], Information Technology - AT Attachment 8 - ATA/ATAPI Parallel Transport (ATA8-APT) (reaffirmation of INCITS 524-2016)

Specifies the mandatory and optional operating features of a parallel bus transport for ATA commands described in the AT Attachment 8 - Command Set (ATA8-ACS) standard. It provides a common attachment interface for systems manufacturers, system integrators, software suppliers, and suppliers of intelligent storage devices. This document specifies the connectors, cables, electrical, and logic parameters for the interconnect between a device and the host, and the transport protocols for transporting commands, data, status, and other relevant communications across a parallel bus interface.

Single copy price: \$60.00

Obtain an electronic copy from: <http://webstore.ansi.org/>

Order from: <http://webstore.ansi.org/>

Send comments (with optional copy to psa@ansi.org) to: comments@standards.incits.org

Comment Deadline: June 8, 2021

ITI (INCITS) (InterNational Committee for Information Technology Standards)

700 K Street NW, Suite 600, Washington, DC 20001 p: (202) 737-8888 w: www.incits.org

Reaffirmation

Reaffirmations and withdrawals available electronically may be accessed at: webstore.ansi.org

INCITS 533-2016 [R202x], Information Technology - Fibre Channel - Physical Interface - 6P (FC-PI-6P) (reaffirmation of INCITS 533-2016)

Describes the physical interface portions of high-performance electrical and optical link variants that support the higher level Fibre Channel protocols including FC-FS-4 (reference [22]). FC-PI-6P includes the parallel four-lane variants 128GFC-SW4 and 128GFC-PSM4 and the CWDM four-wavelength variant 128GFC-CWMD4.

Single copy price: \$60.00

Obtain an electronic copy from: <http://webstore.ansi.org/>

Order from: <http://webstore.ansi.org/>

Send comments (with optional copy to psa@ansi.org) to: comments@standards.incits.org

ITI (INCITS) (InterNational Committee for Information Technology Standards)

700 K Street NW, Suite 600, Washington, DC 20001 p: (202) 737-8888 w: www.incits.org

Reaffirmation

Reaffirmations and withdrawals available electronically may be accessed at: webstore.ansi.org

INCITS 536-2016 [R202x], Information technology - Zoned Block Commands (ZBC) (reaffirmation of INCITS 536-2016)

Defines the model and command set extensions to facilitate operation of zoned block devices.

Single copy price: \$60.00

Obtain an electronic copy from: <http://webstore.ansi.org/>

Order from: <http://webstore.ansi.org/>

Send comments (with optional copy to psa@ansi.org) to: comments@standards.incits.org

ITI (INCITS) (InterNational Committee for Information Technology Standards)

700 K Street NW, Suite 600, Washington, DC 20001 p: (202) 737-8888 w: www.incits.org

Reaffirmation

Reaffirmations and withdrawals available electronically may be accessed at: webstore.ansi.org

INCITS 537-2016 [R202x], Information technology - Zoned Device ATA Command Set (ZAC) (reaffirmation of INCITS 537-2016)

The set of AT Attachment standards consists of this standard and the ATA implementation standards described in AT Attachment - 8 ATA/ATAPI Architecture Model (ATA8-AAM). This standard specifies the command set that host systems use to access storage devices that implement the Host Aware Zones feature set (see 4.3) or the Host Managed Zones feature set (see 4.4). This standard provides a common command set for systems manufacturers, system integrators, software suppliers, and suppliers of storage devices that provide one of the zones' feature sets.

Single copy price: \$60.00

Obtain an electronic copy from: <http://webstore.ansi.org/>

Order from: <http://webstore.ansi.org/>

Send comments (with optional copy to psa@ansi.org) to: comments@standards.incits.org

Comment Deadline: June 8, 2021

ITI (INCITS) (InterNational Committee for Information Technology Standards)

700 K Street NW, Suite 600, Washington, DC 20001 p: (202) 737-8888 w: www.incits.org

Reaffirmation

Reaffirmations and withdrawals available electronically may be accessed at: webstore.ansi.org

INCITS 539-2016 [R202x], Information Technology - Management of Security Credentials (reaffirmation of INCITS 539-2016)

The Simple Identity Management Profile (see clause 5) is a component profile that provides the ability to manage local accounts on a system and to represent the local system's view of a principal that is authenticated through a third-party authentication service. The Simple Identity Management Profile does not specify CIM-based mechanisms for performing the authentication of credentials.

Single copy price: \$60.00

Obtain an electronic copy from: <http://webstore.ansi.org/>

Order from: <http://webstore.ansi.org/>

Send comments (with optional copy to psa@ansi.org) to: comments@standards.incits.org

ITI (INCITS) (InterNational Committee for Information Technology Standards)

700 K Street NW, Suite 600, Washington, DC 20001 p: (202) 737-8888 w: www.incits.org

Reaffirmation

Reaffirmations and withdrawals available electronically may be accessed at: webstore.ansi.org

INCITS/ISO 19105:2000 [R202x], Geographic information - Conformance and testing (reaffirm a national adoption INCITS/ISO 19105:2000 [R2016])

Specifies the framework, concepts, and methodology for testing and criteria to be achieved to claim conformance to the family of ISO geographic information standards. It provides a framework for specifying abstract test suites (ATS) and for defining the procedures to be followed during conformance testing. Conformance may be claimed for data or software products or services or by specifications including any profile or functional standard.

Single copy price: \$69.00

Obtain an electronic copy from: <http://webstore.ansi.org/>

Order from: <http://webstore.ansi.org/>

Send comments (with optional copy to psa@ansi.org) to: comments@standards.incits.org

ITI (INCITS) (InterNational Committee for Information Technology Standards)

700 K Street NW, Suite 600, Washington, DC 20001 p: (202) 737-8888 w: www.incits.org

Reaffirmation

Reaffirmations and withdrawals available electronically may be accessed at: webstore.ansi.org

INCITS/ISO 19123:2005 [R202x], Geographic Information - Schema for Coverage Geometry and Functions (reaffirm a national adoption INCITS/ISO 19123:2005 [R2016])

Defines a conceptual schema for the spatial characteristics of coverages. Coverages support mapping from a spatial, temporal, or spatiotemporal domain to feature attribute values where feature attribute types are common to all geographic positions within the domain.

Single copy price: \$60.00

Obtain an electronic copy from: <http://webstore.ansi.org/>

Order from: <http://webstore.ansi.org/>

Send comments (with optional copy to psa@ansi.org) to: comments@standards.incits.org

Comment Deadline: June 8, 2021

ITI (INCITS) (InterNational Committee for Information Technology Standards)

700 K Street NW, Suite 600, Washington, DC 20001 p: (202) 737-8888 w: www.incits.org

Reaffirmation

Reaffirmations and withdrawals available electronically may be accessed at: webstore.ansi.org

INCITS/ISO 19133:2005 [R202x], Geographic Information - Location Based Services - Tracking and Navigation (reaffirm a national adoption INCITS/ISO 19133:2005 [R2016])

Describes the data types, and operations associated with those types, for the implementation of tracking and navigation services. It is designed to specify web services that can be made available to wireless devices through web-resident proxy applications, but is not restricted to that environment.

Single copy price: \$116.00

Obtain an electronic copy from: <http://webstore.ansi.org/>

Order from: <http://webstore.ansi.org/>

Send comments (with optional copy to psa@ansi.org) to: comments@standards.incits.org

ITI (INCITS) (InterNational Committee for Information Technology Standards)

700 K Street NW, Suite 600, Washington, DC 20001 p: (202) 737-8888 w: www.incits.org

Reaffirmation

Reaffirmations and withdrawals available electronically may be accessed at: webstore.ansi.org

INCITS/ISO 19142:2010 [R202x], Geographic Information - Web Feature Service (reaffirm a national adoption INCITS/ISO 19142:2010 [R2016])

Specifies the behavior of a web feature service that provides transactions on and access to geographic features in a manner independent of the underlying data store. It specifies discovery operations, query operations, locking operations, transaction operations, and operations to manage stored parameterized query expressions.

Single copy price: \$116.00

Obtain an electronic copy from: <http://webstore.ansi.org/>

Order from: <http://webstore.ansi.org/>

Send comments (with optional copy to psa@ansi.org) to: comments@standards.incits.org

ITI (INCITS) (InterNational Committee for Information Technology Standards)

700 K Street NW, Suite 600, Washington, DC 20001 p: (202) 737-8888 w: www.incits.org

Reaffirmation

Reaffirmations and withdrawals available electronically may be accessed at: webstore.ansi.org

INCITS/ISO 19143:2010 [R202x], Geographic Information - Filter Encoding (reaffirm a national adoption INCITS/ISO 19143:2010 [R2016])

Describes an XML and KVP encoding of a system-neutral syntax for expressing projections, selection, and sorting clauses, collectively called a "query expression".

Single copy price: \$116.00

Obtain an electronic copy from: <http://webstore.ansi.org/>

Order from: <http://webstore.ansi.org/>

Send comments (with optional copy to psa@ansi.org) to: comments@standards.incits.org

Comment Deadline: June 8, 2021

ITI (INCITS) (InterNational Committee for Information Technology Standards)

700 K Street NW, Suite 600, Washington, DC 20001 p: (202) 737-8888 w: www.incits.org

Reaffirmation

Reaffirmations and withdrawals available electronically may be accessed at: webstore.ansi.org

INCITS/ISO 9542:1988/AM 1:1999 [R202x], Information processing systems - Telecommunications and information exchange between systems - End System to Intermediate System Routing Exchange Protocol for Use in Conjunction with the Protocol for Providing the Connectionless-Mode Network Service - Amendment 1: Addition of group composition information (reaffirm a national adoption INCITS/ISO 9542:1988/AM 1:1999 [R2016])

Specifies (a) procedures for transmission of multicast announcement, multicast address mapping, and group composition information between Network entities residing in End Systems and Network entities residing in Intermediate Systems; (b) the encoding of the protocol data units used for multicast announcement, multicast address mapping, and group composition information.

Single copy price: \$60.00

Obtain an electronic copy from: <http://webstore.ansi.org/>

Order from: <http://webstore.ansi.org/>

Send comments (with optional copy to psa@ansi.org) to: comments@standards.incits.org

ITI (INCITS) (InterNational Committee for Information Technology Standards)

700 K Street NW, Suite 600, Washington, DC 20001 p: (202) 737-8888 w: www.incits.org

Reaffirmation

Reaffirmations and withdrawals available electronically may be accessed at: webstore.ansi.org

INCITS/ISO/IEC 7811-8:2014 [R202x], Identification cards - Recording technique - Part 8: Magnetic stripe - Coercivity of 51,7 kA/m (650 Oe) (reaffirm a national adoption INCITS/ISO/IEC 7811-8:2014 [2016])

Defines the characteristics for identification cards as defined in Clause 4 of this part of ISO/IEC 7811, and the use of such cards for international interchange. This part of ISO/IEC 7811 specifies requirements for a 51,7 kA/m (650 Oe) magnetic stripe (including any protective overlay) on an identification card. The encoding technique and coded character sets are not defined; however, the specifications of ISO/IEC 7811-2 may be used. It takes into consideration both human and machine aspects and states minimum requirements.

Single copy price: \$60.00

Obtain an electronic copy from: <http://webstore.ansi.org/>

Order from: <http://webstore.ansi.org/>

Send comments (with optional copy to psa@ansi.org) to: comments@standards.incits.org

ITI (INCITS) (InterNational Committee for Information Technology Standards)

700 K Street NW, Suite 600, Washington, DC 20001 p: (202) 737-8888 w: www.incits.org

Reaffirmation

Reaffirmations and withdrawals available electronically may be accessed at: webstore.ansi.org

INCITS/ISO/IEC 7811-9:2015 [R202x], Identification cards - Recording technique - Part 9: Tactile identifier mark (reaffirm a national adoption INCITS/ISO/IEC 7811-9:2015 [2016])

Specifies the physical characteristics of a tactile identifier mark used by visually impaired card holders to distinguish their cards. It defines the area on the card for the tactile identifier mark (TIM) and the layout of Braille-style embossed dots arranged in patterns to enable easy tactile recognition.

Single copy price: \$60.00

Obtain an electronic copy from: <http://webstore.ansi.org/>

Order from: <http://webstore.ansi.org/>

Send comments (with optional copy to psa@ansi.org) to: comments@standards.incits.org

Comment Deadline: June 8, 2021

ITI (INCITS) (InterNational Committee for Information Technology Standards)

700 K Street NW, Suite 600, Washington, DC 20001 p: (202) 737-8888 w: www.incits.org

Reaffirmation

Reaffirmations and withdrawals available electronically may be accessed at: webstore.ansi.org

INCITS/ISO/IEC 10118-2:2010 [R202x], Information technology - Security techniques - Hash-functions - Part 2: Hash-functions using an n-bit block cipher (reaffirm a national adoption INCITS/ISO/IEC 10118-2:2010 [R2016])

Specifies hash-functions which make use of an n-bit block cipher algorithm. They are therefore suitable for an environment in which such an algorithm is already implemented.

Single copy price: \$81.00

Obtain an electronic copy from: <http://webstore.ansi.org/>

Order from: <http://webstore.ansi.org/>

Send comments (with optional copy to psa@ansi.org) to: comments@standards.incits.org

ITI (INCITS) (InterNational Committee for Information Technology Standards)

700 K Street NW, Suite 600, Washington, DC 20001 p: (202) 737-8888 w: www.incits.org

Reaffirmation

Reaffirmations and withdrawals available electronically may be accessed at: webstore.ansi.org

INCITS/ISO/IEC 10373-2:2015 [R202x], Identification cards - Test methods - Part 2: Cards with magnetic stripes (reaffirm a national adoption INCITS/ISO/IEC 10373-2:2015 [2016])

Defines test methods for characteristics of identification cards according to the definition given in ISO/IEC 7810. Each test method is cross-referenced to one or more base standards, for example ISO/IEC 7810, or one or more of the supplementary standards that define the information storage technologies employed in identification card applications. Defines test methods which are specific to magnetic stripe technology.

Single copy price: \$78.00

Obtain an electronic copy from: <http://webstore.ansi.org/>

Order from: <http://webstore.ansi.org/>

Send comments (with optional copy to psa@ansi.org) to: comments@standards.incits.org

ITI (INCITS) (InterNational Committee for Information Technology Standards)

700 K Street NW, Suite 600, Washington, DC 20001 p: (202) 737-8888 w: www.incits.org

Reaffirmation

Reaffirmations and withdrawals available electronically may be accessed at: webstore.ansi.org

INCITS/ISO/IEC 11179-5:2015 [R202x], Information technology - Metadata registries (MDR) - Part 5: Naming principles (reaffirm a national adoption INCITS/ISO/IEC 11179-5:2015 [2016])

Provides instruction for naming of the following items, as defined in ISO/IEC 11179-3: concept, data element concept, conceptual domain, data element, and value domain. Describes naming in a metadata registries (MDR); includes principles and rules by which naming conventions can be developed; and provides examples of naming conventions.

Single copy price: \$62.00

Obtain an electronic copy from: <http://webstore.ansi.org/>

Order from: <http://webstore.ansi.org/>

Send comments (with optional copy to psa@ansi.org) to: comments@standards.incits.org

Comment Deadline: June 8, 2021

ITI (INCITS) (InterNational Committee for Information Technology Standards)

700 K Street NW, Suite 600, Washington, DC 20001 p: (202) 737-8888 w: www.incits.org

Reaffirmation

Reaffirmations and withdrawals available electronically may be accessed at: webstore.ansi.org

INCITS/ISO/IEC 11694-3:2015 [R202x], Identification cards - Optical memory cards - Linear recording method - Part 3: Optical properties and characteristics (reaffirm a national adoption INCITS/ISO/IEC 11694-3:2015 [2016])

Specifies the optical properties and characteristics of optical memory cards using the linear recording method.

Single copy price: \$60.00

Obtain an electronic copy from: <http://webstore.ansi.org/>

Order from: <http://webstore.ansi.org/>

Send comments (with optional copy to psa@ansi.org) to: comments@standards.incits.org

ITI (INCITS) (InterNational Committee for Information Technology Standards)

700 K Street NW, Suite 600, Washington, DC 20001 p: (202) 737-8888 w: www.incits.org

Reaffirmation

Reaffirmations and withdrawals available electronically may be accessed at: webstore.ansi.org

INCITS/ISO/IEC 11694-4:2008 [R202x], Identification cards - Optical memory cards - Linear recording method - Part 4: Logical data structures (reaffirm a national adoption INCITS/ISO/IEC 11694-4:2008 [2016])

Defines the logical data structures for optical memory cards necessary to allow compatibility and interchange between systems using the linear recording method.

Single copy price: \$60.00

Obtain an electronic copy from: <http://webstore.ansi.org/>

Order from: <http://webstore.ansi.org/>

Send comments (with optional copy to psa@ansi.org) to: comments@standards.incits.org

ITI (INCITS) (InterNational Committee for Information Technology Standards)

700 K Street NW, Suite 600, Washington, DC 20001 p: (202) 737-8888 w: www.incits.org

Reaffirmation

Reaffirmations and withdrawals available electronically may be accessed at: webstore.ansi.org

INCITS/ISO/IEC 11694-5:2014 [R202x], Identification cards - Optical memory cards - Linear recording method - Part 5: Data format for information interchange for applications using ISO/IEC 11694-4 (reaffirm a national adoption INCITS/ISO/IEC 11694-5:2014 [2016])

Defines the data format for optical memory cards necessary to allow compatibility and interchange between systems using the linear recording method.

Single copy price: \$60.00

Obtain an electronic copy from: <http://webstore.ansi.org/>

Order from: <http://webstore.ansi.org/>

Send comments (with optional copy to psa@ansi.org) to: comments@standards.incits.org

ITI (INCITS) (InterNational Committee for Information Technology Standards)

700 K Street NW, Suite 600, Washington, DC 20001 p: (202) 737-8888 w: www.incits.org

Reaffirmation

Reaffirmations and withdrawals available electronically may be accessed at: webstore.ansi.org

INCITS/ISO/IEC 11694-6:2014 [R202x], Identification cards - Optical memory cards - Linear recording method - Part 6: Use of biometrics on an optical memory card (reaffirm a national adoption INCITS/ISO/IEC 11694-6:2014 [2016])

Describes the use of biometric data on optical memory cards using the logical data structure described in ISO/IEC 11694-5.

Single copy price: \$60.00

Obtain an electronic copy from: <http://webstore.ansi.org/>

Order from: <http://webstore.ansi.org/>

Send comments (with optional copy to psa@ansi.org) to: comments@standards.incits.org

Comment Deadline: June 8, 2021

ITI (INCITS) (InterNational Committee for Information Technology Standards)

700 K Street NW, Suite 600, Washington, DC 20001 p: (202) 737-8888 w: www.incits.org

Reaffirmation

Reaffirmations and withdrawals available electronically may be accessed at: webstore.ansi.org

INCITS/ISO/IEC 11695-1:2015 [R202x], Identification cards - Optical memory cards - Holographic recording method - Part 1: Physical characteristics (reaffirm a national adoption INCITS/ISO/IEC 11695-1:2015 [2016])

Defines the physical characteristics of optical memory cards using the holographic recording method.

Single copy price: \$60.00

Obtain an electronic copy from: <http://webstore.ansi.org/>

Order from: <http://webstore.ansi.org/>

Send comments (with optional copy to psa@ansi.org) to: comments@standards.incits.org

ITI (INCITS) (InterNational Committee for Information Technology Standards)

700 K Street NW, Suite 600, Washington, DC 20001 p: (202) 737-8888 w: www.incits.org

Reaffirmation

Reaffirmations and withdrawals available electronically may be accessed at: webstore.ansi.org

INCITS/ISO/IEC 11695-2:2015 [R202x], Identification cards - Optical memory cards - Holographic recording method - Part 2: Dimensions and location of accessible optical area (reaffirm a national adoption INCITS/ISO/IEC 11695-2:2015 [2016])

Defines the dimensions and location of the accessible optical area of optical memory cards using the holographic recording method.

Single copy price: \$60.00

Obtain an electronic copy from: <http://webstore.ansi.org/>

Order from: <http://webstore.ansi.org/>

Send comments (with optional copy to psa@ansi.org) to: comments@standards.incits.org

ITI (INCITS) (InterNational Committee for Information Technology Standards)

700 K Street NW, Suite 600, Washington, DC 20001 p: (202) 737-8888 w: www.incits.org

Reaffirmation

Reaffirmations and withdrawals available electronically may be accessed at: webstore.ansi.org

INCITS/ISO/IEC 13818-4:2004/AM3:2009 [R202x], Information technology - Generic coding of moving pictures and associated audio information - Part 4: Conformance testing - Amendment 3: Level for 108050p/60p conformance testing (reaffirm a national adoption INCITS/ISO/IEC 13818-4:2004/AM3:2009 [R2016])

Amendment 3 to ISO/IEC 13818-4:2004.

Single copy price: \$60.00

Obtain an electronic copy from: <http://webstore.ansi.org/>

Order from: <http://webstore.ansi.org/>

Send comments (with optional copy to psa@ansi.org) to: comments@standards.incits.org

ITI (INCITS) (InterNational Committee for Information Technology Standards)

700 K Street NW, Suite 600, Washington, DC 20001 p: (202) 737-8888 w: www.incits.org

Reaffirmation

Reaffirmations and withdrawals available electronically may be accessed at: webstore.ansi.org

INCITS/ISO/IEC 13818-6:1998/AM 1:2000 [R202x], Information technology - Generic coding of moving pictures & associated audio info - Part 6: Extensions for DSM-CC - Amendment 1: Additions to support data broadcasting (reaffirm a national adoption INCITS/ISO/IEC 13818-6:1998/AM 1:2000 [R2016])

Amendment 1 to ISO/IEC 13818-6:1998.

Single copy price: \$60.00

Obtain an electronic copy from: <http://webstore.ansi.org/>

Order from: <http://webstore.ansi.org/>

Send comments (with optional copy to psa@ansi.org) to: comments@standards.incits.org

Comment Deadline: June 8, 2021

ITI (INCITS) (InterNational Committee for Information Technology Standards)

700 K Street NW, Suite 600, Washington, DC 20001 p: (202) 737-8888 w: www.incits.org

Reaffirmation

Reaffirmations and withdrawals available electronically may be accessed at: webstore.ansi.org

INCITS/ISO/IEC 14495-1:1999 [R202x], Information technology - Lossless and near-lossless compression of continuous-tone still images: Baseline (reaffirm a national adoption INCITS/ISO/IEC 14495-1:1999 [R2016])

Defines a set of lossless (bit-preserving) and nearly lossless (where the error for each reconstructed sample is bounded by a pre-defined value) compression methods for coding continuous-tone, gray-scale, or color digital still images. This standard specifies a process for converting source image data to compressed image data; specifies processes for converting compressed image data to reconstructed image data; specifies coded representations for compressed image data; and provides guidance on how to implement these processes in practice.

Single copy price: \$75.00

Obtain an electronic copy from: <http://webstore.ansi.org/>

Order from: <http://webstore.ansi.org/>

Send comments (with optional copy to psa@ansi.org) to: comments@standards.incits.org

ITI (INCITS) (InterNational Committee for Information Technology Standards)

700 K Street NW, Suite 600, Washington, DC 20001 p: (202) 737-8888 w: www.incits.org

Reaffirmation

Reaffirmations and withdrawals available electronically may be accessed at: webstore.ansi.org

INCITS/ISO/IEC 14496-4:2004 [R202x], Information technology - Coding of audio-visual objects - Part 4: Conformance testing (reaffirm a national adoption INCITS/ISO/IEC 14496-4:2004 [R2016])

Specifies how tests can be designed to verify whether bitstreams and decoders meet requirements specified in parts 1, 2, and 3 of ISO/IEC 14496 and, for part 6 of ISO/IEC 14496, it specifies how tests can be designed for bitstream delivery over various delivery technologies in an interoperable transparent manner to parts 1, 2, and 3. In this part of ISO/IEC 14496, encoders are not addressed specifically. An encoder may be said to be an ISO/IEC 14496 encoder if it generates bitstreams compliant with the syntactic and semantic bitstream requirements specified in parts 1, 2, and 3 of ISO/IEC 14496.

Single copy price: \$116.00

Obtain an electronic copy from: <http://webstore.ansi.org/>

Order from: <http://webstore.ansi.org/>

Send comments (with optional copy to psa@ansi.org) to: comments@standards.incits.org

ITI (INCITS) (InterNational Committee for Information Technology Standards)

700 K Street NW, Suite 600, Washington, DC 20001 p: (202) 737-8888 w: www.incits.org

Reaffirmation

Reaffirmations and withdrawals available electronically may be accessed at: webstore.ansi.org

INCITS/ISO/IEC 14496-6:2000 [R202x], Information technology - Coding of audio-visual objects - Part 6: Delivery Multimedia Integration Framework (DMIF) (reaffirm a national adoption INCITS/ISO/IEC 14496-6:2000 [R2016])

Specifies the Delivery Layer of ISO/IEC 14496, which allows applications to transparently access and view multimedia streams whether the source of the streams is located on an interactive remote end-system, the streams are available on broadcast media or they are on storage media.

Single copy price: \$116.00

Obtain an electronic copy from: <http://webstore.ansi.org/>

Order from: <http://webstore.ansi.org/>

Send comments (with optional copy to psa@ansi.org) to: comments@standards.incits.org

Comment Deadline: June 8, 2021

ITI (INCITS) (InterNational Committee for Information Technology Standards)

700 K Street NW, Suite 600, Washington, DC 20001 p: (202) 737-8888 w: www.incits.org

Reaffirmation

Reaffirmations and withdrawals available electronically may be accessed at: webstore.ansi.org

INCITS/ISO/IEC 14496-20:2008AM1:2009 [R202x], Information technology - Coding of audio-visual objects - Part 20: Lightweight Application Scene Representation (LASER) and Simple Aggregation Format (SAF) - Amendment 1: Extensions to support SVGT1.2 (reaffirm a national adoption INCITS/ISO/IEC 14496-20:2008AM1:2009 [R2016])

Amendment 1 to ISO/IEC 14496-20:2008.

Single copy price: \$60.00

Obtain an electronic copy from: <http://webstore.ansi.org/>

Order from: <http://webstore.ansi.org/>

Send comments (with optional copy to psa@ansi.org) to: comments@standards.incits.org

ITI (INCITS) (InterNational Committee for Information Technology Standards)

700 K Street NW, Suite 600, Washington, DC 20001 p: (202) 737-8888 w: www.incits.org

Reaffirmation

Reaffirmations and withdrawals available electronically may be accessed at: webstore.ansi.org

INCITS/ISO/IEC 14496-4:2004/AM 30:2009 [R202x], Information technology - Coding of audio-visual objects - Part 4: Conformance testing - Amendment 30: Conformance testing for new profiles for professional applications (reaffirm a national adoption INCITS/ISO/IEC 14496-4:2004/AM 30:2009 [R2016])

Amendment 30 to ISO/IEC 14496-4:2004.

Single copy price: \$60.00

Obtain an electronic copy from: <http://webstore.ansi.org/>

Order from: <http://webstore.ansi.org/>

Send comments (with optional copy to psa@ansi.org) to: comments@standards.incits.org

ITI (INCITS) (InterNational Committee for Information Technology Standards)

700 K Street NW, Suite 600, Washington, DC 20001 p: (202) 737-8888 w: www.incits.org

Reaffirmation

Reaffirmations and withdrawals available electronically may be accessed at: webstore.ansi.org

INCITS/ISO/IEC 14496-4:2004/AM 31:2009 [R202x], Information technology - Coding of audio-visual objects - Part 4: Conformance testing - Amendment 31: Conformance testing for SVC profiles (reaffirm a national adoption INCITS/ISO/IEC 14496-4:2004/AM 31:2009 [R2016])

Amendment 31 to ISO/IEC 14496-4:2004.

Single copy price: \$93.00

Obtain an electronic copy from: <http://webstore.ansi.org/>

Order from: <http://webstore.ansi.org/>

Send comments (with optional copy to psa@ansi.org) to: comments@standards.incits.org

ITI (INCITS) (InterNational Committee for Information Technology Standards)

700 K Street NW, Suite 600, Washington, DC 20001 p: (202) 737-8888 w: www.incits.org

Reaffirmation

Reaffirmations and withdrawals available electronically may be accessed at: webstore.ansi.org

INCITS/ISO/IEC 14496-4:2004/AM 35:2009 [R202x], Information technology - Coding of audio-visual objects - Part 4: Conformance testing - Amendment 35: Simple studio profile levels 5 and 6 conformance testing (reaffirm a national adoption INCITS/ISO/IEC 14496-4:2004/AM 35:2009 [R2016])

Amendment 35 to ISO/IEC 14496-4:2004.

Single copy price: \$60.00

Obtain an electronic copy from: <http://webstore.ansi.org/>

Order from: <http://webstore.ansi.org/>

Send comments (with optional copy to psa@ansi.org) to: comments@standards.incits.org

Comment Deadline: June 8, 2021

ITI (INCITS) (InterNational Committee for Information Technology Standards)

700 K Street NW, Suite 600, Washington, DC 20001 p: (202) 737-8888 w: www.incits.org

Reaffirmation

Reaffirmations and withdrawals available electronically may be accessed at: webstore.ansi.org

INCITS/ISO/IEC 14496-5:2001/AM 14:2009 [R202x], Information technology - Coding of audio-visual objects - Part 5: Reference software - Amendment 14: Open Font Format reference software (reaffirm a national adoption INCITS/ISO/IEC 14496-5:2001/AM 14:2009 [R2016])

Amendment 14 to ISO/IEC 14496-5:2001.

Single copy price: \$60.00

Obtain an electronic copy from: <http://webstore.ansi.org/>

Order from: <http://webstore.ansi.org/>

Send comments (with optional copy to psa@ansi.org) to: comments@standards.incits.org

ITI (INCITS) (InterNational Committee for Information Technology Standards)

700 K Street NW, Suite 600, Washington, DC 20001 p: (202) 737-8888 w: www.incits.org

Reaffirmation

Reaffirmations and withdrawals available electronically may be accessed at: webstore.ansi.org

INCITS/ISO/IEC 14496-5:2001/AM 19:2009 [R202x], Information technology - Coding of audio-visual objects - Part 5: Reference software - Amendment 19: Reference software for Scalable Video Coding (reaffirm a national adoption INCITS/ISO/IEC 14496-5:2001/AM 19:2009 [R2016])

Amendment 19 to ISO/IEC 14496-5:2001.

Single copy price: \$60.00

Obtain an electronic copy from: <http://webstore.ansi.org/>

Order from: <http://webstore.ansi.org/>

Send comments (with optional copy to psa@ansi.org) to: comments@standards.incits.org

ITI (INCITS) (InterNational Committee for Information Technology Standards)

700 K Street NW, Suite 600, Washington, DC 20001 p: (202) 737-8888 w: www.incits.org

Reaffirmation

Reaffirmations and withdrawals available electronically may be accessed at: webstore.ansi.org

INCITS/ISO/IEC 14496-5:2001/AM 20:2009 [R202x], Information technology - Coding of audio-visual objects - Part 5: Reference software - Amendment 20: MPEG-1 and -2 on MPEG-4 reference software and BSAC Extensions (reaffirm a national adoption INCITS/ISO/IEC 14496-5:2001/AM 20:2009 [R2016])

Amendment 20 to ISO/IEC 14496-5:2001.

Single copy price: \$60.00

Obtain an electronic copy from: <http://webstore.ansi.org/>

Order from: <http://webstore.ansi.org/>

Send comments (with optional copy to psa@ansi.org) to: comments@standards.incits.org

ITI (INCITS) (InterNational Committee for Information Technology Standards)

700 K Street NW, Suite 600, Washington, DC 20001 p: (202) 737-8888 w: www.incits.org

Reaffirmation

Reaffirmations and withdrawals available electronically may be accessed at: webstore.ansi.org

INCITS/ISO/IEC 14496-5:2001/AM 21:2009 [R202x], Information technology - Coding of audio-visual objects - Part 5: Reference software - Amendment 21: Frame-based Animated Mesh Compression reference software (reaffirm a national adoption INCITS/ISO/IEC 14496-5:2001/AM 21:2009 [R2016])

Amendment 21 to ISO/IEC 14496-5:2001.

Single copy price: \$60.00

Obtain an electronic copy from: <http://webstore.ansi.org/>

Order from: <http://webstore.ansi.org/>

Send comments (with optional copy to psa@ansi.org) to: comments@standards.incits.org

Comment Deadline: June 8, 2021

ITI (INCITS) (InterNational Committee for Information Technology Standards)

700 K Street NW, Suite 600, Washington, DC 20001 p: (202) 737-8888 w: www.incits.org

Reaffirmation

Reaffirmations and withdrawals available electronically may be accessed at: webstore.ansi.org

INCITS/ISO/IEC 15444-8:2007/AM 1:2008 [R202x], Information technology - JPEG 2000 image coding system: Secure JPEG 2000 - Amendment 1: File format security (reaffirm a national adoption INCITS/ISO/IEC 15444-8:2007/AM 1:2008 [R2016])

Specifies the framework, concepts, and methodology for securing JPEG 2000 codestreams. Defines a normative codestream syntax containing information for interpreting secure image data; a normative process for registering JPSEC tools with a registration authority delivering a unique identifier; informative examples of JPSEC tools in typical use cases; informative guidelines on how to implement security services and related metadata. It does not describe specific secure imaging applications or limit secure imaging to specific techniques, but creates a framework that enables future extensions as secure imaging techniques evolve.

Single copy price: \$81.00

Obtain an electronic copy from: <http://webstore.ansi.org/>

Order from: <http://webstore.ansi.org/>

Send comments (with optional copy to psa@ansi.org) to: comments@standards.incits.org

ITI (INCITS) (InterNational Committee for Information Technology Standards)

700 K Street NW, Suite 600, Washington, DC 20001 p: (202) 737-8888 w: www.incits.org

Reaffirmation

Reaffirmations and withdrawals available electronically may be accessed at: webstore.ansi.org

INCITS/ISO/IEC 15457-1:2008 [R202x], Identification cards - Thin flexible cards - Part 1: Physical characteristics (reaffirm a national adoption INCITS/ISO/IEC 15457-1:2008 [R2016])

Thin flexible cards (TFC), the subject of ISO/IEC 15457, are used to automate the controls for access to goods or services such as mass transit, highway toll systems, car parks, vouchers, stored value, etc. For these applications, data can be written and/or read by machines using various recording techniques such as magnetic stripe, optical character recognition (OCR), bar code, contactless, etc. This standard specifies the physical characteristics of thin flexible cards at two points in the card life cycle: at the point of loading into the card issuing equipment or at the point of issue to the public.

Single copy price: \$60.00

Obtain an electronic copy from: <http://webstore.ansi.org/>

Order from: <http://webstore.ansi.org/>

Send comments (with optional copy to psa@ansi.org) to: comments@standards.incits.org

ITI (INCITS) (InterNational Committee for Information Technology Standards)

700 K Street NW, Suite 600, Washington, DC 20001 p: (202) 737-8888 w: www.incits.org

Reaffirmation

Reaffirmations and withdrawals available electronically may be accessed at: webstore.ansi.org

INCITS/ISO/IEC 15457-3:2008 [R202x], Identification cards - Thin flexible cards - Part 3: Test methods (reaffirm a national adoption INCITS/ISO/IEC 15457-3:2008 [R2016])

Thin flexible cards are used to automate the controls for access to goods or services such as mass transit, highway toll systems, car parks, vouchers, stored value, etc. For these applications, data can be written and/or read by machines using various recording techniques such as magnetic stripe, optical character recognition (OCR), bar code, etc. Specifies the test methods and procedures required to carry out measurements of the magnetic stripe and encoding characteristics of thin flexible cards.

Single copy price: \$60.00

Obtain an electronic copy from: <http://webstore.ansi.org/>

Order from: <http://webstore.ansi.org/>

Send comments (with optional copy to psa@ansi.org) to: comments@standards.incits.org

Comment Deadline: June 8, 2021

ITI (INCITS) (InterNational Committee for Information Technology Standards)

700 K Street NW, Suite 600, Washington, DC 20001 p: (202) 737-8888 w: www.incits.org

Reaffirmation

Reaffirmations and withdrawals available electronically may be accessed at: webstore.ansi.org

INCITS/ISO/IEC 15938-3:2002/AM 3:2009 [R202x], Information technology - Multimedia content description interface - Part 3: Visual - Amendment 3: Image Signature Tools (reaffirm a national adoption INCITS/ISO/IEC 15938-3:2002/AM 3:2009 [R2016])

Amendment 3 to ISO/IEC 15938-3:2002.

Single copy price: \$60.00

Obtain an electronic copy from: <http://webstore.ansi.org/>

Order from: <http://webstore.ansi.org/>

Send comments (with optional copy to psa@ansi.org) to: comments@standards.incits.org

ITI (INCITS) (InterNational Committee for Information Technology Standards)

700 K Street NW, Suite 600, Washington, DC 20001 p: (202) 737-8888 w: www.incits.org

Reaffirmation

Reaffirmations and withdrawals available electronically may be accessed at: webstore.ansi.org

INCITS/ISO/IEC 19775-2:2015 [R202x], Information Technology - Computer Graphics, Image Processing and Environmental Data Representation - Extensible 3D (X3D) - Part 2: Scene Access Interface (SAI) (reaffirm a national adoption INCITS/ISO/IEC 19775-2:2015 [2016])

Specifies a standard set of services that are made available by a browser so that an author can access the scene graph while it is running. Such access is designed to support inspection and modification of the scene graph.

Single copy price: \$60.00

Obtain an electronic copy from: <http://webstore.ansi.org/>

Order from: <http://webstore.ansi.org/>

Send comments (with optional copy to psa@ansi.org) to: comments@standards.incits.org

ITI (INCITS) (InterNational Committee for Information Technology Standards)

700 K Street NW, Suite 600, Washington, DC 20001 p: (202) 737-8888 w: www.incits.org

Reaffirmation

Reaffirmations and withdrawals available electronically may be accessed at: webstore.ansi.org

INCITS/ISO/IEC 19784-4:2011 [R202x], Information technology - Biometric application programming interface - Part 4: Biometric sensor function provider interface (reaffirm a national adoption INCITS/ISO/IEC 19784-4:2011 [R2016])

Specifies a biometric sensor interface for a Biometric Service Provider (BSP, see ISO/IEC 19784-1). The interface supports a BSP wishing to provide the BioAPI Service Provider Interface (SPI) functions, whilst removing device handling activity from the BSP. Provides an interface that can be used by all types of biometric sensor, including inter alia image streaming sensors (infrared, face, iris, finger, etc.), voice streaming sensors, and digital tablets providing dynamic signature data.

Single copy price: \$60.00

Obtain an electronic copy from: <http://webstore.ansi.org/>

Order from: <http://webstore.ansi.org/>

Send comments (with optional copy to psa@ansi.org) to: comments@standards.incits.org

Comment Deadline: June 8, 2021

ITI (INCITS) (InterNational Committee for Information Technology Standards)

700 K Street NW, Suite 600, Washington, DC 20001 p: (202) 737-8888 w: www.incits.org

Reaffirmation

Reaffirmations and withdrawals available electronically may be accessed at: webstore.ansi.org

INCITS/ISO/IEC 19795-5:2011 [R202x], Information technology - Biometric performance testing and reporting - Part 5: Access control scenario and grading scheme (reaffirm a national adoption INCITS/ISO/IEC 19795-5:2011 [R2016])

Specifies a framework for testing and a grading scheme for reporting the performance of a biometric system suitable for use in access control applications. It also allows for specifying application performance requirements in terms of the required performance of the biometric component of the access control system. It specifies the environment in which and the means by which testing will be performed and how the results will be reported. The grading scheme takes a conservative approach, using statistical analysis and confidence intervals to support the claim that the device performance is at least as good as the graded performance indicates. Addresses conventional access control circumstances, and unusual or extreme circumstances are not within its scope.

Single copy price: \$60.00

Obtain an electronic copy from: <http://webstore.ansi.org/>

Order from: <http://webstore.ansi.org/>

Send comments (with optional copy to psa@ansi.org) to: comments@standards.incits.org

ITI (INCITS) (InterNational Committee for Information Technology Standards)

700 K Street NW, Suite 600, Washington, DC 20001 p: (202) 737-8888 w: www.incits.org

Reaffirmation

Reaffirmations and withdrawals available electronically may be accessed at: webstore.ansi.org

INCITS/ISO/IEC 19795-7:2011 [R202x], Information technology - Biometric performance testing and reporting - Part 7: Testing of on-card biometric comparison algorithms (reaffirm a national adoption INCITS/ISO/IEC 19795-7:2011 [R2016])

Establishes a mechanism for measuring the core algorithmic capabilities of biometric comparison algorithms running on ISO/IEC 7816 integrated circuit cards. Specifically, the standard instantiates a mechanism for on-card biometric comparison testing; standardizes procedures for the measurement of the accuracy of on-card biometric comparison implementations running on object-based, test-specific sample cards; standardizes procedures for the measurement of durations of the various operations; and gives examples for matching ISO/IEC 19794-2:2005 compact card minutiae templates.

Single copy price: \$60.00

Obtain an electronic copy from: <http://webstore.ansi.org/>

Order from: <http://webstore.ansi.org/>

Send comments (with optional copy to psa@ansi.org) to: comments@standards.incits.org

ITI (INCITS) (InterNational Committee for Information Technology Standards)

700 K Street NW, Suite 600, Washington, DC 20001 p: (202) 737-8888 w: www.incits.org

Reaffirmation

Reaffirmations and withdrawals available electronically may be accessed at: webstore.ansi.org

INCITS/ISO/IEC 21000-8:2008/AM 1:2009 [R202x], Information technology - Multimedia framework (MPEG-21) - Part 8: Reference software - Amendment 1: Extract reference software (reaffirm a national adoption INCITS/ISO/IEC 21000-8:2008/AM 1:2009 [R2016])

Amendment 1 to ISO/IEC 21000-8:2008.

Single copy price: \$60.00

Obtain an electronic copy from: <http://webstore.ansi.org/>

Order from: <http://webstore.ansi.org/>

Send comments (with optional copy to psa@ansi.org) to: comments@standards.incits.org

Comment Deadline: June 8, 2021

ITI (INCITS) (InterNational Committee for Information Technology Standards)

700 K Street NW, Suite 600, Washington, DC 20001 p: (202) 737-8888 w: www.incits.org

Reaffirmation

Reaffirmations and withdrawals available electronically may be accessed at: webstore.ansi.org

INCITS/ISO/IEC 23000-4:2009 [R202x], Information technology - Multimedia application format (MPEG-A) - Part 4: Musical slide show application format (reaffirm a national adoption INCITS/ISO/IEC 23000-4:2009 [R2016])

Specifies signaling of content governance and protection of musical slide show application format based on MPEG-21, Part 4: Intellectual Property Management and Protection (IPMP) Components Base Profile and MPEG-21.

Single copy price: \$105.00

Obtain an electronic copy from: <http://webstore.ansi.org/>

Order from: <http://webstore.ansi.org/>

Send comments (with optional copy to psa@ansi.org) to: comments@standards.incits.org

ITI (INCITS) (InterNational Committee for Information Technology Standards)

700 K Street NW, Suite 600, Washington, DC 20001 p: (202) 737-8888 w: www.incits.org

Reaffirmation

Reaffirmations and withdrawals available electronically may be accessed at: webstore.ansi.org

INCITS/ISO/IEC 23000-3:2007/AM1:2009 [R202x], Information technology - Multimedia application format (MPEG-A) - Part 3: MPEG photo player application format - Amendment 1: Reference software for photo player MAF (reaffirm a national adoption INCITS/ISO/IEC 23000-3:2007/AM1:2009 [R2016])

Amendment 1 to ISO/IEC 23000-3:2007.

Single copy price: \$60.00

Obtain an electronic copy from: <http://webstore.ansi.org/>

Order from: <http://webstore.ansi.org/>

Send comments (with optional copy to psa@ansi.org) to: comments@standards.incits.org

ITI (INCITS) (InterNational Committee for Information Technology Standards)

700 K Street NW, Suite 600, Washington, DC 20001 p: (202) 737-8888 w: www.incits.org

Reaffirmation

Reaffirmations and withdrawals available electronically may be accessed at: webstore.ansi.org

INCITS/ISO/IEC 23000-4:2009/AM 1:2009 [R202x], Information technology - Multimedia application format (MPEG-A) - Part 4: Musical slide show application format - Amendment 1: Conformance and reference software for musical slide show application format (reaffirm a national adoption INCITS/ISO/IEC 23000-4:2009/AM 1:2009 [R2016])

Amendment 1 to ISO/IEC 23000-4:2009.

Single copy price: \$60.00

Obtain an electronic copy from: <http://webstore.ansi.org/>

Order from: <http://webstore.ansi.org/>

Send comments (with optional copy to psa@ansi.org) to: comments@standards.incits.org

ITI (INCITS) (InterNational Committee for Information Technology Standards)

700 K Street NW, Suite 600, Washington, DC 20001 p: (202) 737-8888 w: www.incits.org

Reaffirmation

Reaffirmations and withdrawals available electronically may be accessed at: webstore.ansi.org

INCITS/ISO/IEC 23000-7:2008/AM 1:2009 [R202x], Information technology - Multimedia application format (MPEG-A) - Part 7: Open access application format - Amendment 1: Conformance and reference software for open access application format (reaffirm a national adoption INCITS/ISO/IEC 23000-7:2008/AM 1:2009 [R2016])

Amendment 1 to ISO/IEC 23000-7:2008.

Single copy price: \$60.00

Obtain an electronic copy from: <http://webstore.ansi.org/>

Order from: <http://webstore.ansi.org/>

Send comments (with optional copy to psa@ansi.org) to: comments@standards.incits.org

Comment Deadline: June 8, 2021

ITI (INCITS) (InterNational Committee for Information Technology Standards)

700 K Street NW, Suite 600, Washington, DC 20001 p: (202) 737-8888 w: www.incits.org

Reaffirmation

Reaffirmations and withdrawals available electronically may be accessed at: webstore.ansi.org

INCITS/ISO/IEC 23004-8:2009 [R202x], Information technology - Multimedia Middleware - Part 8: Reference software (reaffirm a national adoption INCITS/ISO/IEC 23004-8:2009 [R2016])

This standard explains the organization of the reference software for ISO/IEC 23004, Parts 1 to 7 (Multimedia Middleware). The electronic attachment to ISO/IEC 23004-8:2009 provides the source code of the actual software.

Single copy price: \$81.00

Obtain an electronic copy from: <http://webstore.ansi.org/>

Order from: <http://webstore.ansi.org/>

Send comments (with optional copy to psa@ansi.org) to: comments@standards.incits.org

ITI (INCITS) (InterNational Committee for Information Technology Standards)

700 K Street NW, Suite 600, Washington, DC 20001 p: (202) 737-8888 w: www.incits.org

Reaffirmation

Reaffirmations and withdrawals available electronically may be accessed at: webstore.ansi.org

INCITS/ISO/IEC 24709-3:2011 [R202x], Information technology - Conformance testing for the biometric application programming interface (BioAPI) - Part 3: Test assertions for BioAPI frameworks (reaffirm a national adoption INCITS/ISO/IEC 24709-3:2011 [R2016])

Defines a number of test assertions written in the assertion language specified in ISO/IEC 24709-1:2007. Specifies all the test assertions that are to be executed for conformance testing of BioAPI frameworks claiming conformance to ISO/IEC 19784-1 (BioAPI 2.0). Test assertions specified in this part of ISO/IEC 24709 are not claimed to be exhaustive (see also ISO/IEC 24709-1:2007, Clause 6). Implementations of BioAPI 2.0 that are tested according to the methodology specified in ISO/IEC 24709-1:2007 and with test assertions specified in this part can (only) claim conformance to those aspects of ISO/IEC 19784-1 that are covered by these test assertions.

Single copy price: \$60.00

Obtain an electronic copy from: <http://webstore.ansi.org/>

Order from: <http://webstore.ansi.org/>

Send comments (with optional copy to psa@ansi.org) to: comments@standards.incits.org

ITI (INCITS) (InterNational Committee for Information Technology Standards)

700 K Street NW, Suite 600, Washington, DC 20001 p: (202) 737-8888 w: www.incits.org

Reaffirmation

Reaffirmations and withdrawals available electronically may be accessed at: webstore.ansi.org

INCITS/ISO/IEC 24775-1:2014 [R202x], Information technology - Storage management - Part 1: Overview (reaffirm a national adoption INCITS/ISO/IEC 24775-1:2014 [2016])

Defines an interface for the secure, extensible, and interoperable management of a distributed and heterogeneous storage system. This interface uses an object-oriented, XML-based, messaging-based protocol designed to support the specific requirements of managing devices and subsystems in this storage environment. Using this protocol, this part of ISO/IEC 24775 describes the information available to a WBEM Client from an Information Technology - Storage Management compliant CIM WBEM Server.

Single copy price: \$69.00

Obtain an electronic copy from: <http://webstore.ansi.org/>

Order from: <http://webstore.ansi.org/>

Send comments (with optional copy to psa@ansi.org) to: comments@standards.incits.org

Comment Deadline: June 8, 2021

ITI (INCITS) (InterNational Committee for Information Technology Standards)

700 K Street NW, Suite 600, Washington, DC 20001 p: (202) 737-8888 w: www.incits.org

Reaffirmation

Reaffirmations and withdrawals available electronically may be accessed at: webstore.ansi.org

INCITS/ISO/IEC 24775-2:2014 [R202x], Information technology - Storage management - Part 2: Common Architecture (reaffirm a national adoption INCITS/ISO/IEC 24775-2:2014 [2016])

Defines the core architecture and protocols in SMI-S. The components of SMI-S architecture include:
Transport - communicating management information between constituents of the management system;
Health and fault management - detecting failures through monitoring the state of storage components;
General information about the object model;
Names - how SMI-S uses names to allow applications to correlate across SMI-S and to other standards;
Standard messages - how exceptions are presented to client applications;
Service discovery - techniques clients use to discover SMI-S services; and
Installation and upgrade - recommendations for implementations.

Single copy price: \$116.00

Obtain an electronic copy from: <http://webstore.ansi.org/>

Order from: <http://webstore.ansi.org/>

Send comments (with optional copy to psa@ansi.org) to: comments@standards.incits.org

ITI (INCITS) (InterNational Committee for Information Technology Standards)

700 K Street NW, Suite 600, Washington, DC 20001 p: (202) 737-8888 w: www.incits.org

Reaffirmation

Reaffirmations and withdrawals available electronically may be accessed at: webstore.ansi.org

INCITS/ISO/IEC 24775-3:2014 [R202x], Information technology - Storage management - Part 3: Common Profiles (reaffirm a national adoption INCITS/ISO/IEC 24775-3:2014 [2016])

Defines profiles that are supported by profiles defined in the other parts of the ISO/IEC 24775 series. The first few clauses provide background material that helps explain the purpose and profiles and recipes (a subset of a profile). Common port profiles are grouped together since they serve as transport-specific variations of a common model. The port profiles are followed by other common profiles.

Single copy price: \$116.00

Obtain an electronic copy from: <http://webstore.ansi.org/>

Order from: <http://webstore.ansi.org/>

Send comments (with optional copy to psa@ansi.org) to: comments@standards.incits.org

ITI (INCITS) (InterNational Committee for Information Technology Standards)

700 K Street NW, Suite 600, Washington, DC 20001 p: (202) 737-8888 w: www.incits.org

Reaffirmation

Reaffirmations and withdrawals available electronically may be accessed at: webstore.ansi.org

INCITS/ISO/IEC 24775-4:2014 [R202x], Information technology - Storage management - Part 4: Block Devices (reaffirm a national adoption INCITS/ISO/IEC 24775-4:2014 [2016])

Defines an interface for the secure, extensible, and interoperable management of a distributed and heterogeneous storage system. This interface uses an object-oriented, XML-based, messaging-based protocol designed to support the specific requirements of managing devices and subsystems in this storage environment. Using this protocol, this International Standard describes the information available to a WBEM Client from an Information technology - Storage management compliant CIM WBEM Server.

Single copy price: \$116.00

Obtain an electronic copy from: <http://webstore.ansi.org/>

Order from: <http://webstore.ansi.org/>

Send comments (with optional copy to psa@ansi.org) to: comments@standards.incits.org

Comment Deadline: June 8, 2021

ITI (INCITS) (InterNational Committee for Information Technology Standards)

700 K Street NW, Suite 600, Washington, DC 20001 p: (202) 737-8888 w: www.incits.org

Reaffirmation

Reaffirmations and withdrawals available electronically may be accessed at: webstore.ansi.org

INCITS/ISO/IEC 24775-5:2014 [R202x], Information technology - Storage management - Part 5: File systems (reaffirm a national adoption INCITS/ISO/IEC 24775-5:2014 [2016])

Defines management profiles for Autonomous (top-level) profiles for programs and devices whose central function is providing support and access to file data. In addition, it provides documentation of component profiles (or subprofiles) that deal with file systems and management interface functions that may be used by other autonomous profiles not included in this part of the standard.

Single copy price: \$116.00

Obtain an electronic copy from: <http://webstore.ansi.org/>

Order from: <http://webstore.ansi.org/>

Send comments (with optional copy to psa@ansi.org) to: comments@standards.incits.org

ITI (INCITS) (InterNational Committee for Information Technology Standards)

700 K Street NW, Suite 600, Washington, DC 20001 p: (202) 737-8888 w: www.incits.org

Reaffirmation

Reaffirmations and withdrawals available electronically may be accessed at: webstore.ansi.org

INCITS/ISO/IEC 24775-6:2014 [R202x], Information technology - Storage management - Part 6: Fabric (reaffirm a national adoption INCITS/ISO/IEC 24775-6:2014 [2016])

Defines management profiles for Autonomous (top-level) profiles for programs and devices whose central function is providing support for storage networking. This standard includes four autonomous profiles: Fabric, Switch, Extender and iSCSI to FC Gateway.

Single copy price: \$116.00

Obtain an electronic copy from: <http://webstore.ansi.org/>

Order from: <http://webstore.ansi.org/>

Send comments (with optional copy to psa@ansi.org) to: comments@standards.incits.org

ITI (INCITS) (InterNational Committee for Information Technology Standards)

700 K Street NW, Suite 600, Washington, DC 20001 p: (202) 737-8888 w: www.incits.org

Reaffirmation

Reaffirmations and withdrawals available electronically may be accessed at: webstore.ansi.org

INCITS/ISO/IEC 24775-7:2014 [R202x], Information technology - Storage management - Part 7: Host Elements (reaffirm a national adoption INCITS/ISO/IEC 24775-7:2014 [2016])

Defines management profiles for autonomous, component, and abstract profiles for management of host-based storage devices. The autonomous profiles describe the management of a stand-alone host-based storage entity. The component profiles (or subprofiles) describe management of aspects of host-based storage entities that may be used by other autonomous profiles. Finally, this standard describes abstract profiles that may be used as a basis for creating additional Host-based autonomous profiles.

Single copy price: \$116.00

Obtain an electronic copy from: <http://webstore.ansi.org/>

Order from: <http://webstore.ansi.org/>

Send comments (with optional copy to psa@ansi.org) to: comments@standards.incits.org

Comment Deadline: June 8, 2021

ITI (INCITS) (InterNational Committee for Information Technology Standards)

700 K Street NW, Suite 600, Washington, DC 20001 p: (202) 737-8888 w: www.incits.org

Reaffirmation

Reaffirmations and withdrawals available electronically may be accessed at: webstore.ansi.org

INCITS/ISO/IEC 24775-8:2014 [R202x], Information technology - Storage management - Part 8: Media Libraries (reaffirm a national adoption INCITS/ISO/IEC 24775-8:2014 [2016])

Models various details of the following objects of the media library for monitoring: Library, Drives, Changer Devices, Slots, IO Slots, SCSI Interfaces and SCSI and FC Target Ports, Physical Tapes, Physical Package, and Magazines.

Single copy price: \$116.00

Obtain an electronic copy from: <http://webstore.ansi.org/>

Order from: <http://webstore.ansi.org/>

Send comments (with optional copy to psa@ansi.org) to: comments@standards.incits.org

ITI (INCITS) (InterNational Committee for Information Technology Standards)

700 K Street NW, Suite 600, Washington, DC 20001 p: (202) 737-8888 w: www.incits.org

Reaffirmation

Reaffirmations and withdrawals available electronically may be accessed at: webstore.ansi.org

INCITS/ISO/IEC 29109-10:2010 [R202x], Information technology - Conformance testing methodology for biometric data interchange formats defined in ISO/IEC 19794 - Part 10: Hand geometry silhouette data (reaffirm a national adoption INCITS/ISO/IEC 29109-10:2010 [R2016])

Specifies elements of conformance-testing methodology, test assertions, and test procedures as applicable to ISO/IEC 19794 -10. This part of the standard establishes test assertions of the structure of the hand geometry silhouette data format; test assertions of internal consistency by checking the types of values that may be contained within each field; and informative guidance for testing the consistency of selected encoded data fields with the input biometric data.

Single copy price: \$60.00

Obtain an electronic copy from: <http://webstore.ansi.org/>

Order from: <http://webstore.ansi.org/>

Send comments (with optional copy to psa@ansi.org) to: comments@standards.incits.org

ITI (INCITS) (InterNational Committee for Information Technology Standards)

700 K Street NW, Suite 600, Washington, DC 20001 p: (202) 737-8888 w: www.incits.org

Reaffirmation

Reaffirmations and withdrawals available electronically may be accessed at: webstore.ansi.org

INCITS/ISO/IEC 29120-1:2015 [R202x], Information technology - Machine readable test data for biometric testing and reporting - Part 1: Test reports (reaffirm a national adoption INCITS/ISO/IEC 29120-1:2015 [2016])

Establishes machine-readable records for documenting the output of a biometric test, formats for data that ISO/IEC 19795 tests are required to report, and an ASN.1 syntax for test reports. This standard specifically does not require, prohibit, or otherwise specify the format of biometric samples or templates used in a test; require, prohibit, or otherwise specify the encapsulation of biometric samples or templates used in a test; or regulate metrics for tests. NOTE - ISO/IEC 19795-1 establishes the reportable metrics.

Single copy price: \$100.00

Obtain an electronic copy from: <http://webstore.ansi.org/>

Order from: <http://webstore.ansi.org/>

Send comments (with optional copy to psa@ansi.org) to: comments@standards.incits.org

Comment Deadline: June 8, 2021

ITI (INCITS) (InterNational Committee for Information Technology Standards)

700 K Street NW, Suite 600, Washington, DC 20001 p: (202) 737-8888 w: www.incits.org

Reaffirmation

Reaffirmations and withdrawals available electronically may be accessed at: webstore.ansi.org

INCITS/ISO/IEC 29159-1:2010 [R202x], Information technology - Biometric calibration, augmentation, and fusion data - Part 1: Fusion information format (reaffirm a national adoption INCITS/ISO/IEC 29159-1:2010 [R2016])

Specifies a biometric fusion information format that establishes machine readable data formats to describe the statistics of comparison score inputs to a fusion process. Does not standardize comparison-score normalization processes, nor standardize or define fusion processes.

Single copy price: \$60.00

Obtain an electronic copy from: <http://webstore.ansi.org/>

Order from: <http://webstore.ansi.org/>

Send comments (with optional copy to psa@ansi.org) to: comments@standards.incits.org

ITI (INCITS) (InterNational Committee for Information Technology Standards)

700 K Street NW, Suite 600, Washington, DC 20001 p: (202) 737-8888 w: www.incits.org

Reaffirmation

Reaffirmations and withdrawals available electronically may be accessed at: webstore.ansi.org

INCITS/ISO/IEC 4909:2006 [R202x], Identification cards - Financial transaction cards - Magnetic stripe data content for track 3 (reaffirm a national adoption INCITS/ISO/IEC 4909:2006 [R2016])

Establishes specifications for financial transaction cards using track 3 and is intended to permit interchange based on the use of magnetic stripe encoded information. It specifies the data content and physical location of read/write information on track 3 and is to be used in conjunction with the relevant parts of ISO/IEC 7811 and ISO/IEC 7812.

Single copy price: \$60.00

Obtain an electronic copy from: <http://webstore.ansi.org/>

Order from: <http://webstore.ansi.org/>

Send comments (with optional copy to psa@ansi.org) to: comments@standards.incits.org

ITI (INCITS) (InterNational Committee for Information Technology Standards)

700 K Street NW, Suite 600, Washington, DC 20001 p: (202) 737-8888 w: www.incits.org

Reaffirmation

Reaffirmations and withdrawals available electronically may be accessed at: webstore.ansi.org

INCITS/ISO/IEC 14750:1999 [R202x], Information Technology - Open Distributed Processing - Interface Definition Language (reaffirm a national adoption INCITS/ISO/IEC 14750:1999 [R2016])

Provides the ODP Reference Model (see ITU-T Rec. X.902 | ISO/IEC 10746-2 and ITU-T Rec. X.903 | ISO/IEC 10746-3) with a language- and environment-neutral notation to describe computational operation interface signatures. Use of this notation does not imply use of specific supporting mechanisms and protocols.

Single copy price: \$60.00

Obtain an electronic copy from: <http://webstore.ansi.org/>

Order from: <http://webstore.ansi.org/>

Send comments (with optional copy to psa@ansi.org) to: comments@standards.incits.org

Comment Deadline: June 8, 2021

ITI (INCITS) (InterNational Committee for Information Technology Standards)

700 K Street NW, Suite 600, Washington, DC 20001 p: (202) 737-8888 w: www.incits.org

Reaffirmation

Reaffirmations and withdrawals available electronically may be accessed at: webstore.ansi.org

INCITS/ISO/IEC 14752:2000 [R202x], Information Technology - Open Distributed Processing - Protocol Support for Computational Interactions (reaffirm a national adoption INCITS/ISO/IEC 14752:2000 [R2016])

Defines how interactions between computational objects in a computational specification of a system relate to protocol support for those interactions in an engineering specification of that system.

Single copy price: \$60.00

Obtain an electronic copy from: <http://webstore.ansi.org/>

Order from: <http://webstore.ansi.org/>

Send comments (with optional copy to psa@ansi.org) to: comments@standards.incits.org

ITI (INCITS) (InterNational Committee for Information Technology Standards)

700 K Street NW, Suite 600, Washington, DC 20001 p: (202) 737-8888 w: www.incits.org

Reaffirmation

Reaffirmations and withdrawals available electronically may be accessed at: webstore.ansi.org

INCITS/ISO/IEC 14753:1999 [R202x], Information Technology - Open Distributed Processing - Interface References and Binding (reaffirm a national adoption INCITS/ISO/IEC 14753:1999 [R2016])

Interface references are crucial to interworking between ODP systems and federation of groups of ODP systems. An interface reference embodies the information needed to establish bindings, including binding to objects at nodes that support several different communication protocols and binding to objects in different management domains.

Single copy price: \$60.00

Obtain an electronic copy from: <http://webstore.ansi.org/>

Order from: <http://webstore.ansi.org/>

Send comments (with optional copy to psa@ansi.org) to: comments@standards.incits.org

ITI (INCITS) (InterNational Committee for Information Technology Standards)

700 K Street NW, Suite 600, Washington, DC 20001 p: (202) 737-8888 w: www.incits.org

Reaffirmation

Reaffirmations and withdrawals available electronically may be accessed at: webstore.ansi.org

INCITS/ISO/IEC 14769:2001 [R202x], Information Technology - Open Distributed Processing - Type Repository Function (reaffirm a national adoption INCITS/ISO/IEC 14769:2001 [R2016])

Defines a framework for describing types of interest in ODP systems by determining what entities need to be typed and what needs to be said about the identified types.

Single copy price: \$60.00

Obtain an electronic copy from: <http://webstore.ansi.org/>

Order from: <http://webstore.ansi.org/>

Send comments (with optional copy to psa@ansi.org) to: comments@standards.incits.org

Comment Deadline: June 8, 2021

ITI (INCITS) (InterNational Committee for Information Technology Standards)

700 K Street NW, Suite 600, Washington, DC 20001 p: (202) 737-8888 w: www.incits.org

Reaffirmation

Reaffirmations and withdrawals available electronically may be accessed at: webstore.ansi.org

INCITS/ISO/IEC 14771:1999 [R202x], Information Technology - Open Distributed Processing - Naming Framework (reaffirm a national adoption INCITS/ISO/IEC 14771:1999 [R2016])

Defines a general framework for context-relative naming, refining and elaborating on the naming concepts defined in Part 2 of the ODP-RM; Identifies and characterizes functions necessary to handle names in the context of a federation of different naming systems; and clarifies the relationship between the concepts of name management (i.e., federation and naming) in distributed computing systems.

Single copy price: \$60.00

Obtain an electronic copy from: <http://webstore.ansi.org/>

Order from: <http://webstore.ansi.org/>

Send comments (with optional copy to psa@ansi.org) to: comments@standards.incits.org

ITI (INCITS) (InterNational Committee for Information Technology Standards)

700 K Street NW, Suite 600, Washington, DC 20001 p: (202) 737-8888 w: www.incits.org

Reaffirmation

Reaffirmations and withdrawals available electronically may be accessed at: webstore.ansi.org

INCITS/ISO/IEC 16485:2000 [R202x], Information technology - Mixed Raster Content (MRC) (reaffirm a national adoption INCITS/ISO/IEC 16485:2000 [R2016])

Defines a means to efficiently represent raster-oriented pages that contain a mixture of multi-level and bi-level images. Any of the many ITU-T recommended encoding schemes, such as T.81 (JPEG) for the encoding of multi-level images and T.6 (MMR) for the encoding of bi-level images, may be combined within the context of this Recommendation.

Single copy price: \$81.00

Obtain an electronic copy from: <http://webstore.ansi.org/>

Order from: <http://webstore.ansi.org/>

Send comments (with optional copy to psa@ansi.org) to: comments@standards.incits.org

ITI (INCITS) (InterNational Committee for Information Technology Standards)

700 K Street NW, Suite 600, Washington, DC 20001 p: (202) 737-8888 w: www.incits.org

Reaffirmation

Reaffirmations and withdrawals available electronically may be accessed at: webstore.ansi.org

INCITS/ISO/IEC 29183:2010 [R202x], Information technology - Office equipment - Method for measuring digital copying productivity of a single one-sided original (reaffirm a national adoption INCITS/ISO/IEC 29183:2010 [R2016])

Specifies a method for measuring productivity of digital copying devices and multifunctional devices with various copying modes and a single one-sided original. It is applicable to digital copying devices and multifunctional devices. It is intended to be used for black-and-white and color digital copying devices and multifunctional devices of any underlying marking technology. This International Standard includes instructions for the creation of test charts, test setup procedure, test procedure, and the reporting requirements for the digital copying productivity measurements.

Single copy price: \$60.00

Obtain an electronic copy from: <http://webstore.ansi.org/>

Order from: <http://webstore.ansi.org/>

Send comments (with optional copy to psa@ansi.org) to: comments@standards.incits.org

Comment Deadline: June 8, 2021

ITI (INCITS) (InterNational Committee for Information Technology Standards)

700 K Street NW, Suite 600, Washington, DC 20001 p: (202) 737-8888 w: www.incits.org

Reaffirmation

Reaffirmations and withdrawals available electronically may be accessed at: webstore.ansi.org

INCITS/ISO/IEC 29197:2015 [R202x], Information technology - Evaluation methodology for environmental influence in biometric system performance (reaffirm a national adoption INCITS/ISO/IEC 29197:2015 [2016])

Addresses fundamental requirements for planning and execution of environmental performance evaluations for biometric systems based on scenario and operational test methodologies; specifications to define, establish, and measure specific conditions to assess, including requirements for equipment, requirements for establishing a baseline performance in order to compare the influence of environmental parameters; a specification of the biometric evaluation including requirements for test population, test protocols, data to record, and test results; and procedures for carrying out the overall evaluation.

Single copy price: \$75.00

Obtain an electronic copy from: <http://webstore.ansi.org/>

Order from: <http://webstore.ansi.org/>

Send comments (with optional copy to psa@ansi.org) to: comments@standards.incits.org

ITI (INCITS) (InterNational Committee for Information Technology Standards)

700 K Street NW, Suite 600, Washington, DC 20001 p: (202) 737-8888 w: www.incits.org

Stabilized Maintenance

Reaffirmations and withdrawals available electronically may be accessed at: webstore.ansi.org

INCITS 418-2006 [S202x], Information Technology - Switch Fabric - Generation 4 (FC-SW-4) (stabilized maintenance of INCITS 418-2006 [R2016])

Describes the requirements for an interconnecting Fabric consisting of multiple Fabric Switch elements to support the INCITS Fibre Channel - Framing and Signaling (FC-FS) and INCITS Fibre Channel - Physical Interface (FC-PI) standards.

Single copy price: \$60.00

Obtain an electronic copy from: <http://webstore.ansi.org/>

Order from: <http://webstore.ansi.org/>

Send comments (with optional copy to psa@ansi.org) to: comments@standards.incits.org

ITI (INCITS) (InterNational Committee for Information Technology Standards)

700 K Street NW, Suite 600, Washington, DC 20001 p: (202) 737-8888 w: www.incits.org

Stabilized Maintenance

Reaffirmations and withdrawals available electronically may be accessed at: webstore.ansi.org

INCITS 460-2011 [S202x], Information Technology - Fibre Channel - Physical Interface - 3 (FC-PI-3) (stabilized maintenance of INCITS 460-2011 [R2016])

Describes the physical interface portions of a high-performance serial link based on the work of the XFP MSA. FC-PI-3 applies only to the variant described in FC-PI-3 and does not affect or supersede any requirements in any other FC standard or technical report. defines the electrical interfaces called XFI+ based on INF 8077(XFI) the XFP MSA for high-speed serial operation from 9.95-11.1 Gigabaud.

Single copy price: \$60.00

Obtain an electronic copy from: <http://webstore.ansi.org/>

Order from: <http://webstore.ansi.org/>

Send comments (with optional copy to psa@ansi.org) to: comments@standards.incits.org

Comment Deadline: June 8, 2021

ITI (INCITS) (InterNational Committee for Information Technology Standards)

700 K Street NW, Suite 600, Washington, DC 20001 p: (202) 737-8888 w: www.incits.org

Stabilized Maintenance

Reaffirmations and withdrawals available electronically may be accessed at: webstore.ansi.org

INCITS 466-2011 [S202x], Information Technology - Fibre Channel - Single-Byte Command Code Sets Mapping Protocol - 4 (FC-SB-4) (stabilized maintenance of INCITS 466-2011 [R2016])

Describes a communication interface between a channel and I/O control units that utilize the Single-Byte Command Code Sets (SBCCS) as implemented in a wide range of data processing systems.

Single copy price: \$60.00

Obtain an electronic copy from: <http://webstore.ansi.org/>

Order from: <http://webstore.ansi.org/>

Send comments (with optional copy to psa@ansi.org) to: comments@standards.incits.org

ITI (INCITS) (InterNational Committee for Information Technology Standards)

700 K Street NW, Suite 600, Washington, DC 20001 p: (202) 737-8888 w: www.incits.org

Stabilized Maintenance

Reaffirmations and withdrawals available electronically may be accessed at: webstore.ansi.org

INCITS 470-2011 [S202x], Information technology - Fibre Channel - Framing and Signaling - 3 (FC-FS-3) (stabilized maintenance of INCITS 470-2011 [R2016])

Describes the framing and signaling interface of a high-performance serial link for support of FC-4s associated with upper-level protocols (e.g., SCSI, IP, SBCCS, VI). This standard is based on FC-FS-2 (ISO/IEC 14165-252) with subsequent modifications approved by the member body that originally authored and approved FC-FS-2.

Single copy price: \$60.00

Obtain an electronic copy from: <http://webstore.ansi.org/>

Order from: <http://webstore.ansi.org/>

Send comments (with optional copy to psa@ansi.org) to: comments@standards.incits.org

ITI (INCITS) (InterNational Committee for Information Technology Standards)

700 K Street NW, Suite 600, Washington, DC 20001 p: (202) 737-8888 w: www.incits.org

Stabilized Maintenance

Reaffirmations and withdrawals available electronically may be accessed at: webstore.ansi.org

INCITS 475-2011 [S202x], Information Technology - Fibre Channel - Inter-Fabric Routing (FC-IFR) (stabilized maintenance of INCITS 475-2011 [R2016])

The Fibre Channel Inter-Fabric Routing (FC-IFR) standard defines the protocols, functions, and mappings for the routing of Fibre Channel frames between physically or logically separated Fabrics.

Single copy price: \$60.00

Obtain an electronic copy from: <http://webstore.ansi.org/>

Order from: <http://webstore.ansi.org/>

Send comments (with optional copy to psa@ansi.org) to: comments@standards.incits.org

Comment Deadline: June 8, 2021

ITI (INCITS) (InterNational Committee for Information Technology Standards)

700 K Street NW, Suite 600, Washington, DC 20001 p: (202) 737-8888 w: www.incits.org

Stabilized Maintenance

Reaffirmations and withdrawals available electronically may be accessed at: webstore.ansi.org

INCITS 477-2011 [S202x], Information Technology - Fibre Channel - Link Services - 2 (FC-LS-2) (stabilized maintenance of INCITS 477-2011 [R2016])

Describes the Link Services requirements. The Physical Interface requirements are described in Fibre Channel-Physical Interfaces - 2 (FC-PI-2). The Framing and Signaling requirements are described in Fibre Channel-Physical Framing and Signaling - 3 (FC-FS-3). This standard is recommended for new implementations but does not obsolete the existing Fibre Channel standards.

Single copy price: \$60.00

Obtain an electronic copy from: <http://webstore.ansi.org/>

Order from: <http://webstore.ansi.org/>

Send comments (with optional copy to psa@ansi.org) to: comments@standards.incits.org

ITI (INCITS) (InterNational Committee for Information Technology Standards)

700 K Street NW, Suite 600, Washington, DC 20001 p: (202) 737-8888 w: www.incits.org

Stabilized Maintenance

Reaffirmations and withdrawals available electronically may be accessed at: webstore.ansi.org

INCITS 479-2011 [S202x], Information Technology - Fibre Channel - Physical Interface-5 - (FC-PI-5/AM1) (stabilized maintenance of INCITS 479-2011 [R2016])

Describes the physical interface portions of high-performance electrical and optical link variants that support the higher-level Fibre Channel protocols including FC-FS-2 and the higher Upper Level Protocols (ULPs) associated with HIPPI, SCSI, IP and others.

Single copy price: \$60.00

Obtain an electronic copy from: <http://webstore.ansi.org/>

Order from: <http://webstore.ansi.org/>

Send comments (with optional copy to psa@ansi.org) to: comments@standards.incits.org

ITI (INCITS) (InterNational Committee for Information Technology Standards)

700 K Street NW, Suite 600, Washington, DC 20001 p: (202) 737-8888 w: www.incits.org

Stabilized Maintenance

Reaffirmations and withdrawals available electronically may be accessed at: webstore.ansi.org

INCITS 480-2011 [S202x], Information technology - BIOS Enhanced Disk Drive Services - 4 (EDD-4) (stabilized maintenance of INCITS 480-2011 [R2016])

This standard assumes that the reader is familiar with the conventional INT 13h interface, the usage of the BIOS Device Parameter Table, and the basic operation of mass storage devices. This standard describes in detail BIOS functions and data structures that are used as an abstraction layer to allow higher-level applications to access mass storage devices in an interface and command-set independent manner. To comply with this standard, higher-level software shall call the INT functions using the data structures described in this standard, and system firmware shall provide the INT functions and data structures described in this standard.

Single copy price: \$60.00

Obtain an electronic copy from: <http://webstore.ansi.org/>

Order from: <http://webstore.ansi.org/>

Send comments (with optional copy to psa@ansi.org) to: comments@standards.incits.org

Comment Deadline: June 8, 2021

ITI (INCITS) (InterNational Committee for Information Technology Standards)

700 K Street NW, Suite 600, Washington, DC 20001 p: (202) 737-8888 w: www.incits.org

Stabilized Maintenance

Reaffirmations and withdrawals available electronically may be accessed at: webstore.ansi.org

INCITS/ISO/IEC 14165-133:2010 [S202x], Information technology - Fibre Channel - Part 133: Switch Fabric-3 (FC-SW-3) (stabilized maintenance of INCITS/ISO/IEC 14165-133:2010 [R2016])

Describes the operation and interaction of Fibre Channel Switches and includes: (a) EPort Operation and Fabric Configuration; (b) Path selection (FSPF and FSPF-Backbone); (c) Bridge Port (BPort) Operation; (d) distributed server interaction and communication; (e) exchange of information between Switches to support zoning; and (f) distribution of Event Notifications between Switches.

Single copy price: \$60.00

Obtain an electronic copy from: <http://webstore.ansi.org/>

Order from: <http://webstore.ansi.org/>

Send comments (with optional copy to psa@ansi.org) to: comments@standards.incits.org

ITI (INCITS) (InterNational Committee for Information Technology Standards)

700 K Street NW, Suite 600, Washington, DC 20001 p: (202) 737-8888 w: www.incits.org

Stabilized Maintenance

Reaffirmations and withdrawals available electronically may be accessed at: webstore.ansi.org

INCITS/ISO/IEC 14165-321:2009 [S202x], Information technology - Fibre Channel - Part 321: Audio-Video (FC-AV) (stabilized maintenance of INCITS/ISO/IEC 14165-321:2009 [R2016])

Specifies the transport of digital Audio and Video formats over Fibre Channel. Specifications are included for a coherent framework (i.e., an FC-AV Container and Objects) for mapping current and future digital Audio and Video formats to Fibre Channel; mapping the formats defined by the ITU-R BT-601 and SMPTE family of standards to Fibre Channel; mapping the formats defined by the ISO/IEC 3818 family of standards (which include MPEG and related compression systems) to Fibre Channel; a profile (i.e., Simple Parametric Digital Video) that parametrically defines the characteristics of Audio and Video information for specific applications; and, data packing guidelines recommended for AV data within the Fibre Channel transmission words.

Single copy price: \$116.00

Obtain an electronic copy from: <http://webstore.ansi.org/>

Order from: <http://webstore.ansi.org/>

Send comments (with optional copy to psa@ansi.org) to: comments@standards.incits.org

ITI (INCITS) (InterNational Committee for Information Technology Standards)

700 K Street NW, Suite 600, Washington, DC 20001 p: (202) 737-8888 w: www.incits.org

Stabilized Maintenance

Reaffirmations and withdrawals available electronically may be accessed at: webstore.ansi.org

INCITS/ISO/IEC 14165-331:2007 [S202x], Information technology - Fibre Channel - Part 331: Virtual Interface (FC-VI) (stabilized maintenance of INCITS/ISO/IEC 14165-331:2007 [R2016])

Defines the Fibre Channel mapping protocol for the Virtual Interface (VI) Architecture (FC-VI). FC-VI defines the Fibre Channel Information Units in accordance with the VI Architecture model. FC-VI additionally defines how Fibre Channel services are used to perform the services required by the VI Architecture model of its network transport.

Single copy price: \$60.00

Obtain an electronic copy from: <http://webstore.ansi.org/>

Order from: <http://webstore.ansi.org/>

Send comments (with optional copy to psa@ansi.org) to: comments@standards.incits.org

Comment Deadline: June 8, 2021

ITI (INCITS) (InterNational Committee for Information Technology Standards)

700 K Street NW, Suite 600, Washington, DC 20001 p: (202) 737-8888 w: www.incits.org

Stabilized Maintenance

Reaffirmations and withdrawals available electronically may be accessed at: webstore.ansi.org

INCITS/ISO/IEC 14776-453:2009 [S202x], Information technology - Small computer system interface (SCSI) - Part 453: Primary commands-3 (SPC-3) (stabilized maintenance of INCITS/ISO/IEC 14776-453:2009 [R2016])

Defines the SCSI commands that are mandatory and optional for all SCSI devices. Support for any feature defined in this standard is optional unless otherwise stated. This standard also defines the SCSI commands that may apply to any device model.

Single copy price: \$116.00

Obtain an electronic copy from: <http://webstore.ansi.org/>

Order from: <http://webstore.ansi.org/>

Send comments (with optional copy to psa@ansi.org) to: comments@standards.incits.org

ITI (INCITS) (InterNational Committee for Information Technology Standards)

700 K Street NW, Suite 600, Washington, DC 20001 p: (202) 737-8888 w: www.incits.org

Withdrawal

Reaffirmations and withdrawals available electronically may be accessed at: webstore.ansi.org

INCITS 526-2016, Information Technology - Next Generation Access Control - Generic Operations And Data Structures (NGAC-GOADS) (withdrawal of INCITS 526-2016)

Provides a detailed refinement of the definitions and concepts in the access control architecture and framework defined by the NGAC-FA standard. To provide a precise specification of the abstractions involved, the refinements are based on the mathematics of set theory and predicate calculus in consonance with the Z notation. By capturing the essential properties of NGAC mathematically, free from constraints on how these properties are achieved, NGAC-GOADS serves as a formal, conceptual model for the composition and working of NGAC.

Single copy price: \$60.00

Obtain an electronic copy from: <http://webstore.ansi.org/>

Order from: <http://webstore.ansi.org/>

Send comments (with optional copy to psa@ansi.org) to: comments@standards.incits.org

ITI (INCITS) (InterNational Committee for Information Technology Standards)

700 K Street NW, Suite 600, Washington, DC 20001 p: (202) 737-8888 w: www.incits.org

Withdrawal

Reaffirmations and withdrawals available electronically may be accessed at: webstore.ansi.org

INCITS/ISO/IEC 10373-1:2006 [R2016], Cards and security devices for personal identification - Test methods - Part 1: General characteristics (withdrawal of INCITS/ISO/IEC 10373-1:2006 [R2016])

Describes the test methods for characteristics of identification cards according to ISO/IEC 7810 and other standards, such as those listed in the Introduction.

Single copy price: \$60.00

Obtain an electronic copy from: <http://webstore.ansi.org/>

Order from: <http://webstore.ansi.org/>

Send comments (with optional copy to psa@ansi.org) to: comments@standards.incits.org

Comment Deadline: June 8, 2021

UL (Underwriters Laboratories)

171 Nepean Street, Suite 400, Ottawa, ON K2P 0B4 Canada p: (613) 368-4417 61017 w: <https://ul.org/>

New Standard

Reaffirmations and withdrawals available electronically may be accessed at: webstore.ansi.org

BSR/UL 536-202x, Standard for Safety for Flexible Metallic Hose (new standard)

This Standard puts forth requirements covering flexible metallic hose supplied with fittings on each end that facilitate connection without twisting the hose. They have a corrugated metal core or a nonmetallic inner core which are covered with a stainless steel braid. They have a nominal inside diameter of not more than 4 in (101 mm) intended for use in piping systems carrying compressed gases, such as anhydrous ammonia, and combustible fuel gases such as natural gas, liquefied petroleum gas, propane, and butane, at pressures not exceeding 500 psig (3.45 MPa) and temperatures not greater than 450°F (232°C) or lower than -40°F (-40°C). Flexible metallic hose is intended for aboveground applications and for underground applications not involving contact with soil. Flexible metallic hose is not considered a substitute for standard pipe or tubing and its use should be confined to applications where flexible connections cannot be avoided. This standard does not apply to hose connectors used in natural gas processing plants, refineries, petrochemical plants, marine terminals, or gas-transmission and distribution-piping systems.

Single copy price: Free

Obtain an electronic copy from: <https://csds.ul.com/Home/ProposalsDefault.aspx>

Order from: <http://www.shopulstandards.com>

Send comments (with optional copy to psa@ansi.org) to: Follow the instructions in the following website to enter comments into the CSDS Work Area: <https://csds.ul.com/Home/ProposalsDefault.aspx>

Project Withdrawn

In accordance with clause 4.2.1.3.3 Discontinuance of a standards project of the ANSI Essential Requirements, an accredited standards developer may abandon the processing of a proposed new or revised American National Standard or portion thereof if it has followed its accredited procedures. The following projects have been withdrawn accordingly:

AGMA (American Gear Manufacturers Association)

1001 N Fairfax Street, 5th Floor, Alexandria, VA 22314-1587 p: (703) 684-0211 w: www.agma.org

BSR/AGMA ISO 6336-6-BXX-202x, Calculation of load capacity of spur and helical gears - Part 6: Calculation of service life under variable load (identical national adoption of ISO 6336-6:2019)

Inquiries may be directed to Amir Aboutaleb; tech@agma.org

API (American Petroleum Institute)

200 Massachusetts Avenue NW, Washington, DC 20001 p: (202) 682-8286 w: www.api.org

BSR/API Spec 10D/ISO 10427-1-2010 (R202x), Specification for Bow-Spring Casing Centralizers (reaffirm a national adoption ANSI/API Spec 10D/ISO 10427-1-2010 (R2015))

Inquiries may be directed to Jacqueline Roueche; RouecheJ@api.org

NEMA (ASC Z535) (National Electrical Manufacturers Association)

1300 North 17th Street, Suite 900, Rosslyn, VA 22209 p: (703) 477-9997 w: www.nema.org

BSR Z535.1-2006 (R201x), Standard for Safety Colors (reaffirmation of ANSI Z535.1-2006)

Inquiries may be directed to Paul Orr; orrpaul@aol.com

NEMA (ASC Z535) (National Electrical Manufacturers Association)

1300 North 17th Street, Suite 900, Rosslyn, VA 22209 p: (703) 477-9997 w: www.nema.org

BSR Z535.3-202x, Criteria for Safety Symbols (revision of ANSI Z535.3-2011 (R2017))

Inquiries may be directed to Paul Orr; orrpaul@aol.com

Project Withdrawn

NEMA (ASC Z535) (National Electrical Manufacturers Association)

1300 North 17th Street, Suite 900, Rosslyn, VA 22209 p: (703) 477-9997 w: www.nema.org

BSR Z535-202x, Safety Color Chart for Use with ANSI Z535 Standards (new standard)

Inquiries may be directed to Paul Orr; orrpaul@aol.com

NEMA (National Electrical Manufacturers Association)

1300 North 17th Street, Suite 900, Arlington, VA 22209 p: (703) 841-3236 w: www.nema.org

BSR/NEMA VE1-202x, Metal Cable Tray Systems (new standard)

Inquiries may be directed to Megan Hayes; megan.hayes@nema.org

Withdrawal of an ANS by ANSI-Accredited Standards Developer

In accordance with clause 4.2.1.3.2 Withdrawal by ANSI-Accredited Standards Developer of the ANSI Essential Requirements, the following American National Standards have been withdrawn as an ANS.

API (American Petroleum Institute)

200 Massachusetts Avenue NW, Washington, DC 20001 p: (202) 682-8286 w: www.api.org

ANSI/API Spec 10D/ISO 10427-1-2010 (R2015), Specification for Bow-Spring Casing Centralizers

Questions may be directed to: Jacqueline Roueche; RouecheJ@api.org

In accordance with clause 4.2.1.3.2 Withdrawal by ANSI-Accredited Standards Developer of the ANSI Essential Requirements, the following American National Standards have been withdrawn as an ANS.

PSAI (Portable Sanitation Association International)

2626 E. 82nd Street, Suite 175, Bloomington, IN 55425 p: (952) 854-8300 w: www.psai.org

ANSI/PSAI Z4.1-2016, Sanitation in Places of Employment: Minimum Requirements

Questions may be directed to: Karleen Kos; karleenk@psai.org

In accordance with clause 4.2.1.3.2 Withdrawal by ANSI-Accredited Standards Developer of the ANSI Essential Requirements, the following American National Standards have been withdrawn as an ANS.

UL (Underwriters Laboratories)

12 Laboratory Drive, Research Triangle Park, NC 27709-3995 p: (919) 549-1313 w: <https://ul.org/>

ANSI/UL 1610-2016, Standard for Safety for Central-Station Burglar-Alarm Units

Questions may be directed to: Megan Sepper, (847) 664-3411, Megan.M.Sepper@ul.com

In accordance with clause 4.2.1.3.2 Withdrawal by ANSI-Accredited Standards Developer of the ANSI Essential Requirements, the following American National Standards have been withdrawn as an ANS.

UL (Underwriters Laboratories)

12 Laboratory Drive, Research Triangle Park, NC 27709-3995 p: (919) 549-1313 w: <https://ul.org/>

ANSI/UL 1610-2016a, Standard for Safety for Central-Station Burglar-Alarm Units

Questions may be directed to: Megan Sepper, (847) 664-3411, Megan.M.Sepper@ul.com

Withdrawal of an ANS by ANSI-Accredited Standards Developer

In accordance with clause 4.2.1.3.2 Withdrawal by ANSI-Accredited Standards Developer of the ANSI Essential Requirements, the following American National Standards have been withdrawn as an ANS.

UL (Underwriters Laboratories)

12 Laboratory Drive, Research Triangle Park, NC 27709-3995 p: (919) 549-1313 w: <https://ul.org/>

ANSI/UL 1610-2016b, Standard for Safety for Central-Station Burglar-Alarm Units

Questions may be directed to: Megan Sepper, (847) 664-3411, Megan.M.Sepper@ul.com

In accordance with clause 4.2.1.3.2 Withdrawal by ANSI-Accredited Standards Developer of the ANSI Essential Requirements, the following American National Standards have been withdrawn as an ANS.

UL (Underwriters Laboratories)

12 Laboratory Drive, Research Triangle Park, NC 27709-3995 p: (919) 549-1313 w: <https://ul.org/>

ANSI/UL 1610-2016c, Standard for Safety for Central-Station Burglar-Alarm Units

Questions may be directed to: Megan Sepper, (847) 664-3411, Megan.M.Sepper@ul.com

In accordance with clause 4.2.1.3.2 Withdrawal by ANSI-Accredited Standards Developer of the ANSI Essential Requirements, the following American National Standards have been withdrawn as an ANS.

UL (Underwriters Laboratories)

12 Laboratory Drive, Research Triangle Park, NC 27709-3995 p: (919) 549-1313 w: <https://ul.org/>

ANSI/UL 1610-2016d, Standard for Safety for Central-Station Burglar-Alarm Units

Questions may be directed to: Annabelle Hollen; Annabelle.Hollen@ul.org

Final Actions on American National Standards

The standards actions listed below have been approved by the ANSI Board of Standards Review (BSR) or by an ANSI-Audited Designator, as applicable.

AAMI (Association for the Advancement of Medical Instrumentation)

901 N. Glebe Road, Suite 300, Arlington, VA 22203 p: (703) 253-8274 w: www.aami.org

New Standard

ANSI/AAMI PC76-2021, Active implantable medical devices - Requirements and test protocols for safety of patients with pacemakers and ICDs exposed to magnetic resonance imaging (new standard) Final Action Date: 4/6/2021

ASHRAE (American Society of Heating, Refrigerating and Air-Conditioning Engineers, Inc.)

180 Technology Parkway, Peachtree Corners, GA 30092 p: (678) 539-1125 w: www.ashrae.org

Addenda

ANSI/ASHRAE/IES Addendum b to ANSI/ASHRAE/IES Standard 90.1-2019, Energy Standard for Buildings Except Low-Rise Residential Buildings (addenda to ANSI/ASHRAE/IES Standard 90.1-2019) Final Action Date: 3/31/2021

Reaffirmation

ANSI/ASHRAE Standard 70-2006 (R2021), Method of Testing for Rating the Performance of Air Outlets and Air Inlets (reaffirmation of ANSI/ASHRAE Standard 70-2006 (R2011)) Final Action Date: 3/31/2021

Revision

ANSI/ASHRAE Standard 41.7-2021, Standard Methods for Gas Flow Measurement (revision of ANSI/ASHRAE Standard 41.7-2015) Final Action Date: 3/31/2021

Revision

ANSI/ASHRAE Standard 41.9-2021, Standard Methods for Refrigerant Mass Flow Measurements Using Calorimeters (revision of ANSI/ASHRAE Standard 41.9-2018) Final Action Date: 3/31/2021

Revision

ANSI/ASHRAE Standard 138-2021, Method of Testing for Rating Ceiling Panels for Sensible Heating and Cooling (revision of ANSI/ASHRAE Standard 138-2013 (R2016)) Final Action Date: 3/31/2021

AWWA (American Water Works Association)

6666 W. Quincy Avenue, Denver, CO 80235 p: (303) 347-6178 w: www.awwa.org

Revision

ANSI/AWWA C671-2021, Online Turbidimeter Operation and Maintenance (revision of ANSI/AWWA C671-2015) Final Action Date: 4/5/2021

HPS (ASC N13) (Health Physics Society)

1313 Dolley Madison Blvd #402, McLean, VA 22101 p: (703) 790-1745 w: www.hps.org

Revision

ANSI N13.1-2021, Sampling and Monitoring Releases of Airborne Radioactive Substances from the Stacks and Ducts of Nuclear Facilities (revision of ANSI N13.1-2011) Final Action Date: 4/5/2021

IAPMO (ASSE Chapter) (ASSE International Chapter of IAPMO)

18927 Hickory Creek Drive, Suite 220, Mokena, IL 60448 p: (909) 519-0740 w: www.asse-plumbing.org

New Standard

ANSI/ASSE 1098-2021, Performance Requirements for Atmospheric Vacuum Breakers for Vacuum Toilet Assemblies and Galley Waste Disposal Units on Commercial Aircraft (new standard) Final Action Date: 4/5/2021

NEMA (ASC C50) (National Electrical Manufacturers Association)

1300 N 17th Street, Suite 900, Rosslyn, VA 22209 p: (703) 841-3264 w: www.nema.org

Reaffirmation

ANSI C50.41-2012 (R2021), Polyphase Induction Motors for Power Generating Stations (reaffirmation of ANSI C50.41-2012) Final Action Date: 4/5/2021

NSF (NSF International)

789 N. Dixboro Road, Ann Arbor, MI 48105-9723 p: (734) 827-3817 w: www.nsf.org

Revision

ANSI/NSF 4-2021 (i32r2), Commercial Cooking, Rethermalization, and Powered Hot Food Holding and Transportation Equipment (revision of ANSI/NSF 4-2019) Final Action Date: 4/4/2021

Revision

ANSI/NSF 6-2021 (i19r1), Dispensing Freezers (revision of ANSI/NSF 6-2018) Final Action Date: 3/29/2021

Revision

ANSI/NSF 18-2021 (i19r2), Manual Food and Beverage Dispensing Equipment (revision of ANSI/NSF 18-2016) Final Action Date: 4/4/2021

Revision

ANSI/NSF 25-2021 (i19r1), Vending Machines for Food and Beverages (revision of ANSI/NSF 25-2017) Final Action Date: 3/29/2021

Withdrawal

ANSI/NSF 240-2021 (i4r1), Drainfield Trench Product Sizing for Gravity Dispersal Onsite Wastewater Treatment and Dispersal Systems (withdrawal of ANSI/NSF 240-2011 (R2017) (i2r1)) Final Action Date: 3/29/2021

UL (Underwriters Laboratories)

333 Pfingsten Road, Northbrook, IL 60062 p: (847) 664-1292 w: <https://ul.org/>

New Standard

ANSI/UL 3100-2021, Standard for Safety for Automated Mobile Platforms (AMPs) (new standard) Final Action Date: 4/5/2021

Reaffirmation

ANSI/UL 1012-2012 (R2021), Standard for Safety for Power Units Other than Class 2 (reaffirmation of ANSI/UL 1012-2012 (R2016)) Final Action Date: 3/30/2021

UL (Underwriters Laboratories)

333 Pfingsten Road, Northbrook, IL 60062 p: (847) 664-1292 w: <https://ul.org/>

Reaffirmation

ANSI/UL 60947-7-1-2017 (R2021), Standard for Safety for Low-Voltage Switchgear and Controlgear - Part 7-1 Ancillary Equipment - Terminal Blocks for Copper Conductors (reaffirmation of ANSI/UL 60947-7-1-2017) Final Action Date: 3/31/2021

Reaffirmation

ANSI/UL 60947-7-2-2017 (R2021), Standard for Safety for Low-Voltage Switchgear and Controlgear - Part 7-2 Ancillary Equipment - Protective Conductor Terminal Blocks for Copper Conductors (reaffirmation of ANSI/UL 60947-7-2-2017) Final Action Date: 3/31/2021

Reaffirmation

ANSI/UL 60947-7-3-2017 (R2021), Standard for Safety for Low-Voltage Switchgear and Controlgear - Part 7-3 Ancillary Equipment - Safety Requirements for Fuse Terminal Blocks (reaffirmation of ANSI/UL 60947-7-3-2017) Final Action Date: 3/31/2021

Revision

ANSI/UL 797-2021, Standard for Electrical Metallic Tubing - Steel (revision of ANSI/UL 797-2012 (R2017)) Final Action Date: 3/30/2021

Revision

ANSI/UL 1203-2021, Standard for Safety for Explosion-Proof and Dust-Ignition-Proof Electrical Equipment for Use in Hazardous (Classified) Locations (revision of ANSI/UL 1203-2020) Final Action Date: 3/31/2021

Revision

ANSI/UL 1696-2021, Standard for Mechanical Protection Tubing (MPT) and Fittings (revision of ANSI/UL 1696-2015) Final Action Date: 3/31/2021

Revision

ANSI/UL 2580-2021, Standard for Safety for Batteries for Use in Electric Vehicles (revision of ANSI/UL 2580-2020) Final Action Date: 3/31/2021

Revision

ANSI/UL 4248-19-2021, Standard for Safety for Fuseholders - Part 19: Photovoltaic Fuseholders (revision of ANSI/UL 4248-19-2015) Final Action Date: 3/31/2021

Revision

ANSI/UL 12402-5-2021, Standard for Personal Flotation Devices - Part 5: Buoyancy Aids (Level 50) - Safety Requirements (revision of ANSI/UL 12402-5-2019) Final Action Date: 3/30/2021

Revision

ANSI/UL 121201-2021, Standard for Safety for Nonincendive Electrical Equipment for Use in Class I and II, Division 2 and Class III, Divisions 1 and 2 Hazardous (Classified) Locations (revision of ANSI/UL 121201-2019) Final Action Date: 4/1/2021

Call for Members (ANS Consensus Bodies)

Directly and materially affected parties who are interested in participating as a member of an ANS consensus body for the standards listed below are requested to contact the sponsoring standards developer directly and in a timely manner.

AAMI (Association for the Advancement of Medical Instrumentation)

901 N. Glebe Road, Suite 300, Arlington, VA 22203 p: (703) 253-8261 w: www.aami.org

Colleen Elliott; celliott@aami.org

BSR/AAMI/ISO 80369-1-202x, Small-bore connectors for liquids and gases in healthcare applications - Part 1: General requirements (identical national adoption of ISO 80369-1 (Ed 3) and revision of ANSI/AAMI/ISO 80369-1-2018)

Solicit new consensus body members in the user, regulatory and general interest categories. Text to be sent to PSA.

BSR/AAMI/ISO 80369-20-202x, Small-bore connectors for liquids and gases in healthcare applications - Part 20: Common test methods (identical national adoption of ISO 80369-20 (Ed 2) and revision of ANSI/AAMI/ISO 80369-20-2015)

Solicit new consensus body members from user, regulatory and general interest categories. Text to be sent to PSA.

ASA (ASC S1) (Acoustical Society of America)

1305 Walt Whitman Road, Suite 300, Melville, NY 11747 p: (516) 576-2341 w: www.acousticalsociety.org

Nancy Blair-DeLeon; standards@acousticalsociety.org

BSR/ASA S1.15, Part 1-202x/IEC 61094-1-2000, Electroacoustics - Measurement microphones - Part 1: Specifications for laboratory standard microphones (identical national adoption of IEC 61094-1:2000)

BSR/ASA S1.15, Part 2-202x/IEC 61094-2-202x, Electroacoustics - Measurement microphones - Part 2: Primary method for pressure calibration of laboratory standard microphones by the reciprocity technique (identical national adoption of IEC 61094-2:2009 and revision of ANSI/ASA S1.15-2005/Part 2 (R2020))

ASABE (American Society of Agricultural and Biological Engineers)

2950 Niles Road, Saint Joseph, MI 49085 p: (269) 932-7015 w: <https://www.asabe.org/>

Carla VanGilder; vangilder@asabe.org

BSR/ASABE S648-4.1-202x, Agricultural Field Equipment Braking - Part 4: Requirements for Towed Vehicles (revision and redesignation of ANSI/ASABE S648-4 MONYEAR-2020)

BSR/ASABE S648-5.1 MONYEAR-202x, Agricultural Field Equipment Braking - Part 5: Requirements for the Interface between Towing Vehicle and Towed Vehicles (revision and redesignation of ANSI/ASABE S648-5 MAR2020)

BSR/ASABE/ISO 24347-202x, Agricultural vehicles - Mechanical connections between towed and towing vehicles - Dimensions of ball-type coupling device (80 mm) (identical national adoption of ISO 24347:2019 and revision of ANSI/ASABE AD24347:2014 (R2018))

ASABE (American Society of Agricultural and Biological Engineers)

2950 Niles Road, Saint Joseph, MI 49085 p: (269) 757-1213 w: <https://www.asabe.org/>

ASABE (American Society of Agricultural and Biological Engineers)

2950 Niles Road, Saint Joseph, MI 49085 p: (269) 757-1213 w: <https://www.asabe.org/>

Jean Walsh; walsh@asabe.org

BSR/ASABE EP653 MONYEAR-202x, Heating, Ventilating, and Air Conditioning (HVAC) for Indoor Plant Environments without Sunlight (new standard)

Additional Consensus Body members for User category, indoor growers, plant and horticulture specialists. Note: the Title has been modified from the PINS submission of: Recommended Practice for Heating, Ventilation and Air Conditioning (HVAC) Products Used in Indoor Plant Growth and Development, to the current title noted on this form. The designation was also corrected from the PINS.

ASME (American Society of Mechanical Engineers)

Two Park Avenue, M/S 6-2B, New York, NY 10016-5990 p: (212) 591-8489 w: www.asme.org

Terrell Henry; ansibox@asme.org

BSR/ASME PTC-51-202x, Gas Turbine Inlet Air-Conditioning Equipment (revision of ANSI/ASME PTC 51-2011 (R2016))

ASQ (ASC Z1) (American Society for Quality)

600 N Plankinton Avenue, Milwaukee, WI 53203 p: (800) 248-1946 w: www.asq.org

Julie Sharp; standards@asq.org

BSR/ASQ/ISO/TS 54001-202x, Quality management systems - Particular requirements for the application of ISO 9001:2015 for electoral organizations at all levels of government (identical national adoption of ISO/TS 54001:2019)

AWS (American Welding Society)

8669 NW 36th Street, Suite 130, Miami, FL 33166-6672 p: (305) 443-9353 306 w: www.aws.org

Kevin Bulger; kbulger@aws.org

BSR/AWS A5.31M/A5.31-202x, Specification for Fluxes for Brazing and Braze Welding (revision of ANSI/AWS A5.31M/A5.31-2012)

ECIA (Electronic Components Industry Association)

13873 Park Center Road, Suite 315, Herndon, VA 20171 p: (571) 323-0294 w: www.ecianow.org

Laura Donohoe; ldonohoe@ecianow.org

BSR/EIA 887-B-202x, Thin Film Resistor Network Specification (revision and redesignation of ANSI/EIA 887-A-2015)

FCI (Fluid Controls Institute)

1300 Sumner Avenue, Cleveland, OH 44115 p: (216) 241-7333 w: www.fluidcontrolsinstitute.org

Leslie Schraff; fci@fluidcontrolsinstitute.org

BSR/FCI 13-1-202x, Standard for Determining Condensate Loads to Size Steam Traps (revision of ANSI/FCI 13-1-2016)

FM (FM Approvals)

1151 Boston-Providence Tpke, Norwood, MA 02062 p: (781) 255-4846 w: www.fmglobal.com

Patrick Byrne; patrick.byrne@fmapprovals.com

BSR/FM 2500-202x, Examination Standard for Early Warning Flood Sensor Systems (new standard)

IES (Illuminating Engineering Society)

120 Wall Street, Floor 17, New York, NY 10005 p: (917) 913-0027 w: www.ies.org
 Patricia McGillicuddy; pmcgillicuddy@ies.org

BSR/IES LP-12-202x, Lighting Practice: IoT Connected Lighting (new standard)

BSR/IES TM-3x-202x, Technical Memorandum: Discomfort Glare under Low Light Conditions (new standard)

BSR/IES TM-202x- (Resilient Lighting), Technical Memorandum: Introduction to Resilient Lighting Systems (new standard)

ISA (International Society of Automation)

67 Alexander Drive, Research Triangle Park, NC 27709 p: (919) 990-9213 w: www.isa.org
 Charles Robinson; crobinson@isa.org

BSR/ISA 96.06.01-202x, Guidelines for the Specification of Self-Contained Electro-Hydraulic Valve Actuators (revision of ANSI/ISA 96.06.01-2014)

ITI (INCITS) (InterNational Committee for Information Technology Standards)

700 K Street NW, Suite 600, Washington, DC 20001 p: (202) 737-8888 w: www.incits.org
 Deborah Spittle; comments@standards.incits.org

INCITS 284-2011 [R202x], Information Technology - Identification Cards - Health Care Identification Cards (reaffirmation of INCITS 284-2011 [R2016])

INCITS 381-2009/AM 1:2011 [R202x], Information technology - Finger Image Based Data Interchange Format - Amendment 1 (reaffirmation of INCITS 381-2009/AM 1:2011 [R2016])

INCITS 409.4-2006 [R202x], Information technology - Biometric Performance Testing and Reporting - Part 4: Operational Testing Methodologies (reaffirmation of INCITS 409.4-2006 [R2016])

INCITS 409.5-2011 [R202x], Information Technology - Biometric Performance Testing and Reporting - Part 5: Framework for Testing and Evaluation of Biometric System(s) for Access Control (reaffirmation of INCITS 409.5-2011 [R2016])

INCITS 418-2006 [S202x], Information Technology - Switch Fabric - Generation 4 (FC-SW-4) (stabilized maintenance of INCITS 418-2006 [R2016])

INCITS 458-2011 [R202x], Information technology - SCSI Object-Based Storage Device Commands-2 (OSD-2) (reaffirmation of INCITS 458-2011 [R2016])

INCITS 459-2011 [R202x], Information Technology - Requirements for the Implementation and Interoperability of Role Based Access Control (reaffirmation of INCITS 459-2011 [R2016])

INCITS 460-2011 [S202x], Information Technology - Fibre Channel - Physical Interface - 3 (FC-PI-3) (stabilized maintenance of INCITS 460-2011 [R2016])

INCITS 466-2011 [S202x], Information Technology - Fibre Channel - Single-Byte Command Code Sets Mapping Protocol - 4 (FC-SB-4) (stabilized maintenance of INCITS 466-2011 [R2016])

INCITS 467-2011 [R202x], Information technology - SCSI Stream Commands - 3 (SSC-3) (reaffirmation of INCITS 467-2011 [R2016])

ITI (INCITS) (InterNational Committee for Information Technology Standards)

700 K Street NW, Suite 600, Washington, DC 20001 p: (202) 737-8888 w: www.incits.org

INCITS 470-2011 [S202x], Information technology - Fibre Channel - Framing and Signaling - 3 (FC-FS-3) (stabilized maintenance of INCITS 470-2011 [R2016])

INCITS 472-2011 [R202x], Information Technology - Automation/Drive Interface - Transport Protocol - 2 (ADT-2) (reaffirmation of INCITS 472-2011 [R2016])

INCITS 473-2011 [R202x], Information Technology - Conformance Testing Methodology Standard for Patron Formats Conforming to INCITS 398-2008, Information Technology - Common Biometric Exchange Formats Framework (CBEFF) (reaffirmation of INCITS 473-2011 [R2016])

INCITS 474-2011 [R202x], Information Technology - Biometric Application Programming Interface - Java (BioAPI Java) (reaffirmation of INCITS 474-2011 [R2016])

INCITS 475-2011 [S202x], Information Technology - Fibre Channel - Inter-Fabric Routing (FC-IFR) (stabilized maintenance of INCITS 475-2011 [R2016])

INCITS 477-2011 [S202x], Information Technology - Fibre Channel -Link Services - 2 (FC-LS-2) (stabilized maintenance of INCITS 477-2011 [R2016])

INCITS 478-2011 [R202x], Information technology - Serial Attached SCSI - 2.1 (SAS-2.1) (reaffirmation of INCITS 478-2011 [R2016])

INCITS 479-2011 [S202x], Information Technology - Fibre Channel - Physical Interface-5 (FC-PI-5/AM1) (stabilized maintenance of INCITS 479-2011 [R2016])

INCITS 479-2011/AM 1-2016 [R202x], Information Technology - Fibre Channel - Physical Interface - 5/Amendment 1 (FC-PI-5/AM1) (reaffirmation of INCITS 479-2011/AM 1-2016)

INCITS 480-2011 [S202x], Information technology - BIOS Enhanced Disk Drive Services - 4 (EDD-4) (stabilized maintenance of INCITS 480-2011 [R2016])

INCITS 481-2011 [R202x], Information technology - Fibre Channel Protocol for SCSI - 4 (FCP-4) (reaffirmation of INCITS 481-2011 [R2016])

INCITS 488-2016 [R202x], Information Technology - Fibre Channel - Framing and Signaling - 4 (FC-FS-4) (reaffirmation of INCITS 488-2016)

INCITS 501-2016 [R202x], Information technology - Security Features for SCSI Commands (SFSC) (reaffirmation of INCITS 501-2016)

INCITS 504-3-2016 [R202x], Information Technology - Generic Identity Command Set - Part 3: GICS Platform Testing Requirements (reaffirmation of INCITS 504-3-2016)

INCITS 504-1-2013/AM1-2016 [R202x], Information technology - Generic Identity Command Set -Part 1: Card Application Command Set - Amendment 1 (reaffirmation of INCITS 504-1-2013/AM1-2016)

INCITS 504-2-2013/AM 1-2016 [R202x], Information Technology - Generic Identity Command Set - Part 2: Card Administrative Command Set - Amendment 1 (reaffirmation of INCITS 504-2-2013/AM 1-2016)

INCITS 507-2016 [R202x], Information technology - PCIe[®] architecture Queuing Interface - 2(PQI-2) (reaffirmation of INCITS 507-2016)

INCITS 511-2016 [R202x], Information Technology - Fibre Channel - Switch Fabric - 6 (FC-SW-6) (reaffirmation of INCITS 511-2016)

ITI (INCITS) (InterNational Committee for Information Technology Standards)

700 K Street NW, Suite 600, Washington, DC 20001 p: (202) 737-8888 w: www.incits.org

INCITS 515-2016 [R202x], Information technology - SCSI Architecture Model - 5 (SAM-5) (reaffirmation of INCITS 515-2016)

INCITS 524-2016 [R202x], Information Technology - AT Attachment 8 - ATA/ATAPI Parallel Transport (ATA8-APT) (reaffirmation of INCITS 524-2016)

INCITS 526-2016, Information Technology - Next Generation Access Control - Generic Operations And Data Structures (NGAC-GOADS) (withdrawal of INCITS 526-2016)

INCITS 533-2016 [R202x], Information Technology - Fibre Channel - Physical Interface - 6P (FC-PI-6P) (reaffirmation of INCITS 533-2016)

INCITS 536-2016 [R202x], Information technology - Zoned Block Commands (ZBC) (reaffirmation of INCITS 536-2016)

INCITS 537-2016 [R202x], Information technology - Zoned Device ATA Command Set (ZAC) (reaffirmation of INCITS 537-2016)

INCITS 539-2016 [R202x], Information Technology - Management of Security Credentials (reaffirmation of INCITS 539-2016)

INCITS/ISO 19105:2000 [R202x], Geographic information - Conformance and testing (reaffirm a national adoption INCITS/ISO 19105:2000 [R2016])

INCITS/ISO 19123:2005 [R202x], Geographic Information - Schema for Coverage Geometry and Functions (reaffirm a national adoption INCITS/ISO 19123:2005 [R2016])

INCITS/ISO 19133:2005 [R202x], Geographic Information - Location Based Services - Tracking and Navigation (reaffirm a national adoption INCITS/ISO 19133:2005 [R2016])

INCITS/ISO 19142:2010 [R202x], Geographic Information - Web Feature Service (reaffirm a national adoption INCITS/ISO 19142:2010 [R2016])

INCITS/ISO 19143:2010 [R202x], Geographic Information - Filter Encoding (reaffirm a national adoption INCITS/ISO 19143:2010 [R2016])

INCITS/ISO 9542:1988/AM 1:1999 [R202x], Information processing systems - Telecommunications and information exchange between systems - End System to Intermediate System Routing Exchange Protocol for Use in Conjunction with the Protocol for Providing the Connectionless-Mode Network Service - Amendment 1: Addition of group composition information (reaffirm a national adoption INCITS/ISO 9542:1988/AM 1:1999 [R2016])

INCITS/ISO/IEC 7811-8:2014 [R202x], Identification cards - Recording technique - Part 8: Magnetic stripe - Coercivity of 51,7 kA/m (650 Oe) (reaffirm a national adoption INCITS/ISO/IEC 7811-8:2014 [2016])

INCITS/ISO/IEC 7811-9:2015 [R202x], Identification cards - Recording technique - Part 9: Tactile identifier mark (reaffirm a national adoption INCITS/ISO/IEC 7811-9:2015 [2016])

INCITS/ISO/IEC 10118-2:2010 [R202x], Information technology - Security techniques - Hash-functions - Part 2: Hash-functions using an n-bit block cipher (reaffirm a national adoption INCITS/ISO/IEC 10118-2:2010 [R2016])

INCITS/ISO/IEC 10373-2:2015 [R202x], Identification cards - Test methods - Part 2: Cards with magnetic stripes (reaffirm a national adoption INCITS/ISO/IEC 10373-2:2015 [2016])

ITI (INCITS) (InterNational Committee for Information Technology Standards)

700 K Street NW, Suite 600, Washington, DC 20001 p: (202) 737-8888 w: www.incits.org

INCITS/ISO/IEC 10373-1:2006 [R2016], Cards and security devices for personal identification - Test methods - Part 1: General characteristics (withdrawal of INCITS/ISO/IEC 10373-1:2006 [R2016])

INCITS/ISO/IEC 11179-5:2015 [R202x], Information technology - Metadata registries (MDR) - Part 5: Naming principles (reaffirm a national adoption INCITS/ISO/IEC 11179-5:2015 [2016])

INCITS/ISO/IEC 11694-3:2015 [R202x], Identification cards - Optical memory cards - Linear recording method - Part 3: Optical properties and characteristics (reaffirm a national adoption INCITS/ISO/IEC 11694-3:2015 [2016])

INCITS/ISO/IEC 11694-4:2008 [R202x], Identification cards - Optical memory cards - Linear recording method - Part 4: Logical data structures (reaffirm a national adoption INCITS/ISO/IEC 11694-4:2008 [2016])

INCITS/ISO/IEC 11694-5:2014 [R202x], Identification cards - Optical memory cards - Linear recording method - Part 5: Data format for information interchange for applications using ISO/IEC 11694-4 (reaffirm a national adoption INCITS/ISO/IEC 11694-5:2014 [2016])

INCITS/ISO/IEC 11694-6:2014 [R202x], Identification cards - Optical memory cards - Linear recording method - Part 6: Use of biometrics on an optical memory card (reaffirm a national adoption INCITS/ISO/IEC 11694-6:2014 [2016])

INCITS/ISO/IEC 11695-1:2015 [R202x], Identification cards - Optical memory cards - Holographic recording method - Part 1: Physical characteristics (reaffirm a national adoption INCITS/ISO/IEC 11695-1:2015 [2016])

INCITS/ISO/IEC 11695-2:2015 [R202x], Identification cards - Optical memory cards - Holographic recording method - Part 2: Dimensions and location of accessible optical area (reaffirm a national adoption INCITS/ISO/IEC 11695-2:2015 [2016])

INCITS/ISO/IEC 13818-4:2004/AM3:2009 [R202x], Information technology - Generic coding of moving pictures and associated audio information - Part 4: Conformance testing - Amendment 3: Level for 108050p/60p conformance testing (reaffirm a national adoption INCITS/ISO/IEC 13818-4:2004/AM3:2009 [R2016])

INCITS/ISO/IEC 13818-6:1998/AM 1:2000 [R202x], Information technology - Generic coding of moving pictures & associated audio info - Part 6: Extensions for DSM-CC - Amendment 1: Additions to support data broadcasting (reaffirm a national adoption INCITS/ISO/IEC 13818-6:1998/AM 1:2000 [R2016])

INCITS/ISO/IEC 14165-133:2010 [S202x], Information technology - Fibre Channel - Part 133: Switch Fabric-3 (FC-SW-3) (stabilized maintenance of INCITS/ISO/IEC 14165-133:2010 [R2016])

INCITS/ISO/IEC 14165-321:2009 [S202x], Information technology - Fibre Channel - Part 321: Audio-Video (FC-AV) (stabilized maintenance of INCITS/ISO/IEC 14165-321:2009 [R2016])

INCITS/ISO/IEC 14165-331:2007 [S202x], Information technology - Fibre Channel - Part 331: Virtual Interface (FC-VI) (stabilized maintenance of INCITS/ISO/IEC 14165-331:2007 [R2016])

INCITS/ISO/IEC 14495-1:1999 [R202x], Information technology - Lossless and near-lossless compression of continuous-tone still images: Baseline (reaffirm a national adoption INCITS/ISO/IEC 14495-1:1999 [R2016])

INCITS/ISO/IEC 14496-4:2004 [R202x], Information technology - Coding of audio-visual objects - Part 4: Conformance testing (reaffirm a national adoption INCITS/ISO/IEC 14496-4:2004 [R2016])

ITI (INCITS) (InterNational Committee for Information Technology Standards)

700 K Street NW, Suite 600, Washington, DC 20001 p: (202) 737-8888 w: www.incits.org

INCITS/ISO/IEC 14496-6:2000 [R202x], Information technology - Coding of audio-visual objects - Part 6: Delivery Multimedia Integration Framework (DMIF) (reaffirm a national adoption INCITS/ISO/IEC 14496-6:2000 [R2016])

INCITS/ISO/IEC 14496-20:2008/AM1:2009 [R202x], Information technology - Coding of audio-visual objects - Part 20: Lightweight Application Scene Representation (LAsER) and Simple Aggregation Format (SAF) - Amendment 1: Extensions to support SVGT1.2 (reaffirm a national adoption INCITS/ISO/IEC 14496-20:2008/AM1:2009 [R2016])

INCITS/ISO/IEC 14496-4:2004/AM 30:2009 [R202x], Information technology - Coding of audio-visual objects - Part 4: Conformance testing - Amendment 30: Conformance testing for new profiles for professional applications (reaffirm a national adoption INCITS/ISO/IEC 14496-4:2004/AM 30:2009 [R2016])

INCITS/ISO/IEC 14496-4:2004/AM 31:2009 [R202x], Information technology - Coding of audio-visual objects - Part 4: Conformance testing - Amendment 31: Conformance testing for SVC profiles (reaffirm a national adoption INCITS/ISO/IEC 14496-4:2004/AM 31:2009 [R2016])

INCITS/ISO/IEC 14496-4:2004/AM 35:2009 [R202x], Information technology - Coding of audio-visual objects - Part 4: Conformance testing - Amendment 35: Simple studio profile levels 5 and 6 conformance testing (reaffirm a national adoption INCITS/ISO/IEC 14496-4:2004/AM 35:2009 [R2016])

INCITS/ISO/IEC 14496-5:2001/AM 14:2009 [R202x], Information technology - Coding of audio-visual objects - Part 5: Reference software - Amendment 14: Open Font Format reference software (reaffirm a national adoption INCITS/ISO/IEC 14496-5:2001/AM 14:2009 [R2016])

INCITS/ISO/IEC 14496-5:2001/AM 19:2009 [R202x], Information technology - Coding of audio-visual objects - Part 5: Reference software - Amendment 19: Reference software for Scalable Video Coding (reaffirm a national adoption INCITS/ISO/IEC 14496-5:2001/AM 19:2009 [R2016])

INCITS/ISO/IEC 14496-5:2001/AM 20:2009 [R202x], Information technology - Coding of audio-visual objects - Part 5: Reference software - Amendment 20: MPEG-1 and -2 on MPEG-4 reference software and BSAC Extensions (reaffirm a national adoption INCITS/ISO/IEC 14496-5:2001/AM 20:2009 [R2016])

INCITS/ISO/IEC 14496-5:2001/AM 21:2009 [R202x], Information technology - Coding of audio-visual objects - Part 5: Reference software - Amendment 21: Frame-based Animated Mesh Compression reference software (reaffirm a national adoption INCITS/ISO/IEC 14496-5:2001/AM 21:2009 [R2016])

INCITS/ISO/IEC 14776-453:2009 [S202x], Information technology - Small computer system interface (SCSI) - Part 453: Primary commands-3 (SPC-3) (stabilized maintenance of INCITS/ISO/IEC 14776-453:2009 [R2016])

INCITS/ISO/IEC 15444-8:2007/AM 1:2008 [R202x], Information technology - JPEG 2000 image coding system: Secure JPEG 2000 - Amendment 1: File format security (reaffirm a national adoption INCITS/ISO/IEC 15444-8:2007/AM 1:2008 [R2016])

INCITS/ISO/IEC 15457-1:2008 [R202x], Identification cards - Thin flexible cards - Part 1: Physical characteristics (reaffirm a national adoption INCITS/ISO/IEC 15457-1:2008 [R2016])

INCITS/ISO/IEC 15457-3:2008 [R202x], Identification cards - Thin flexible cards - Part 3: Test methods (reaffirm a national adoption INCITS/ISO/IEC 15457-3:2008 [R2016])

ITI (INCITS) (InterNational Committee for Information Technology Standards)

700 K Street NW, Suite 600, Washington, DC 20001 p: (202) 737-8888 w: www.incits.org

INCITS/ISO/IEC 15938-3:2002/AM 3:2009 [R202x], Information technology - Multimedia content description interface - Part 3: Visual - Amendment 3: Image Signature Tools (reaffirm a national adoption INCITS/ISO/IEC 15938-3:2002/AM 3:2009 [R2016])

INCITS/ISO/IEC 19775-2:2015 [R202x], Information Technology - Computer Graphics, Image Processing and Environmental Data Representation - Extensible 3D (X3D) - Part 2: Scene Access Interface (SAI) (reaffirm a national adoption INCITS/ISO/IEC 19775-2:2015 [2016])

INCITS/ISO/IEC 19784-4:2011 [R202x], Information technology - Biometric application programming interface - Part 4: Biometric sensor function provider interface (reaffirm a national adoption INCITS/ISO/IEC 19784-4:2011 [R2016])

INCITS/ISO/IEC 19795-5:2011 [R202x], Information technology - Biometric performance testing and reporting - Part 5: Access control scenario and grading scheme (reaffirm a national adoption INCITS/ISO/IEC 19795-5:2011 [R2016])

INCITS/ISO/IEC 19795-7:2011 [R202x], Information technology - Biometric performance testing and reporting - Part 7: Testing of on-card biometric comparison algorithms (reaffirm a national adoption INCITS/ISO/IEC 19795-7:2011 [R2016])

INCITS/ISO/IEC 21000-8:2008/AM 1:2009 [R202x], Information technology - Multimedia framework (MPEG-21) - Part 8: Reference software - Amendment 1: Extract reference software (reaffirm a national adoption INCITS/ISO/IEC 21000-8:2008/AM 1:2009 [R2016])

INCITS/ISO/IEC 23000-4:2009 [R202x], Information technology - Multimedia application format (MPEG-A) - Part 4: Musical slide show application format (reaffirm a national adoption INCITS/ISO/IEC 23000-4:2009 [R2016])

INCITS/ISO/IEC 23000-3:2007/AM1:2009 [R202x], Information technology - Multimedia application format (MPEG-A) - Part 3: MPEG photo player application format - Amendment 1: Reference software for photo player MAF (reaffirm a national adoption INCITS/ISO/IEC 23000-3:2007/AM1:2009 [R2016])

INCITS/ISO/IEC 23000-4:2009/AM 1:2009 [R202x], Information technology - Multimedia application format (MPEG-A) - Part 4: Musical slide show application format - Amendment 1: Conformance and reference software for musical slide show application format (reaffirm a national adoption INCITS/ISO/IEC 23000-4:2009/AM 1:2009 [R2016])

INCITS/ISO/IEC 23000-7:2008/AM 1:2009 [R202x], Information technology - Multimedia application format (MPEG-A) - Part 7: Open access application format - Amendment 1: Conformance and reference software for open access application format (reaffirm a national adoption INCITS/ISO/IEC 23000-7:2008/AM 1:2009 [R2016])

INCITS/ISO/IEC 23004-8:2009 [R202x], Information technology - Multimedia Middleware - Part 8: Reference software (reaffirm a national adoption INCITS/ISO/IEC 23004-8:2009 [R2016])

INCITS/ISO/IEC 24709-3:2011 [R202x], Information technology - Conformance testing for the biometric application programming interface (BioAPI) - Part 3: Test assertions for BioAPI frameworks (reaffirm a national adoption INCITS/ISO/IEC 24709-3:2011 [R2016])

INCITS/ISO/IEC 24775-1:2014 [R202x], Information technology - Storage management - Part 1: Overview (reaffirm a national adoption INCITS/ISO/IEC 24775-1:2014 [2016])

INCITS/ISO/IEC 24775-2:2014 [R202x], Information technology - Storage management - Part 2: Common Architecture (reaffirm a national adoption INCITS/ISO/IEC 24775-2:2014 [2016])

ITI (INCITS) (InterNational Committee for Information Technology Standards)

700 K Street NW, Suite 600, Washington, DC 20001 p: (202) 737-8888 w: www.incits.org

INCITS/ISO/IEC 24775-3:2014 [R202x], Information technology - Storage management - Part 3: Common Profiles (reaffirm a national adoption INCITS/ISO/IEC 24775-3:2014 [2016])

INCITS/ISO/IEC 24775-4:2014 [R202x], Information technology - Storage management - Part 4: Block Devices (reaffirm a national adoption INCITS/ISO/IEC 24775-4:2014 [2016])

INCITS/ISO/IEC 24775-5:2014 [R202x], Information technology - Storage management - Part 5: File systems (reaffirm a national adoption INCITS/ISO/IEC 24775-5:2014 [2016])

INCITS/ISO/IEC 24775-6:2014 [R202x], Information technology - Storage management - Part 6: Fabric (reaffirm a national adoption INCITS/ISO/IEC 24775-6:2014 [2016])

INCITS/ISO/IEC 24775-7:2014 [R202x], Information technology - Storage management - Part 7: Host Elements (reaffirm a national adoption INCITS/ISO/IEC 24775-7:2014 [2016])

INCITS/ISO/IEC 24775-8:2014 [R202x], Information technology - Storage management - Part 8: Media Libraries (reaffirm a national adoption INCITS/ISO/IEC 24775-8:2014 [2016])

INCITS/ISO/IEC 29109-10:2010 [R202x], Information technology - Conformance testing methodology for biometric data interchange formats defined in ISO/IEC 19794 - Part 10: Hand geometry silhouette data (reaffirm a national adoption INCITS/ISO/IEC 29109-10:2010 [R2016])

INCITS/ISO/IEC 29120-1:2015 [R202x], Information technology - Machine readable test data for biometric testing and reporting - Part 1: Test reports (reaffirm a national adoption INCITS/ISO/IEC 29120-1:2015 [2016])

INCITS/ISO/IEC 29159-1:2010 [R202x], Information technology - Biometric calibration, augmentation, and fusion data - Part 1: Fusion information format (reaffirm a national adoption INCITS/ISO/IEC 29159-1:2010 [R2016])

INCITS/ISO/IEC 4909:2006 [R202x], Identification cards - Financial transaction cards - Magnetic stripe data content for track 3 (reaffirm a national adoption INCITS/ISO/IEC 4909:2006 [R2016])

INCITS/ISO/IEC 14750:1999 [R202x], Information Technology - Open Distributed Processing - Interface Definition Language (reaffirm a national adoption INCITS/ISO/IEC 14750:1999 [R2016])

INCITS/ISO/IEC 14752:2000 [R202x], Information Technology - Open Distributed Processing - Protocol Support for Computational Interactions (reaffirm a national adoption INCITS/ISO/IEC 14752:2000 [R2016])

INCITS/ISO/IEC 14753:1999 [R202x], Information Technology - Open Distributed Processing - Interface References and Binding (reaffirm a national adoption INCITS/ISO/IEC 14753:1999 [R2016])

INCITS/ISO/IEC 14769:2001 [R202x], Information Technology - Open Distributed Processing - Type Repository Function (reaffirm a national adoption INCITS/ISO/IEC 14769:2001 [R2016])

INCITS/ISO/IEC 14771:1999 [R202x], Information Technology - Open Distributed Processing - Naming Framework (reaffirm a national adoption INCITS/ISO/IEC 14771:1999 [R2016])

INCITS/ISO/IEC 16485:2000 [R202x], Information technology - Mixed Raster Content (MRC) (reaffirm a national adoption INCITS/ISO/IEC 16485:2000 [R2016])

INCITS/ISO/IEC 29183:2010 [R202x], Information technology - Office equipment - Method for measuring digital copying productivity of a single one-sided original (reaffirm a national adoption INCITS/ISO/IEC 29183:2010 [R2016])

ITI (INCITS) (InterNational Committee for Information Technology Standards)

700 K Street NW, Suite 600, Washington, DC 20001 p: (202) 737-8888 w: www.incits.org

INCITS/ISO/IEC 29197:2015 [R202x], Information technology - Evaluation methodology for environmental influence in biometric system performance (reaffirm a national adoption INCITS/ISO/IEC 29197:2015 [2016])

NSF (NSF International)

789 N. Dixboro Road, Ann Arbor, MI 48105-9723 p: (734) 827-3817 w: www.nsf.org
Allan Rose; arose@nsf.org

BSR/NSF 25-202x (i18r1), Vending Machines for Food and Beverages (revision of ANSI/NSF 25-2017)

NSF (NSF International)

789 N. Dixboro Road, Ann Arbor, MI 48105-9723 p: (734) 827-5643 w: www.nsf.org
Monica Leslie; mleslie@nsf.org

BSR/NSF 42-202x (i111r1), Drinking Water Treatment Units - Aesthetic Effects (revision of ANSI/NSF 42-2020)

BSR/NSF 53-202x (i129r1), Drinking Water Treatment Units - Health Effects (revision of ANSI/NSF 53-2020)

ROHVA (Recreational Off-Highway Vehicle Association)

2 Jenner Street, Suite 150, Irvine, CA 92618 p: (949) 255-2560 ext 3011
Ken Glaser; kglaser@rohva.org

BSR/ROHVA 1-202x, Recreational Off-Highway Vehicles (revision of ANSI/ROHVA 1-2016)

SVIA (Specialty Vehicle Institute of America)

2 Jenner, Suite 150, Irvine, CA 92618 p: (949) 727-3727
Ken Glaser; kglaser@svia.org

BSR/SVIA 1-202x, Four Wheel All-Terrain Vehicles (revision of ANSI/SVIA 1-2017)

TIA (Telecommunications Industry Association)

1320 North Courthouse Road, Suite 200, Arlington, VA 22201 p: (703) 907-7706 w: www.tiaonline.org
Teesha Jenkins; standards-process@tiaonline.org

BSR/TIA 1152-A-2016 (R202x), Requirements for Field Test Instruments and Measurements for Balanced Twisted-Pair Cabling (reaffirmation of ANSI/TIA 1152-A-2016)

Call for Members (ANS Consensus Bodies)

ANSI Accredited Standards Developer

INCITS Executive Board – ANSI Accredited SDO and US TAG to ISO/IEC JTC 1, Information Technology

The InterNational Committee for Information Technology Standards (INCITS), an ANSI accredited SDO, is the forum of choice for information technology developers, producers and users for the creation and maintenance of formal de jure IT standards. INCITS' mission is to promote the effective use of Information and Communication Technology through standardization in a way that balances the interests of all stakeholders and increases the global competitiveness of the member organizations.

The INCITS Executive Board serves as the consensus body with oversight of its 40+ Technical Committees. Additionally, the INCITS Executive Board has the international leadership role as the US Technical Advisory Group (TAG) to ISO/IEC JTC 1, Information Technology.

Membership in the INCITS Executive Board is open to all directly and materially affected parties in accordance with INCITS membership rules. To find out more about participating on the INCITS Executive Board, contact Jennifer Garner at jgarner@itic.org or visit <http://www.incits.org/participation/membership-info> for more information.

Membership in all interest categories is always welcome; however, the INCITS Executive Board seeks to broaden its membership base in the following categories:

- Service Providers
- Users
- Standards Development Organizations and Consortia
- Academic Institutions

ANSI Accredited Standards Developer

SCTE (Society of Cable Telecommunications Engineers)

SCTE, an ANSI-accredited SDO, is the primary organization for the creation and maintenance of standards for the cable telecommunications industry. SCTE's standards mission is to develop standards that meet the needs of cable system operators, content providers, network and customer premises equipment manufacturers, and all others who have an interest in the industry through a fair, balanced and transparent process.

SCTE is currently seeking to broaden the membership base of its ANS consensus bodies and is interested in new members in all membership categories to participate in new work in fiber-optic networks, advanced advertising, 3D television, and other important topics. Of particular interest is membership from the content (program and advertising) provider and user communities. Membership in the SCTE Standards Program is open to all directly and materially affected parties as defined in SCTE's membership rules and operating procedures. More information is available at www.scte.org or by e-mail from standards@scte.org.

Membership in the SCTE Standards Program is open to all directly and materially affected parties as defined in SCTE's membership rules and operating procedures. More information is available at www.scte.org or by e-mail from standards@scte.org.

Call for Members (ANS Consensus Bodies)

ANSI Accredited Standards Developers

CGA - Compressed Gas Association

CGA G-13 Interest categories sought

The **Compressed Gas Association, Inc. (CGA)** is actively seeking voting participation in the following standards development work and in the interest categories specified:

CGA G-13, *Storage and Handling of Silane and Silane Mixtures*

Interest categories sought:

- Distributor/retailer: Silane distributors and retailers;
- General interest: Industrial insurers, consultants, risk prevention and assessment companies, and those with a general interest in silane;
- Code Developers: Fire prevention officials, building and fire code developers; and
- Trade Association: Those representing a trade association with a direct and material interest in silane.

To apply or obtain additional information, please contact Kristy Mastromichalis at kmastromichalis@cganet.com, (www.cganet.com)

Call for Comment of ANS Limited Substantive Changes

ANSI Accredited Standards Developer

AIAA - American Institute of Aeronautics and Astronautics

ANSI/AIAA S-080A-2018 45-Day Comment Deadline: May 24, 2021

This Call for Comment of Limited Substantive Changes to the Approved American National Standard is available for review & comment until **May 24, 2021**.

ANSI/AIAA S-080A-2018

Space Systems - Metallic Pressure Vessels, Pressurized Structures, and Pressure Components
(new standard)

This standard establishes baseline requirements for the design, analysis, fabrication, test, operation, and maintenance of metallic pressure vessels, pressurized structures, batteries, heat pipes, and cryostats, dewars, sealed containers, accumulators, and pressure components such as lines, fittings, hoses, and bellows made of metals. These components are used for pressurized, hazardous, or nonhazardous liquid or gas storage in space systems including spacecraft and launch vehicles.

Obtain an electronic copy from: Nick Tongson; NickT@aiaa.org

Send comments (with optional copy to psa@ansi.org) to: Nick Tongson; NickT@aiaa.org

Single copy price: \$82.00

[Click here to view these changes in full](#)

Nick Tongson
Director of Standards
American Institute of Aeronautics and Astronautics (AIAA)
12700 Sunrise Valley Drive, Suite 200
Reston, VA 20191-5807
p: (703) 264-7515
e: NickT@aiaa.org

Call for Comment of ANS Limited Substantive Changes

ANSI Accredited Standards Developers

AIAA - American Institute of Aeronautics and Astronautics

ANSI/AIAA S-102.0.1-2019 30-Day Comment Deadline: May 9, 2021

This Call for Comment of Limited Substantive Changes to the Approved American National Standard is available for review & comment until **May 9, 2021**.

ANSI/AIAA S-102.0.1-2019

Capability-based mission assurance program – General requirements

(new standard)

This Standard provides requirements and guidance for implementing a capability-based Mission Assurance Program (MAP), that achieves system safety and mission success requirements through the integrated execution of Safety, RMA (Reliability, Maintainability, Availability, and Testability), and Quality Assurance best practices, which are prescriptively tailored to eliminate or control unacceptable technical risks throughout the system life cycle. The linkage of this Standard to other standards in the family of S-102 capability-based mission assurance standards is described, and an example set of data element descriptions (DEDs) that can be used to manage MAP data transfer and storage between and within organizations, is provided in Annex E.

Obtain an electronic copy from: Nick Tongson; NickT@aiaa.org

Send comments (with optional copy to psa@ansi.org) to: Nick Tongson; NickT@aiaa.org

Single copy price: \$110.00

[Click here to view these changes in full](#)

Nick Tongson

Director of Standards

American Institute of Aeronautics and Astronautics (AIAA)

12700 Sunrise Valley Drive, Suite 200

Reston, VA 20191-5807

p: (703) 264-7515

e: NickT@aiaa.org

American National Standards (ANS) Announcements

Corrections

NENA - National Emergency Number Association

BSR/NENA STA-010.3-202X Call for Comment Deadline is April 18, 2021

A call for comment on BSR/NENA STA-010.3-202X was mistakenly repeated in the April 2, 2021 Standards Action. This notice serves to clarify that the original and correct public review began March 19, 2021 with the comment deadline ending on April 18, 2021.

Order download & comment at:

https://dev.nena.org/higherlogic/ws/public/document?document_id=22277&wg_id=eca27a3d-a4c7-4d67-bb06-b3bb241df44e

Please direct inquiries to: Delaine Arnold p: (727) 312-3230, e: darnold@nena.org

Accreditation Announcements (Standards Developers)

Approval of Accreditation – ASD

SCS - SCS Standards Development

Effective April 2, 2021

ANSI's Executive Standards Council has approved **SCS - SCS Standards Development**, a new ANSI member in 2020, as an ANSI Accredited Standards Developer (ASD) under its proposed operating procedures for documenting consensus on SCS-sponsored American National Standards, effective **April 2, 2021**. For additional information, please contact: Ms. Diana Kirsanova Phillips, Director, SCS Standards Development, 2000 Powell Street, Suite 600, Emeryville, CA 96408 p: (510) 452-8030 e: DKirsanovaPhillips@scsglobalservices.com

Approval of Reaccreditation – ASD

AHRI - Air-Conditioning, Heating, and Refrigeration Institute

Effective October 11, 2016

The reaccreditation of **AHRI - Air-Conditioning, Heating, and Refrigeration Institute** has been approved at the direction of ANSI's Executive Standards Council, under its recently revised operating procedures for documenting consensus on AHRI-sponsored American National Standards, effective **October 11, 2016**. For additional information, please contact: Karl Best, Sr. Manager Standards, Air-Conditioning, Heating, and Refrigeration Institute (AHRI) - 2311 Wilson Boulevard, Suite 400, Arlington, VA 22201-3001 p: (703) 293-4887 e: kbest@ahrinet.org

Approval of Reaccreditation – ASD

NFPA - National Fire Protection Association

Effective April 2, 2021

ANSI's Executive Standards Council has reaccredited **NFPA - National Fire Protection Association** under its recently revised regulations for documenting consensus on NFPA-sponsored American National Standards, effective **April 2, 2021**. For additional information, please contact: Ms. Dawn Michele Bellis, Director, Standards Administration and NFPA Standards Council Secretary, NFPA, 1 Batterymarch Park, Quincy, MA 02169-7471; phone: 617.984.7210; email: DBellis@nfpa.org

Accreditation Announcements (Standards Developers)

Change of ASD Scope

TMS - The Masonry Society

Submit comments or questions by May 10, 2021

The Masonry Society (TMS), an ANS Member and ANSI-Accredited Standards Developer, has submitted the following revised ASD scope for informational purposes.

The Masonry Society (TMS) is a Not-for-Profit (501c(3)) educational society dedicated to the advancement of knowledge of masonry. TMS develops standards for the design, specification, construction, evaluation, repair, and renovation of masonry as sole sponsor or jointly with other organizations that are ANSI Accredited Standards Developers.

The former scope was:

The Masonry Society (TMS) is a Not-for-Profit (501c(3)) educational society dedicated to the advancement of knowledge of masonry. TMS develops standards for the design, specification, construction, evaluation, repair, and renovation of masonry. TMS has worked on the development of several standards with other organizations that are already ANSI Accredited Standards Developers, as described below for TMS Standards TMS 216, TMS 402 and TMS 602. TMS has been asked to take a more active role in the development of these standards by becoming the lead sponsoring organization (see attachment 2a). In addition, TMS wishes to develop several new standards for masonry. The scopes of these standards are described below.

· Masonry Standards Joint Committee's Building

Code Requirements for Masonry Structures (ACI 530/ASCE 5/TMS 402). Scope: This Code provides minimum requirements for the structural design and construction of masonry elements consisting of masonry bedded in mortar in any structure erected under the requirements of a legally adopted general building code of which this Code forms a part in areas without a legally adopted building code, this Code defines minimum acceptable standards of design and construction practice.

·Masonry Standards Joint Committee's Specification for Masonry Structures (ACI 530.1/ASCE 6/TMS 602) Scope: This Specification is written as a master specification and is required by the Building Code Requirements for Masonry Structures to control materials, labor and construction. It contains the minimum requirements to ensure the structural integrity of the masonry.

·Standard Method for Determining Fire Resistance of Concrete and Masonry Construction Assemblies (ANSI/ACI 216.1/TMS 0216) Scope: This standard describes acceptable methods for determining the fire resistance of concrete and masonry assemblies including walls, floors and roof slabs, beams, columns, lintels, and masonry fire protection for structural steel columns.

(Continued on Next Page)

Accreditation Announcements (Standards Developers)

Change of ASD Scope (Continued)

TMS - The Masonry Society

Submit comments or questions by May 10, 2021

- Standard Method for Determining the Sound Transmission Class Rating for Masonry Walls (TMS 302 -00) Scope: This Standard provides requirements for rating masonry walls for a sound transmission class (STC). This rating is for masonry walls in structures erected under the requirements of the legally adopted general building code of which this standard forms a part. In areas without a legally adopted building code, this Standard defines minimum acceptable methods to determine the STC rating of masonry wall assemblies. The STC rating of masonry walls is based on field or laboratory testing in accordance with standard test methods or is based on or determined by a calculation procedure.

·Standard for Masonry in Areas Subjected to High Winds (TMS xxx) Scope: This standard would present prescriptive methods to provide wind resistant designs and construction details for low-rise masonry structures. Requirements would satisfy the wind load requirements of Minimum Design Loads for Buildings and Other Structures (ASCE 7).

·Standard for the Design and Construction of Stone Cladding (TMS xxx) Scope: This standard would present design and construction requirements for stone units supported by metal anchors (often termed "dimension stone masonry" which are not laid in mortar).

·Standard Method for Strengthening, Repair and Rehabilitation of Existing Masonry (TMS xxx) Scope: This standard would provide guidance on the strengthening, repair, and rehabilitation of existing masonry since requirements from current codes and standards are often impractical and costly to apply to existing structures that were constructed under other codes and standards

Any comments or questions related to the revised scope should be submitted by May 10, 2021 to: Mr. Phil Samblanet, Executive Director, The Masonry Society, 105 South Sunset Street, Suite Q, Longmont, CO 80501; phone: (303) 939-9700; email: psamblanet@masonrysociety.org (please copy psa@ansi.org)

Public Review of Revised ASD Operating Procedures

CPLSO - CPLSO

Comment Deadline: May 10, 2021

The **CPLSO - CPLSO**, an ANSI Member and Accredited Standards Developer, has submitted revisions to its currently accredited operating procedures for documenting consensus on CPLSO-sponsored American National Standards, under which it was last reaccredited in 2018. As the revisions appear to be substantive in nature, the reaccreditation process is initiated.

To obtain a copy of the revised procedures or to offer comments, please contact: Hugh Pratt, Secretary, CPLSO (CPLSO) The Marchioness Building, Commercial Road, Bristol BS16TG, UK BS1 6TG p: (078) 796-2989 9 e: pratt.hugh@cplso.org

You may view/download a copy of the revisions during the public review period at the following URL:

<https://share.ansi.org/Shared%20Documents/Forms/AllItems.aspx?RootFolder=%2FShared%20Documents%2FStandards%20Activities%2FPublic%20Review%20and%20Comment%2FANS%20Accreditation%20Actions%2FApril%209%20%2D%20May%2010%2C%202021%20Public%20Review%20Period&InitialTabId=Ribbon%2EDocument&VisibilityContext=WSSTabPersistence>

Please submit any public comments on the revised procedures to CPLSO by **May 10, 2021**, with a copy to the ExSC Recording Secretary in ANSI's New York Office (thompso@ANSI.org).

Accreditation Announcements (Standards Developers)

Public Review of Revised ASD Operating Procedures

IIAR - International Institute of Ammonia Refrigeration

Comment Deadline: May 10, 2021

The **IIAR - International Institute of Ammonia Refrigeration**, an ANSI Member and Accredited Standards Developer, has submitted revisions to its currently accredited operating procedures for documenting consensus on IIAR-sponsored American National Standards, under which it was last reaccredited in 2017. As the revisions appear to be substantive in nature, the reaccreditation process is initiated.

To obtain a copy of the revised procedures or to offer comments, please contact: Eric Smith, Vice President and Technical Director, International Institute of Ammonia Refrigeration (IIAR) - 1001 N. Fairfax Street, Suite 503, Alexandria VA 22314-1797 p: (703) 312-4200 e: eric.smith@iiar.org

You may view/download a copy of the revisions during the public review period at the following URL:

<https://share.ansi.org/Shared%20Documents/Forms/AllItems.aspx?RootFolder=%2FShared%20Documents%2FStandards%20Activities%2FPublic%20Review%20and%20Comment%2FANS%20Accreditation%20Actions%2FApril%209%20%2D%20May%2010%2C%202021%20Public%20Review%20Period&InitialTabId=Ribbon%2EDocument&VisibilityContext=WSSTabPersistence>

Please submit any public comments on the revised procedures to IIAR by **May 10, 2021**, with a copy to the ExSC Recording Secretary in ANSI's New York Office (thomps@ANSI.org).

American National Standards (ANS) Process

Please visit ANSI's website (www.ansi.org) for resources that will help you to understand, administer and participate in the American National Standards (ANS) process. Documents posted at these links are updated periodically as new documents and guidance are developed, whenever ANS-related procedures are revised, and routinely with respect to lists of proposed and approved ANS. The main ANS-related link is www.ansi.org/asd and here are some direct links as well as highlights of information that is available:

Where to find Procedures, Guidance, Interpretations and More...

Please visit ANSI's website (www.ansi.org)

- ANSI Essential Requirements: Due process requirements for American National Standards (always current edition): www.ansi.org/essentialrequirements
- ANSI Standards Action (weekly public review announcements of proposed ANS and standards developer accreditation applications, listing of recently approved ANS, and proposed revisions to ANS-related procedures): www.ansi.org/standardsaction
- Accreditation information – for potential developers of American National Standards (ANS): www.ansi.org/sdoaccreditation
- ANS Procedures, ExSC Interpretations and Guidance (including a slide deck on how to participate in the ANS process and the BSR-9 form): www.ansi.org/asd
- Lists of ANSI-Accredited Standards Developers (ASDs), Proposed ANS and Approved ANS: www.ansi.org/asd
- American National Standards Key Steps: www.ansi.org/anskeysteps
- American National Standards Value: www.ansi.org/ansvalue
- ANS Web Forms for ANSI-Accredited Standards Developers - PINS, BSR8 | 108, BSR11, Technical Report: <https://www.ansi.org/portal/psawebforms/>
- Information about standards Incorporated by Reference (IBR): <https://ibr.ansi.org/>
- ANSI - Education and Training: www.standardslearn.org

If you have a question about the ANS process and cannot find the answer, please email us at: psa@ansi.org . Please also visit Standards Boost Business at www.standardsboostbusiness.org for resources about why standards matter, testimonials, case studies, FAQs and more.

If you are interested in purchasing an American National Standard, please visit <https://webstore.ansi.org>

American National Standards Under Continuous Maintenance

The ANSI Essential Requirements: Due Process Requirements for American National Standards provides two options for the maintenance of American National Standards (ANS): periodic maintenance (see clause 4.7.1) and continuous maintenance (see clause 4.7.2). Continuous maintenance is defined as follows:

The standard shall be maintained by an accredited standards developer. A documented program for periodic publication of revisions shall be established by the standards developer. Processing of these revisions shall be in accordance with these procedures. The published standard shall include a clear statement of the intent to consider requests for change and information on the submittal of such requests. Procedures shall be established for timely, documented consensus action on each request for change and no portion of the standard shall be excluded from the revision process. In the event that no revisions are issued for a period of four years, action to reaffirm or withdraw the standard shall be taken in accordance with the procedures contained in the ANSI Essential Requirements.

The Executive Standards Council (ExSC) has determined that for standards maintained under the Continuous Maintenance option, separate PINS announcements are not required. The following ANSI Accredited Standards Developers have formally registered standards under the Continuous Maintenance option.

-
- **AAMI (Association for the Advancement of Medical Instrumentation)**
 - **AARST (American Association of Radon Scientists and Technologists)**
 - **AGA (American Gas Association)**
 - **AGSC (Auto Glass Safety Council)**
 - **ASC X9 (Accredited Standards Committee X9, Incorporated)**
 - **ASHRAE (American Society of Heating, Refrigerating and Air-Conditioning Engineers, Inc.)**
 - **ASME (American Society of Mechanical Engineers)**
 - **ASTM (ASTM International)**
 - **GBI (Green Building Initiative)**
 - **HL7 (Health Level Seven)**
 - **IES (Illuminating Engineering Society)**
 - **ITI (InterNational Committee for Information Technology Standards)**
 - **MHI (Material Handling Industry)**
 - **NAHBRC (NAHB Research Center, Inc.)**
 - **NBBPVI (National Board of Boiler and Pressure Vessel Inspectors)**
 - **NCPDP (National Council for Prescription Drug Programs)**
 - **NEMA (National Electrical Manufacturers Association)**
 - **NISO (National Information Standards Organization)**
 - **NSF (NSF International)**
 - **PRCA (Professional Ropes Course Association)**
 - **RESNET (Residential Energy Services Network, Inc.)**
 - **SAE (SAE International)**
 - **TCNA (Tile Council of North America)**
 - **TIA (Telecommunications Industry Association)**
 - **UL (Underwriters Laboratories)**

To obtain additional information with regard to these standards, including contact information at the ANSI Accredited Standards Developer, please visit ANSI Online at www.ansi.org/asd, select "American National Standards Maintained Under Continuous Maintenance." Questions? psa@ansi.org.

ANSI-Accredited Standards Developers Contacts

The addresses listed in this section are to be used in conjunction with standards listed in PINS, Call for Comment and Final Actions. This section is a list of developers who have submitted standards for this issue of *Standards Action* – it is not intended to be a list of all ANSI-Accredited Standards Developers. Please send all address corrections to Standards Action Editor at standact@ansi.org.

AAFS

American Academy of Forensic Sciences
410 North 21st Street
Colorado Springs, CO 80904
e: tambrosius@aafs.org
p: (719) 453-1036
www.aafs.org

AAMI

Association for the Advancement of Medical Instrumentation
901 N. Glebe Road
Suite 300
Arlington, VA 22203
e: cellriott@aami.org
p: (703) 253-8261
www.aami.org

ANS

American Nuclear Society
555 North Kensington Avenue
La Grange Park, IL 60526
e: kmurdoch@ans.org
p: (708) 579-8268
www.ans.org

ASA (ASC S1)

Acoustical Society of America
1305 Walt Whitman Road
Suite 300
Melville, NY 11747
e: standards@acousticalsociety.org
p: (516) 576-2341
www.acousticalsociety.org

ASABE

American Society of Agricultural and Biological Engineers
2950 Niles Road
Saint Joseph, MI 49085
e: vangilder@asabe.org
p: (269) 932-7015
<https://www.asabe.org/>

ASHRAE

American Society of Heating, Refrigerating and Air-Conditioning Engineers, Inc.
180 Technology Parkway
Peachtree Corners, GA 30092
e: cking@ashrae.org
p: (404) 636-8400
www.ashrae.org

ASME

American Society of Mechanical Engineers
Two Park Avenue
M/S 6-2B
New York, NY 10016-5990
e: ansibox@asme.org
p: (212) 591-8489
www.asme.org

ASQ (ASC Z1)

American Society for Quality
600 N Plankinton Avenue
Milwaukee, WI 53203
e: standards@asq.org
p: (800) 248-1946
www.asq.org

ASTM

ASTM International
100 Barr Harbor Drive
West Conshohocken, PA 19428-2959
e: accreditation@astm.org
p: (610) 832-9744
www.astm.org

AWC

American Wood Council
222 Catocin Circle
Suite 201
Leesburg, VA 20175
e: bdouglas@awc.org
p: (202) 463-2770
www.awc.org

AWS

American Welding Society
8669 NW 36th Street
Suite 130
Miami, FL 33166-6672
e: kbulger@aws.org
p: (305) 443-9353
www.aws.org

AWWA

American Water Works Association
6666 W. Quincy Avenue
Denver, CO 80235
e: polson@awwa.org
p: (303) 347-6178
www.awwa.org

B11

B11 Standards, Inc.
P.O. Box 690905
Houston, TX 77269
e: cfelinski@b11standards.org
p: (832) 446-6999
<https://www.b11standards.org/>

CSA

CSA America Standards Inc.
8501 E. Pleasant Valley Road
Cleveland, OH 44131
e: ansi.contact@csagroup.org
p: (216) 524-4990
www.csagroup.org

ECIA

Electronic Components Industry
Association
13873 Park Center Road
Suite 315
Herndon, VA 20171
e: ldonohoe@ecianow.org
p: (571) 323-0294
www.ecianow.org

FCI

Fluid Controls Institute
1300 Sumner Avenue
Cleveland, OH 44115
e: fci@fluidcontrolsinstitute.org
p: (216) 241-7333
www.fluidcontrolsinstitute.org

FM

FM Approvals
1151 Boston-Providence Tpke
Norwood, MA 02062
e: patrick.byrne@fmaprovals.com
p: (781) 255-4846
www.fmglobal.com

FM

FM Approvals
1151 Boston-Providence Turnpike
Norwood, MA 02062
e: josephine.mahnken@fmaprovals.com
p: (781) 255-4813
www.fmglobal.com

HI

Hydraulic Institute
300 Interpace Parkway
Building A, 3rd Floor
Parsippany, NJ 07054
e: asisto@pumps.org
p: (862) 226-2055
www.pumps.org

HPS (ASC N13)

Health Physics Society
1313 Dolley Madison Blvd #402
McLean, VA 22101
e: nanjohns@verizon.net
p: (703) 790-1745
www.hps.org

IAPMO (ASSE Chapter)

ASSE International Chapter of IAPMO
18927 Hickory Creek Drive
Suite 220
Mokena, IL 60448
e: terry.burger@asse-plumbing.org
p: (909) 519-0740
www.asse-plumbing.org

IES

Illuminating Engineering Society
120 Wall Street, Floor 17
New York, NY 10005
e: pmcgillicuddy@ies.org
p: (917) 913-0027
www.ies.org

ITI (INCITS)

InterNational Committee for
Information Technology Standards
700 K Street NW
Suite 600
Washington, DC 20001
e: comments@standards.incits.org
p: (202) 737-8888
www.incits.org

NEMA (ASC C50)

National Electrical Manufacturers
Association
1300 N 17th Street
Suite 900
Rosslyn, VA 22209
e: mike.leibowitz@nema.org
p: (703) 841-3264
www.nema.org

NFPA

National Fire Protection Association
One Batterymarch Park
Quincy, MA 02169
e: dbellis@nfpa.org
p: (617) 984-7246
www.nfpa.org

NFPA

National Fire Protection Association
One Batterymarch Park
Quincy, MA 02269-9101
e: PFoley@nfpa.org
p: (617) 984-7248
www.nfpa.org

NSF

NSF International
789 N. Dixboro Road
Ann Arbor, MI 48105-9723
e: arose@nsf.org
p: (734) 827-3817
www.nsf.org

NSF

NSF International
789 N. Dixboro Road
Ann Arbor, MI 48105-9723
e: jsnider@nsf.org
p: (734) 418-6660
www.nsf.org

NSF

NSF International
789 N. Dixboro Road
Ann Arbor, MI 48105-9723
e: mleslie@nsf.org
p: (734) 827-5643
www.nsf.org

ROHVA

Recreational Off-Highway Vehicle
Association
2 Jenner Street
Suite 150
Irvine, CA 92618
e: kgjaser@rohva.org
p: (949) 255-2560

SCTE

Society of Cable Telecommunications
Engineers
140 Philips Rd
Exton, PA 19341
e: kcooney@scte.org
p: (800) 542-5040
www.scte.org

SVIA

Specialty Vehicle Institute of America
2 Jenner
Suite 150
Irvine, CA 92618
e: kgjaser@svia.org
p: (949) 727-3727

TCNA (ASC A108)

Tile Council of North America
100 Clemson Research Blvd.
Anderson, SC 29625
e: KSimpson@tileusa.com
p: (864) 646-8453
www.tcnatile.com

TIA

Telecommunications Industry
Association
1320 North Courthouse Road
Suite 200
Arlington, VA 22201
e: standards-process@tiaonline.org
p: (703) 907-7706
www.tiaonline.org

UL

Underwriters Laboratories
12 Laboratory Drive
P.O. Box 13995
Research Triangle Park, NC 27709
-3995
e: Doreen.Stocker@ul.org
p: (919) 549-1391
https://ul.org/

UL

Underwriters Laboratories
12 Laboratory Drive
Research Triangle Park, NC 27709
-3995
e: Jonette.A.Herman@ul.org
p: (919) 549-1479
https://ul.org/

UL

Underwriters Laboratories
12 Laboratory Drive
Research Triangle Park, NC 27709
-3995
e: Joshua.Johnson@ul.org
p: (919) 549-1053
https://ul.org/

UL

Underwriters Laboratories
12 Laboratory Drive
Research Triangle Park, NC 27709
-3995
e: kelly.smoke@ul.org
p: (919) 316-5147
https://ul.org/

UL

Underwriters Laboratories
12 Laboratory Drive
Research Triangle Park, NC 27709
-3995
e: Nicolette.A.Weeks@ul.org
p: (919) 549-0973
https://ul.org/

UL

Underwriters Laboratories
12 Laboratory Drive
Research Triangle Park, NC 27709
-3995
e: Vickie.T.Hinton@ul.org
p: (919) 549-1851
https://ul.org/

UL

Underwriters Laboratories
171 Nepean Street
Suite 400
Ottawa, ON K2P 0B4 Canada
e: laura.werner@ul.org
p: (613) 368-4417
https://ul.org/

UL

Underwriters Laboratories
333 Pfingsten Road
Northbrook, IL 60062
e: megan.monsen@ul.org
p: (847) 664-1292
https://ul.org/

UL

Underwriters Laboratories
333 Pfingsten Road
Northbrook, IL 60062-2096
e: Megan.M.VanHeirseele@ul.org
p: (847) 664-2881
https://ul.org/

UL

Underwriters Laboratories
333 Pfingsten Road
Northbrook, IL 60062-2096
e: Susan.P.Malohn@ul.org
p: (847) 664-1725
https://ul.org/

UL

Underwriters Laboratories
47173 Benicia Street
Fremont, CA 94538
e: Derrick.L.Martin@ul.org
p: (510) 319-4271
https://ul.org/

UL

Underwriters Laboratories
47173 Benicia Street
Fremont, CA 94538
e: Marcia.M.Kawate@ul.org
p: (510) 319-4259
<https://ul.org/>

UL

Underwriters Laboratories
47173 Benicia Street
Fremont, CA 94538
e: Paul.E.Lloret@ul.org
p: (510) 319-4269
<https://ul.org/>



ISO Draft International Standards

This section lists proposed standards that the International Organization for Standardization (ISO) is considering for approval. The proposals have received substantial support within the technical committees or subcommittees that developed them and are now being circulated to ISO members for comment and vote. Standards Action readers interested in reviewing and commenting on these documents should order copies from ANSI.

COMMENTS

Comments regarding ISO documents should be sent to ANSI's ISO Team (isot@ansi.org); comments on ISO documents must be submitted electronically in the approved ISO template and as a Word document as other formats will not be accepted. The final date for offering comments is listed after each draft.

ORDERING INSTRUCTIONS

ISO Drafts can be made available by contacting ANSI's Customer Service department. Please e-mail your request for an ISO Draft to Customer Service at sales@ansi.org. When making your request, please provide the date of the Standards Action issue in which the draft document you are requesting appears.

ROAD VEHICLES (TC 22)

ISO/DIS 16844-7, Road vehicles - Tachograph systems - Part 7: Parameters - 6/19/2021, \$134.00

SHIPS AND MARINE TECHNOLOGY (TC 8)

ISO/DIS 20672, Ships and marine technology - Rate of turn indicators - 6/24/2021, \$40.00

ISO/DIS 20673, Ships and marine technology - Electric rudder angle indicators - 6/24/2021, \$40.00

ISO/DIS 22555, Ships and marine technology - Propeller pitch indicators - 6/24/2021, \$40.00

TRACTORS AND MACHINERY FOR AGRICULTURE AND FORESTRY (TC 23)

ISO/DIS 15639-2, Radio frequency identification of animals - Standardization of injection sites for different animal species - Part 2: Equine (horses, donkeys, and zebras) - 6/19/2021, \$40.00

WATER QUALITY (TC 147)

ISO/DIS 13165-2, Water quality - Radium-226 - Part 2: Test method using emanometry - 6/21/2021, \$71.00

ISO/IEC JTC 1, Information Technology

ISO/IEC DIS 23751, Information technology - Cloud computing and distributed platforms - Data sharing agreement (DSA) framework - 6/20/2021, \$93.00



Newly Published ISO & IEC Standards

Listed here are new and revised standards recently approved and promulgated by ISO - the International Organization for Standardization – and IEC – the International Electrotechnical Commission. Most are available at the ANSI Electronic Standards Store (ESS) at www.ansi.org. All paper copies are available from Standards resellers (<http://webstore.ansi.org/faq.aspx#resellers>).

ISO Standards

AGRICULTURAL FOOD PRODUCTS (TC 34)

[ISO 15216-1/Amd1:2021](#), Microbiology of the food chain - Horizontal method for determination of hepatitis A virus and norovirus using real-time RT-PCR - Part 1: Method for quantification - Amendment 1, \$20.00

[ISO 771:2021](#), Oilseed meals - Determination of moisture and volatile matter content, \$73.00

[ISO 22994:2021](#), Coffee extracts - Determination of the dry matter content of coffee extracts - Sea sand method of liquid or pasty coffee extracts, \$48.00

AIRCRAFT AND SPACE VEHICLES (TC 20)

[ISO 3185:2021](#), Aerospace - Bolts, normal bihexagonal head, normal shank, short or medium length MJ threads, metallic material, coated or uncoated, strength classes less than or equal to 1 100 MPa - Dimensions, \$48.00

BUILDING CONSTRUCTION (TC 59)

[ISO 6927:2021](#), Building and civil engineering sealants - Vocabulary, \$48.00

HEALTH INFORMATICS (TC 215)

[ISO 23903:2021](#), Health informatics - Interoperability and integration reference architecture - Model and framework, \$149.00

[ISO 81001-1:2021](#), Health software and health IT systems safety, effectiveness and security - Part 1: Principles and concepts, \$225.00

PETROLEUM PRODUCTS AND LUBRICANTS (TC 28)

[ISO 13736:2021](#), Determination of flash point - Abel closed-cup method, \$149.00

PLASTICS (TC 61)

[ISO 844:2021](#), Rigid cellular plastics - Determination of compression properties, \$111.00

PLASTICS PIPES, FITTINGS AND VALVES FOR THE TRANSPORT OF FLUIDS (TC 138)

[ISO 10952:2021](#), Glass-reinforced thermosetting plastics (GRP) pipes and fittings - Determination of the resistance to chemical attack for the inside of a section in a deflected condition, \$73.00

[ISO 11298-4:2021](#), Plastics piping systems for renovation of underground water supply networks - Part 4: Lining with cured-in-place pipes, \$200.00

REFRIGERATION (TC 86)

[ISO 22042:2021](#), Blast chiller and freezer cabinets for professional use - Classification, requirements and test conditions, \$73.00

RUBBER AND RUBBER PRODUCTS (TC 45)

[ISO 23075:2021](#), Vulcanized rubbers - Determination of antidegradants by high-performance liquid chromatography, \$111.00

SHIPS AND MARINE TECHNOLOGY (TC 8)

[ISO 23577:2021](#), Ships and marine technology - Cargo securing systems on ships - Vocabulary, \$48.00

SURFACE CHEMICAL ANALYSIS (TC 201)

[ISO 20579-3:2021](#), Surface chemical analysis - Sample handling, preparation and mounting - Part 3: Biomaterials, \$73.00

TERMINOLOGY (PRINCIPLES AND COORDINATION) (TC 37)

[ISO 24613-3:2021](#), Language resource management - Lexical markup framework (LMF) - Part 3: Etymological extension, \$149.00

IEC Technical Reports

NANOTECHNOLOGIES (TC 229)

[IEC/TR 63258:2021](#), Nanotechnologies - A guideline for ellipsometry application to evaluate the thickness of nanoscale films, FREE

ISO Technical Reports

HEALTH INFORMATICS (TC 215)

[ISO/TR 21332:2021](#), Health informatics - Cloud computing considerations for the security and privacy of health information systems, \$225.00

ISO Technical Specifications

ROAD VEHICLES (TC 22)

[ISO/TS 16951:2021](#), Road vehicles - Ergonomic aspects of transport information and control systems (TICS) - Procedures for determining priority of on-board messages presented to drivers, \$175.00

SMALL CRAFT (TC 188)

[ISO/TS 23625:2021](#), Small craft - Lithium-ion batteries, \$73.00

ISO/IEC JTC 1, Information Technology

[ISO/IEC 18598/Amd1:2021](#), Information technology - Automated infrastructure management (AIM) systems - Requirements, data exchange and applications - Amendment 1, FREE

[ISO/IEC 5055:2021](#), Information technology - Software measurement - Software quality measurement - Automated source code quality measures, \$250.00

[ISO/IEC 24824-4:2021](#), Information technology - Generic applications of ASN.1 - Part 4: Cryptographic message syntax, \$250.00

[ISO/IEC TS 23078-3:2021](#), Information technology - Specification of DRM technology for digital publications - Part 3: Device key-based protection, \$175.00

IEC Standards

ELECTRICAL APPARATUS FOR EXPLOSIVE ATMOSPHERES (TC 31)

[IEC 60079-10-1 Ed. 3.0 en cor.1:2021](#), Corrigendum 1 - Explosive atmospheres - Part 10-1: Classification of areas - Explosive gas atmospheres, \$0.00

FIBRE OPTICS (TC 86)

[IEC 62148-15 Ed. 3.0 b:2021](#), Fibre optic active components and devices - Package and interface standards - Part 15: Discrete vertical cavity surface emitting laser packages, \$183.00

[S+ IEC 62148-15 Ed. 3.0 en:2021 \(Redline version\)](#), Fibre optic active components and devices - Package and interface standards - Part 15: Discrete vertical cavity surface emitting laser packages, \$239.00

SOLAR PHOTOVOLTAIC ENERGY SYSTEMS (TC 82)

[IEC 62920 Amd.1 Ed. 1.0 b:2021](#), Amendment 1 - Photovoltaic power generating systems - EMC requirements and test methods for power conversion equipment, \$51.00

[IEC 62920 Ed. 1.1 b:2021](#), Photovoltaic power generating systems - EMC requirements and test methods for power conversion equipment, \$506.00

SURFACE MOUNTING TECHNOLOGY (TC 91)

[IEC 60068-2-20 Ed. 6.0 b:2021](#), Environmental testing - Part 2-20: Tests - Test Ta and Tb: Test methods for solderability and resistance to soldering heat of devices with leads, \$133.00

[S+ IEC 60068-2-20 Ed. 6.0 en:2021 \(Redline version\)](#), Environmental testing - Part 2-20: Tests - Test Ta and Tb: Test methods for solderability and resistance to soldering heat of devices with leads, \$239.00

TERMINOLOGY (TC 1)

[IEC 60050-431 Amd.1 Ed. 1.0 b:2021](#), Amendment 1 - International Electrotechnical Vocabulary (IEV) - Part 431: Transducers, \$13.00

[IEC 60050-712 Amd.1 Ed. 1.0 b:2021](#), Amendment 1 - International Electrotechnical Vocabulary (IEV) - Part 712: Antennas, \$13.00

[IEC 60050-726 Amd.6 Ed. 1.0 b:2021](#), Amendment 6 - International Electrotechnical Vocabulary (IEV) - Part 726: Transmission lines and waveguides, \$13.00

[IEC 60050-731 Amd.6 Ed. 1.0 b:2021](#), Amendment 6 - International Electrotechnical Vocabulary (IEV) - Part 731: Optical fibre communication, \$13.00

[IEC 60050-732 Amd.3 Ed. 1.0 b:2021](#), Amendment 3 - International Electrotechnical Vocabulary (IEV) - Part 732: Computer network technology, \$13.00

[IEC 60050-802 Amd.1 Ed. 1.0 b:2021](#), Amendment 1 - International Electrotechnical Vocabulary (IEV) - Part 802: Ultrasonics, \$13.00

[IEC 60050-815 Amd.3 Ed. 2.0 b:2021](#), Amendment 3 - International Electrotechnical Vocabulary (IEV) - Part 815: Superconductivity, \$13.00

[IEC 60050-841 Amd.1 Ed. 2.0 b:2021](#), Amendment 1 - International Electrotechnical Vocabulary (IEV) - Part 841: Industrial electroheat, \$13.00

International Organization for Standardization (ISO)

ISO Proposal for a New Field of ISO Technical Activity

Deoxidizers and Desiccants

Comment Deadline: June 18, 2021

SAC, the ISO member body for China, has submitted to ISO a proposal for a new field of ISO technical activity on Deoxidizers and Desiccants, with the following scope statement:

Standardization in the field of deoxidizers and desiccants, including terminology, categories, specifications, control and management of production processes, and testing methods of the quality and safety indexes.

Excluded:

1. *Requirements of the outer package of products covered by ISO/TC122*

Anyone wishing to review the proposal can request a copy by contacting ANSI's ISO Team (isot@ansi.org), with a submission of comments to Steve Cornish (scornish@ansi.org) by close of business on Friday, June 18, 2021.

ISO Proposal for a New Field of ISO Technical Activity

Roofing and Waterproofing Building Materials

Comment Deadline: April 23, 2021

GOST R, the ISO member body for Russia, has submitted to ISO a proposal for a new field of ISO technical activity on Roofing and waterproofing building materials, with the following scope statement:

Standardization of materials and components used for roofs design and construction processes, as well as materials used for waterproofing in construction.

Anyone wishing to review the proposal can request a copy by contacting ANSI's ISO Team (sot@ansi.org), with a submission of comments to Steve Cornish (scornish@ansi.org) by close of business on April 23, 2021.

Registration of Organization Names in the United States

The Procedures for Registration of Organization Names in the United States of America (document ISSB 989) require that alphanumeric organization names be subject to a 90-day Public Review period prior to registration. For further information, please contact the Registration Coordinator at (212) 642-4975.

When organization names are submitted to ANSI for registration, they will be listed here alphanumerically.

Alphanumeric names appearing for the first time are printed in bold type. Names with confidential contact information, as requested by the organization, list only public review dates.

Public Review

NOTE: Challenged alphanumeric names are underlined. The Procedures for Registration provide for a challenge process, which follows in brief. For complete details, see Section 6.4 of the Procedures.

A challenge is initiated when a letter from an interested entity is received by the Registration Coordinator. The letter shall identify the alphanumeric organization name being challenged and state the rationale supporting the challenge. A challenge fee shall accompany the letter. After receipt of the challenge, the alphanumeric organization name shall be marked as challenged in the Public Review list. The Registration Coordinator shall take no further action to register the challenged name until the challenge is resolved among the disputing parties.

Proposed Foreign Government Regulations

Call for Comment

U.S. manufacturers, exporters, regulatory agencies and standards developing organizations may be interested in proposed foreign technical regulations notified by Member countries of the World Trade Organization (WTO). In accordance with the WTO Agreement on Technical Barriers to Trade (TBT Agreement), Members are required to notify proposed technical regulations that may significantly affect trade to the WTO Secretariat in Geneva, Switzerland. In turn the Secretariat issues and makes available these notifications. The purpose of the notification requirement is to provide global trading partners with an opportunity to review and comment on the regulations before they become final.

The USA Inquiry Point for the WTO TBT Agreement is located at the National Institute of Standards and Technology (NIST) in the Standards Coordination Office (SCO). The Inquiry Point distributes the notified proposed foreign technical regulations (notifications) and makes the associated full-texts available to U.S. stakeholders via its online service, Notify U.S. Interested U.S. parties can register with Notify U.S. to receive e-mail alerts when notifications are added from countries and industry sectors of interest to them. To register for Notify U.S., please visit: <http://www.nist.gov/notifyus/>

The USA WTO TBT Inquiry Point is the official channel for distributing U.S. comments to the network of WTO TBT Enquiry Points around the world. U.S. business contacts interested in commenting on the notifications are asked to review the comment guidance available on Notify U.S. at: <https://tsapps.nist.gov/notifyus/data/guidance/guidance.cfm> prior to submitting comments.

For further information about the USA TBT Inquiry Point, please visit: <https://www.nist.gov/standardsgov/what-we-do/trade-regulatory-programs/usa-wto-tbt-inquiry-point> Contact the USA TBT Inquiry Point at (301) 975-2918; F: (301) 926-1559; E: usatbtep@nist.gov or notifyus@nist.gov.



**BSR/ASHRAE Addendum a to
ANSI/ASHRAE Standard 41.10-2020**

Public Review Draft

**Proposed Addendum a to
Standard 41.10-2020, Standard
Methods for Refrigerant Mass Flow
Rate Measurements Using
Flowmeters**

**First Public Review (April 2021)
(Draft shows Proposed Changes to Current Standard)**

This draft has been recommended for public review by the responsible project committee. To submit a comment on this proposed standard, go to the ASHRAE website at www.ashrae.org/standards-research--technology/public-review-drafts and access the online comment database. The draft is subject to modification until it is approved for publication by the Board of Directors and ANSI. Until this time, the current edition of the standard (as modified by any published addenda on the ASHRAE website) remains in effect. The current edition of any standard may be purchased from the ASHRAE Online Store at www.ashrae.org/bookstore or by calling 404-636-8400 or 1-800-727-4723 (for orders in the U.S. or Canada).

This standard is under continuous maintenance. To propose a change to the current standard, use the change submittal form available on the ASHRAE website, www.ashrae.org.

The appearance of any technical data or editorial material in this public review document does not constitute endorsement, warranty, or guaranty by ASHRAE of any product, service, process, procedure, or design, and ASHRAE expressly disclaims such.

© 2021 ASHRAE. This draft is covered under ASHRAE copyright. Permission to reproduce or redistribute all or any part of this document must be obtained from the ASHRAE Manager of Standards, 1791 Tullie Circle, NE, Atlanta, GA 30329. Phone: 404-636-8400, Ext. 1125. Fax: 404-321-5478. E-mail: standards.section@ashrae.org.

ASHRAE, 180 Technology Parkway, Peachtree Corners GA 30092

BSR/ASHRAE Addendum a to ANSI/ASHRAE Standard 41.10-2020, *Standard Methods for Refrigerant Mass Flow Rate Measurements Using Flowmeters*
First Public Review Draft

This addendum makes proposed changes to the current standard. These changes are indicated in the text by underlining (for additions) and strikethrough (for deletions).

Section 3, Definitions: Add the new definition below for clarification.

steady-state criteria: the criteria that establish negligible change of refrigerant mass flow rate with time.

Section 5, Test Plan: Revise as shown below for clarification.

5.1 Test Plan. A test plan shall specify the refrigerant mass flow rate measurement system accuracy ~~and the test points to be performed.~~ Additionally, the test plan shall include the test points, targeted set points, and corresponding operating tolerances to be performed. The test plan shall be one of the following documents:

- a. A document provided by the person or the organization that authorized the tests and calculations to be performed.
- b. A method of test standard.
- c. A rating standard.
- d. A regulation or code.
- e. Any combination of items a. through d.

Section 7.4.2, Nozzle Mass Flow Rate Methods: Correct Equation 7-5 as shown below.

The dimensionless expansion factor, ε , for a long radius nozzle⁸ shall be obtained from Equation 7-5.

$$\varepsilon = \left[r^{\frac{2}{\gamma}} \left(\frac{\gamma}{\gamma-1} \right) \left(\frac{1-r^{\frac{\gamma-1}{\gamma}}}{1-r} \right) \left(\frac{1-\beta^4}{1-\beta^4 r^{\frac{2}{\gamma}}} \right) \right]^{1/2} \quad (7-5)$$

where

r = absolute pressure ratio = $\frac{(p_2)}{(p_1)} = \left[\frac{p_2}{(p_1 - \Delta p)} \right]$, dimensionless

γ = ratio of specific heat at constant pressure to specific heat at constant volume, dimensionless

Tracking number 25i18r1
© 2021 NSF International

Revision to NSF/ANSI 25-2017
Issue 18 Revision 1 (March 2021)

Not for publication. This document is part of the NSF International standard development process. This draft text is for circulation for review and/or approval by an NSF Standards Committee and has not been published or otherwise officially adopted. All rights reserved. This document may be reproduced for informational purposes only.

[Note – the recommended changes to the standard which include the current text of the relevant section(s) indicate deletions by use of ~~strikeout~~ and additions by grey highlighting. Rationale statements are in *red italics* and only used to add clarity; these statements will NOT be in the finished publication.]

NSF/ANSI Standard
for Food Equipment –

Vending Machines for Food and Beverages

•

5 Design and construction

•

5.1.2 Vending machines and components shall be designed so that food and ingredients may be added and unit servings of bulk or packaged foods may be dispensed or removed in a sanitary manner.

5.1.2.1 Time/temperature control for safety food products dispensed through a vending machine shall be in the original package.

Rationale: the design for vending machines has changed over time, with some machines designed to have a tank or reservoir which is filled by pouring TCS bulk food product from the original container into the temperature-controlled reservoir of a machine. The proposed language aligns the requirements of Standard 25 with the FDA Food Code for those vending machines which dispense bulk TCS food.

UL 1450

April 9, 2021

Standard: UL 1450 Ed. 4**Standard Title:** Standard for Safety for Motor-Operated Air Compressors, Vacuum Pumps, and Painting Equipment**Date of Proposal:** April 9, 2021**STP Ballots & Comments Due:** May 10, 2021

1. Revision of Cord Tag Requirements

PROPOSAL

56 Permanence of Marking Tests

56.1 A marking that is required to be permanent shall be molded, die-stamped, paint-stenciled, stamped or etched metal that is permanently secured, or indelibly stamped lettering on a pressure-sensitive label that complies with the requirements in the Standard for Marking and Labeling Systems, UL 969. Ordinary usage, handling, storage, and the like of a product are considered in the determination of the permanence of a marking.

56.2 In addition to complying with the requirement in 56.1 and, after being tested as described in 56.6, a tag used for a cautionary marking in accordance with 65.5 is considered to be permanently affixed to a power-supply cord or hose if there is no:

- a) Tearing at any point for more than 1/16 in (1.6 mm),
- b) Movement of the tag more than 1/2 in (12.7 mm) along the length of the power-supply cord or hose,

Exception: A tag applied to a hose may move more than 1/2 in provided a fitting on each end of the hose prevents the tag from sliding off.

- c) Shrinkage, wrinkling, cracking, or other deformation that renders the marking illegible, or
- d) Visible curling or loosening around the edges of a tag with an adhesive back.

Exception: A tag used for a cautionary marking complying with the applicable requirements in the Standard for Marking and Labeling Systems – Flag Labels, Flag Tags, Wrap-Around Labels and Related Products, ANSI/CAN/UL 969A, is not required to comply with this requirement. With respect to a tag applied to a hose, the exception in b) above is also applicable.

UL 1450

April 9, 2021

2. Update of Standard Reference For Ultraviolet Light Test

PROPOSAL

SA10.9 Ultraviolet-light test

SA10.9.1 A hose employed on a unit not marked in accordance with 65.13, or a hose evaluated separately that is not marked in accordance with SA12.3 shall be subjected to the test specified in the Standard for Rubber and Plastics Hoses – Methods of exposure to laboratory light sources — Determination of changes in colour, appearance and other physical properties ~~Determination of Ultra-Violet Resistance Under Static Conditions~~, ISO ~~300138580~~. As a result of the test, the covers of the hose specimens shall not show signs of crazing or cracking.

SA10.9.2 Two 8-in (203-mm) lengths of hose are to be subjected to the test described in ISO ~~300138580~~.

Copyright © 2021 Underwriters Laboratories Inc.

UL copyrighted material. Not authorized for further reproduction without prior permission from UL.

BSR/UL 5800, Standard for Safety for Battery Fire Containment Products

1. Editorial Revisions to Clauses 4.2, 8.2.3, 8.2.5, 8.2.6, 8.2.10, Figure 8.1, and Figure 8.2

4.2 The following publications are referenced in this Standard:

UL 94, Tests for Flammability of Plastic Materials for Parts in Devices and Appliances

UL 969, Marking and Labeling Systems

UL 1439, Test for Sharpness of Edges on Equipment

UL 1479, Fire Tests of Penetration Firestops

C22.2 No. 0.15, Adhesive Labels

EN 12477, Protective gloves for welders

NFPA 1971, Standard on Protective Ensembles for Structural Fire Fighting and Proximity Fire Fighting

8.2.3 Cells utilized in the fuel load/package shall be lithium ion 18650 format (nominal 18 mm diameter, 65 mm length) with capacity of 3400 ± 100 mAh. All cells shall be charged to 100% state of charge (SOC). Cells shall not be electrically connected. The rated capacity of each cell shall be verified prior to testing. See Annex B, Cell Capacity Check Procedure.

8.2.5 One flexible film heater having a rating of 10 W/in^2 and covering a majority of the cell surface shall be wrapped around one cell located centrally in the middle or bottom row, as highlighted in Figure 8.3. One Type K thermocouple, 0.21 mm^2 (24 AWG) or 0.05 mm^2 (30 AWG), shall be attached to the cell surface using polyimide tape, or equivalent, to monitor temperature on the initiating cell.

8.2.6 One Type K thermocouple, 0.21 mm^2 (24 AWG) or 0.05 mm^2 (30 AWG), shall be attached to the cell surface using polyimide tape, or equivalent, on at least one cell at each end of the fuel load/package to monitor for cell-to-cell propagation.

8.2.10 The 0.21 mm^2 (24 AWG) or 0.05 mm^2 (30 AWG) Type-K exposed junction thermocouples shall be adhered with polyimide tape, epoxy, room-temperature vulcanizing silicone, or equivalent, to the containment product's surface in locations evenly spaced, with a density not less than 1 thermocouple per 232.3 cm^2 (36 in^2) of surface area. At least one thermocouple shall be placed on both the containment product's exterior surface directly above and below the location of the fuel load/package within the containment product. Additional thermocouples shall be placed in other locations as determined appropriate, such as dedicated vents, openings, handles, latches, or other non-uniform areas.

**Figure 8.1
Test setup**

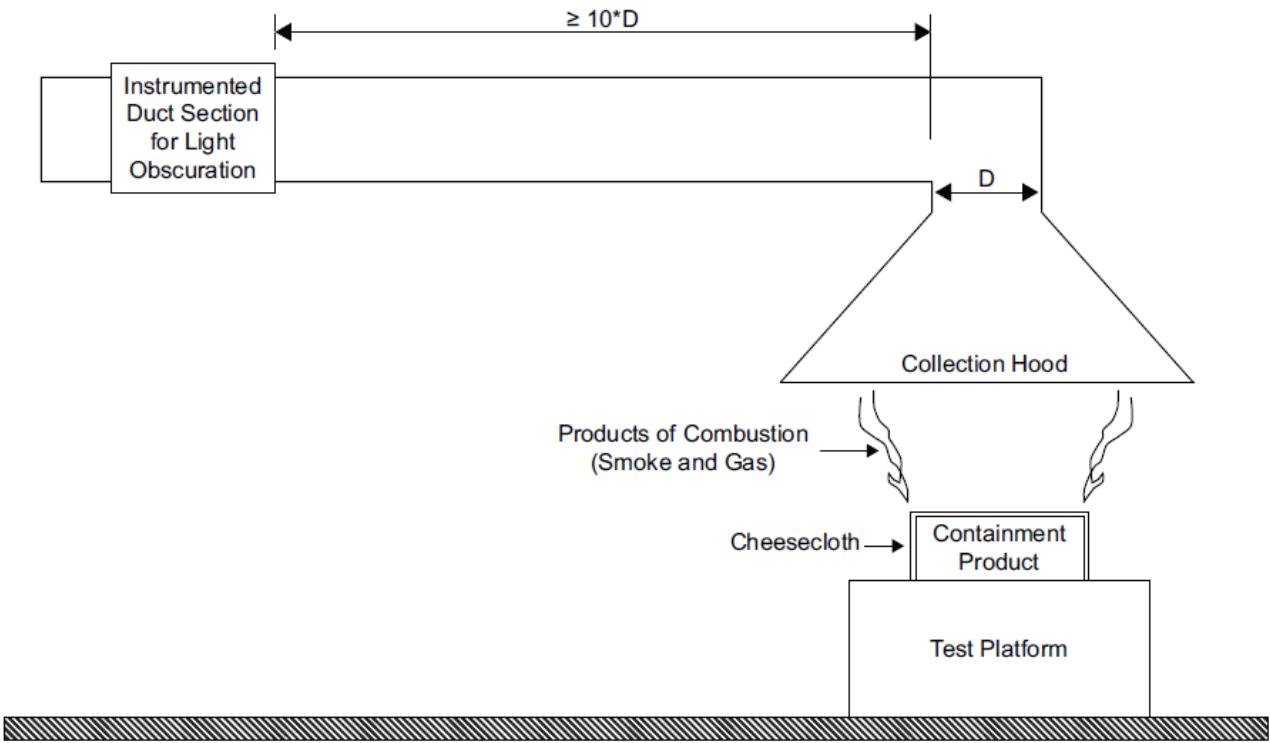

su3764

Key
D = diameter of the duct

UL copyrighted material. Not authorized for further distribution.

Figure 8.2
Example of bidirectional probe

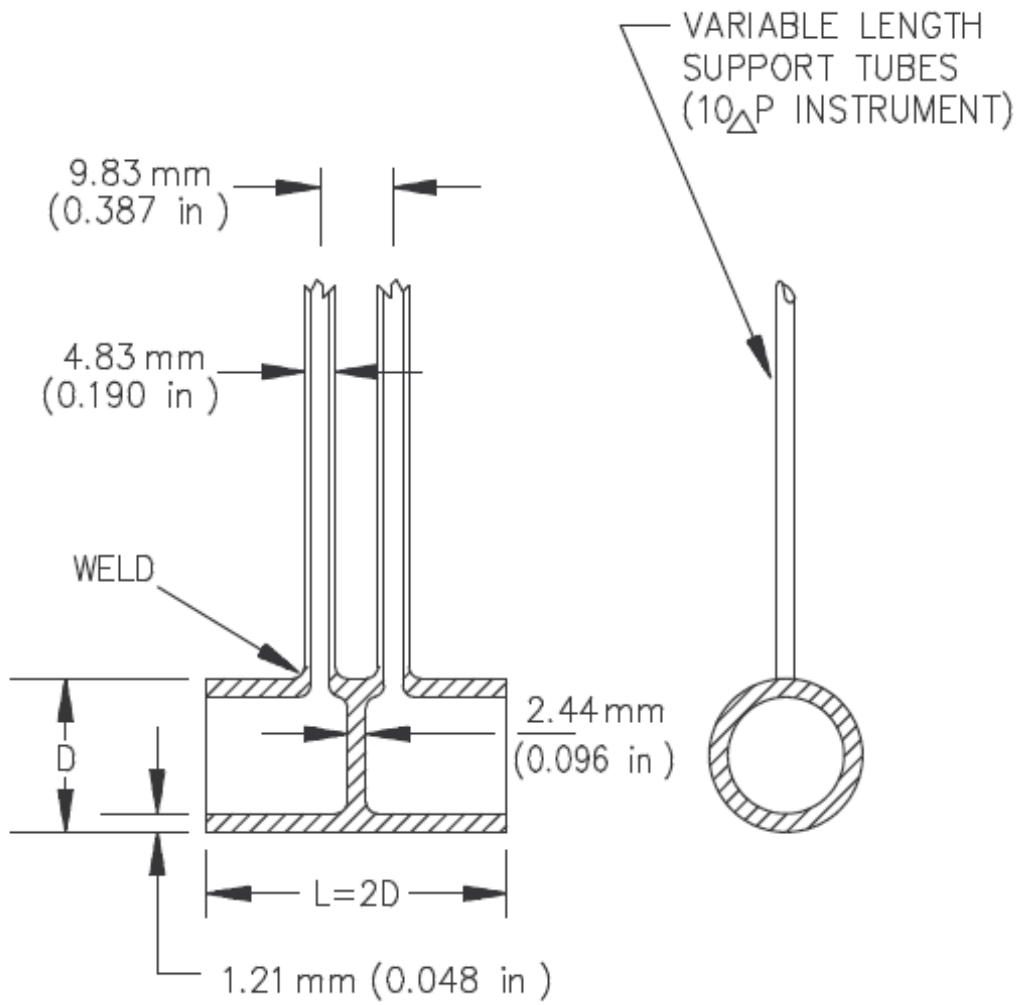

Version from UL.

s3594g

Key

D = probe outside diameter

L = probe length

UL copyright material.

ANSI/AIAA S-080A-2018

Space Systems – Metallic Pressure Vessels, Pressurized Structures, and Pressure Components

Excerpted Text for ANSI Public Review

1.3.3 Manufacturer

The manufacturer is responsible for the overall design and fabrication of the metallic pressurized hardware, including analysis and testing. This process involves procuring materials, constructing, testing, and certifying that the metallic pressurized hardware is in compliance with the requirements of this standard as tailored by the owner and the procuring authority. The manufacturer is also responsible for developing the documentation required throughout the design and manufacturing of the metallic pressurized hardware.

2 Tailoring

The requirements defined in this Standard may be tailored to match the actual requirements of the particular program or project. Tailoring of requirements shall be undertaken in agreement with the owner and procuring authority (as appropriate).

NOTE Tailoring is a process by which individual requirements or specifications, standards, and related documents are evaluated and made applicable to a specific program or project by selection, and in some cases, modification, and addition, or deletion of requirements in the standards. Such exceptions or modifications should be expressly delineated in applicable purchase orders, contracts, and other technical documents.

4.1 Acronyms and Abbreviated Terms

<i>a</i>	minor semi-axis of an elliptical flaw (crack)
<i>c</i>	major semi-axis of an elliptical flaw (crack)
da/dN	fatigue crack growth rate in the “a” direction
dc/dN	fatigue crack growth rate in the “c” direction

5.1 System Analysis

A detailed system analysis shall be performed for the aerospace system containing the pressurized hardware to determine the operational envelope, design and verification approach, and reliability requirements for the pressurized hardware.

5.1.3 Maximum Expected Operating Pressure

The pressure system shall be analyzed to determine the maximum expected operating pressure (MEOP) throughout the service life. The system analysis shall account for the effects of temperature, transient peaks, vehicle acceleration, and relief device tolerance.

5.1.5 Load, Acoustic, Shock, and Vibration Environment

The system shall be analyzed to determine the anticipated load-pressure-temperature history and corresponding load, acoustic, shock, and vibration environment throughout the service life. The analysis shall include the ranges and variability of the magnitudes, frequencies, and duration of external loads and pressure. It shall also include potential environmental conditions and their effect on these external loads and pressure. It may include cases of partially filled and empty configurations, as appropriate.

Limit load and MEOP are used as the baseline combined load and internal pressure, respectively. The limit load condition corresponds to the most severe combination of thermal, mechanical, and pressure loads that the pressurized hardware may experience at the same time or same event during its service life.

A minimum value for the first fundamental structural mode shall be specified. This frequency shall be specified for each direction for the filled and pressurized hardware as mounted.

The load, acoustic, shock, and vibration environment is coupled with the design of the pressurized hardware. The final pressurized hardware design shall be evaluated with respect to the integrated system.

5.1.11 Mass

The pressure system shall be analyzed to determine the acceptable mass range of the pressurized hardware.

5.1.16 Thermal Environment

The system shall be analyzed to define the thermal environment, specifying the maximum and minimum temperatures and appropriate margins. The analysis shall include nominal and off-nominal operations.

NOTE 1 For reference, there is guidance in SMC-S-016.

Pressurized hardware heating and cooling rates and localized thermal conditions shall be defined.

NOTE 2 Pressurized hardware can be subject to different heating and cooling rates.

5.1.17 Unique Operating Environments

The system shall be analyzed to identify any unique operating environments that are not otherwise addressed. Such conditions might include exposure to extremely high or low temperatures, high levels of radiation, ultraviolet light, or exposure to atomic oxygen. Such conditions might also arise from exposures during assembly, integration, testing, and launch site preparation.

5.2.1 Burst Factor

For pressure vessels, the burst factor (BF) shall be established to comply with Equation 1:

$$BF \geq 1.50 \qquad \text{Eq. 1}$$

For all other pressurized hardware, the burst factor (BF) shall be established to meet or exceed the minimum burst factor identified in Table 1.

Table 1 — Determination of Burst Factor, Proof Factor, Negative Pressure Factor, and Design Safety Factor

Component	Minimum Burst Factor (BF)	Proof Factor	Negative Pressure Factor	Minimum Design Safety Factor (Ultimate) (a, b)
Metallic pressure vessels	1.50	1.25	1.40	1.40
	Between 1.50 and 2.00	$\frac{1 + \text{Burst Factor}}{2}$		
	Greater than 2.00	1.50		
Pressurized structures	1.25	1.10	1.25	1.25
Heat pipes and pressure components such as actuating cylinders, valves, regulators, filters, switches, and bellows	2.50	1.50	1.40	1.40
Lines and fittings less than 1.5 inches (38 mm) outside diameter	4.00	1.50	2.50	1.40
Lines and fittings, 1.5 inches (38 mm) outside diameter or greater ^(c)	2.50	1.50	2.50	1.40
	2.50	1.20	2.50	1.40
Flex hoses, all diameters	4.00	1.50	2.50	1.40
Batteries, cryostats, dewars, and sealed containers which fall into Category 1 per section 5.1.2 ^(d)	1.50	1.25	1.40	1.40
Batteries, cryostats, dewars, and sealed containers which fall into Category 2 per section 5.1.2 ^(d)	1.50	1.10	1.40	1.40

(a) The design safety factor is applied to limit loads (Section 5.2.4)

(b) If the stability design requirements (Section 5.2.10) are verified by analysis (Section 7.4.5) only then the Minimum Design Safety Factor equal to 2.0 shall supersede (for verification of stability requirements only) this value. The verification requirement is specified in Section 6.1.

(c) See Section 5.2.3.

(d) Batteries, cryostats, dewars, and sealed containers meeting the definition of a pressure vessel use pressure vessel safety factors (per Section 5.1.8).

5.2.4 Design Safety Factor

The design safety factor shall be established to meet or exceed the minimum design safety factor identified in Table 1. The design safety factor is applied to the limit loads to compare against the allowable load.

5.2.9 Mass Design

The pressurized hardware shall be designed to meet the acceptable mass range.

The acceptable mass range is identified in Section 5.1.11.

5.2.12 Load, Acoustic, Shock, and Vibration Environment Design

The pressurized hardware shall be designed to sustain the specified load-pressure-temperature history and corresponding load, acoustic, shock, and vibration environment.

The load, acoustic, shock, and vibration environment is identified in Section 5.1.5.

5.2.13 Fracture Control Design

This section does not apply to lines and fittings, actuating cylinders, gauges, valves, regulators, filters, or switches except in those cases in which there are significant external loads

The pressurized hardware shall be designed, based on the service category, as follows:

For Category 1, the pressurized hardware shall meet the damage tolerance life.

For Category 2, the pressurized hardware shall meet either damage tolerance life, LBB, or a combination of damage tolerance life and LBB approaches. If a combination is selected, then all parts of the pressurized hardware shall be covered by one or both of these approaches.

The service categories are specified in Section 5.1.2.

5.2.13.1 Damage Tolerance Life Design

The region(s) of the pressurized hardware to which damage tolerance life is applied shall be designed such that it possesses a minimum damage tolerance life of four (4) times the service life without sustained load crack growth, detrimental deformation, leakage, or rupture. The portion of the service life prior to screening (NDT) for pre-existing flaws, may be excluded from the damage tolerance life.

NOTE A minimum of 13 full MEOP cycles is specified for the service life in accordance with Section 5.1.6.

7.1 Metallic Material Properties

Two approaches are used for determining metallic material properties.

1) A-basis design allowables shall be used for:

- Tensile yield strength, F_{ty}
- Tensile ultimate strength, F_{tu}
- Shear ultimate strength, F_{su}
- Elongation.

7.3 Analysis Model

For lines, fittings, and valves classical (analytical) solutions are acceptable (in lieu of FEA models) if the design geometry and loading conditions are simple enough to warrant their application. It may be necessary to construct local structural models to augment the overall structural model in areas where there are large stress gradients.

7.3.6 Analysis Model – Thermal Effects

The FEA model shall have the capability of characterizing the effects of induced thermal loads on the pressurized hardware, including the effect of thermal conditions (gradients and stresses), heating rates, temperatures, and deformations. The FEA model shall also account for temperature effects on material properties while subject to the applicable environments.

7.4.5 Stability Analysis

In stability analysis, the worst case geometric conditions that can reduce elastic stability per drawing/ assembly requirements shall be incorporated into the structural model or otherwise factored into the analysis by use of a recognized technique such as structural handbook knockdown factors. The worst case combination of constituent stiffness and pre-stress shall also be incorporated in the analysis. The stability analysis shall be documented and traceable to coupon or pressurized hardware test data. Qualification by similarity, for example using empirically derived stability curves from prior designs, is acceptable.

Thermal destabilizing forces shall be defined through evaluation of coefficient of thermal expansion mismatch and its effect on strain flow, and the effect of change in temperature on material properties in the assembly. Analysis shall incorporate an appropriate thermal margin (Section 5.1.16) on worst case mismatch from static or transient conditions that can develop in the service life.

7.4.5.2 Nonlinear Buckling Analysis

The load factor, λ , applicable to the worst case condition shall correspond to the point of collapse initiation. The load factor shall be determined from potential geometric imperfection amplitude in conjunction with buckling modes. Material nonlinearity shall be evaluated when yielding is predicted to occur below the ultimate worst case loads. The load factor shall be applied only to the portion of the load that induces instability.

7.4.6 Volume Capacity Analysis

Pressurized components are exempt from the requirements in this section.

The analysis shall show that the pressurized hardware meets the volume capacity requirement at MEOP.

7.4.12 Fatigue Life Analysis

The fatigue analysis shall show that the pressurized hardware will meet the fatigue life requirement.

The fatigue analysis shall include nominal values of fatigue-life characteristics including appropriate stress-life ($S-N$) data and/or strain-life ($\epsilon-N$) data of the structural materials. The analysis shall account for the spectra of expected operating loads, pressures, and environments (including external loads). The conventional fatigue damage accumulation technique, Miner's Rule ($\sum n/N$), is an acceptable method for handling varying amplitude fatigue cyclic loading. The limit for accumulated fatigue damage using Miner's Rule shall be 80% of the total life.

The fatigue life requirement is identified in Section 5.2.14.

7.4.15 Additional Analysis—Battery Containers

For batteries, the following requirements apply.

If a battery is designed to meet LBB, then the analysis shall show that the pressurized hardware is capable of preventing the escape of any hazardous fluid. The assessment shall include the effects of the fluid type and potential leak rates.

The additional requirement for battery containers is identified in Section 5.2.17.

7.5.1 Damage Tolerance Life Analysis

At all times in the service life, the applied stress intensity factor shall be less than the surface or embedded crack fracture toughness (see ASTM E2899) and K_{IEAC} for the applicable environment (such as hydrogen embrittlement).

10.1.1 Damage Tolerance Life Test—Coupon Specimens

If coupon testing is used, then verification by test shall be performed on coupons that are representative of the material at the worst case or relevant location(s) based on material, weld procedure, weld thickness, geometry

and/or product form. Consideration should be given to the different properties and thicknesses in the parent material, weld nugget, and heat affected zones.

Rationale that the coupons are representative of the flight pressurized hardware shall be documented.

At least two coupons shall be tested for each condition (location and flaw configuration, including aspect ratio). Uniaxial coupons may be used. Each coupon shall contain a surface crack. The coupons shall meet the specimen configuration and size requirements of ASTM E740. Each coupon shall be precracked. The size of each precrack shall be greater than or equal to the minimum flaw size associated with the NDT inspection technique(s). The coupon set shall envelope plausible crack aspect ratios.

After precracking, all strains in the damage tolerance life shall be applied in sequence to each coupon.

NOTE The required damage tolerance life is four (4) times the service life. The portion of the service life, prior to screening (NDT) for pre-existing flaws, may be excluded from the damage tolerance life. A minimum of 13 full MEOP cycles is specified for the service life in accordance with Section 5.1.6.

Strains equal to or greater than those associated with each load cycle shall be tested. Test strains and strain rate shall be verified by measurement.

After completion of cyclic strain testing, the following procedures and measurements on the coupons shall be performed.

- 1) The crack faces will be separated in a way that will allow examination of the fracture surfaces produced during testing.
- 2) The fracture surface will be examined to verify that the crack has not grown to become a through-crack.
- 3) The initial and final crack sizes will be measured.
- 4) The fracture surfaces will be inspected to identify if sustained load crack growth occurred during testing.

NOTE Useful guidance may be found in ASTM E2899-15.

The damage tolerance life is verified by test using specimens if the following three criteria are met:

- 1) The cracks have not grown to through-cracks in test.
- 2) The precrack size has verified conformance with NDT thresholds.
- 3) The testing confirms that no sustained load crack growth occurred during the test.

NOTE For some materials, it is difficult to differentiate between stable crack extension and sustained load crack growth.

The damage tolerance life requirement is identified in Section 5.2.13.1.

10.1.2 Damage Tolerance Life Test—Pressurized Hardware Specimens

If pressurized hardware specimen testing is used then verification by test shall be performed on hardware test specimens that are representative of the flight pressurized hardware. The test specimens shall represent pressurized hardware configuration and properties. The test specimens shall operate with the same stress/strain hysteresis response as the flight article.

Rationale that the test specimen pressurized hardware is representative of the flight pressurized hardware shall be documented.

At least two cracks shall be tested for each condition (location and aspect ratio). Each location shall contain a surface crack. Each location shall be precracked. The size of each precrack shall be greater than or equal to the minimum flaw size associated with the NDT inspection technique(s). After precracking, all load cycles in the damage tolerance life shall be applied in sequence to each test specimen.

NOTE The required damage tolerance life is four (4) times the service life. The portion of the service life prior to screening (NDT) for pre-existing flaws, may be excluded from the damage tolerance life. A minimum of 13 full MEOP cycles is specified for the service life in accordance with Section 5.1.6.

After completion of cyclic testing, the following procedures and measurements on the test specimens shall be performed.

- 1) The crack faces will be separated in a way that will allow examination of the fracture surfaces produced during testing.
- 2) The fracture surface will be examined to verify that the crack has not grown to become a through-crack.
- 3) The initial and final crack sizes will be measured.
- 4) The fracture surfaces will be inspected to identify if any sustained load crack growth has occurred during testing.

NOTE Useful guidance may be found in ASTM E2899-15.

The following three criteria shall be met for verification of damage tolerance life:

- 1) The cracks have not grown to through-cracks in test.
- 2) The precrack size measurement has verified conformance with NDT thresholds.
- 3) The testing confirms that no sustained load crack growth has occurred during the test.

NOTE For some materials, it is difficult to differentiate between stable crack extension and sustained load crack growth.

The damage tolerance life requirement is identified in Section 5.2.13.1.

10.2.1 LBB Test—Coupon Specimens

If coupon specimen testing is used, then verification by test shall be performed on coupons that are representative of the material at the worst case location(s) based on material, weld procedure, weld thickness, geometry and/or product form. Consideration should be given to the different properties and thicknesses in the parent material, weld nugget, and heat affected zones.

Rationale that the coupons are representative of the flight pressurized hardware shall be documented.

At least two coupons shall be tested for each condition. Uniaxial coupons may be used. Each coupon shall be prepared with an initial through-crack or a surface crack. The coupons shall meet the specimen configuration and size requirements of ASTM E740 or ASTM E647 for coupons with surface cracks or through cracks, respectively. The coupon shall be representative of the material condition and microstructure that exist in the relevant location. The thickness of the coupons shall be greater than or equal to the maximum thickness at the location of interest. The width of the coupon shall be adequate to allow strain control in test.

Loading shall be applied to the test coupon to generate a peak strain at or above the strain at MEOP.

LBB is verified by test if the crack grows without failure to a through crack with a length of ten (10) times the coupon thickness at a stress/strain state equivalent to MEOP. A shorter crack may be used if it can be verified that an equivalent crack depressurizes the pressurized hardware and remains stable at the maximum flow rate into the pressurized hardware.

The LBB requirement is identified in Section 5.2.13.2.

10.4 Qualification Test

After completion of manufacturing, the following tests shall be performed:

- Proof pressure test per Section 10.4.6.

- (As required in accordance with ITP)) Nondestructive test per Section 10.4.2.

After completion of proof, the following tests shall be performed, in any order:

- (As required in accordance with ITP) Nondestructive test per Section 10.4.2
- Physical envelope test per Section 10.4.3
- Mass test per Section 10.4.4 (may be performed at any time)
- Volume Capacity test per Section 10.4.5
- (For flex hoses and bellows) Stiffness test per section 10.4.13
- Leak test per Section 10.4.7.

After completion of the above test, the following tests shall be performed, in any order:

- Pressure cycle test per Section 10.4.8
- Load, acoustic, shock, vibration, and external loads test per Section 10.4.9.
- Stability test (if applicable) per Section 10.4.11.
- Unique Operating Environments test (if applicable) per Section 10.4.12.

The following two tests shall be performed in this order.

- Leak test per Section 10.4.7
- Burst test per Section 10.4.10.

NOTE Additional qualification test requirements are included in Sections 10.1 and 10.2.

10.4.1 Qualification Test Instrumentation

Pressurized hardware shall be instrumented during qualification testing, as needed, in order to provide engineering data for validation of analysis model(s). The selection and placement of NDT equipment should be made in order to best validate design models for the range of operating pressures, proof pressure and design burst pressure. Examples of NDT equipment include:

- Strain gauges on the pressurized hardware exterior
- Displacement transducers / Linear variable differential transformers (LVDT)
- Axial boss, cable girth measurement instruments
- Accelerometers / Force transducers
- Temperature sensors.

10.4.5 Volume Capacity Test

A capacity test shall be performed on the pressurized hardware to determine the interior volume. The volume of the pressurized hardware shall be calculated from these measurements.

The volume capacity is identified in Section 5.2.7. The analysis to establish volume capacity is identified in Section 7.4.6.

10.4.9 Load, Acoustic, Shock, Vibration, and External Loads Test

The load, acoustic, shock, and vibration environment is identified in Section 5.2.12. The analysis to establish the load, acoustic, shock, and vibration environment is identified in Section 7.4.9.

10.6 Acceptance Tests

The following acceptance tests shall be conducted on each pressurized hardware. Accept/reject criteria shall be formulated prior to tests. The test fixtures and support structures shall be designed to permit application of all test loads.

The effects of service environment (e.g., temperature, humidity, fluids) shall be accounted for either by representative testing or by analytical rationale.

11.1 Operating Procedures

Operating procedures shall be established for each pressurized hardware. Step-by-step procedures shall include sufficient detail to allow a qualified technician or mechanic to accomplish the operations. Schematics shall identify the locations, pressure limits, and flow capacities of relief valves and burst discs when applicable. Pressurizing procedures shall be compatible with the structural capability of the pressurized hardware.

NOTE It is noted that each facility where operations are conducted will have its own safety requirements. It is important that operating procedures be compatible with these requirements.

The operational procedures for the pressurized hardware shall include instructions for storage.

Prior to initiating or performing a procedure involving hazardous operations, consideration should be given to performing practice runs on nonpressurized systems until the operating procedures are well rehearsed. Consideration should also be given to performing initial tests at reduced pressure levels until operating characteristics can be established and stabilized. Restricting the pressure to an established percentage (e.g. 50%) of MEOP may be appropriate in some cases.

Procedures shall be established for recording, tracking, and analyzing operational data as it is accumulated.

Only qualified and trained personnel shall work on or operate pressure systems.

11.9 Operations Documentation

All inspection records, verification test and analysis results, transportation and handling records, vehicle integration processing data, and test and operation data (such as temperature-pressure history and pressurizing fluid) shall be developed and maintained throughout the life of each pressurized hardware.

ANSI/AIAA S-102.0.1-2019
Capability-Based Mission Assurance Program – General Requirements
Excerpted Text for ANSI Public Review

3.1.8 data maturity

a qualitative measure of the relative statistical significance of field, test, or simulation data that are used to perform system safety and reliability analyses

3.1.26 system safety

the application of engineering and management principles, criteria, and techniques to optimize all aspects of safety within the constraints of operational effectiveness, time, and cost throughout all phases of the system life cycle (Ref. ISO 14620-1, Space systems, System safety)

3.1.27 systems engineering

an interdisciplinary approach governing the total technical and managerial effort required to transform a set of stakeholder needs, expectations and constraints into a solution and to support that solution throughout its life. (Ref. ISO/IEC/IEEE 24748-1, 2.56, Systems and software engineering)

3.1.31 timely

performance of a task, subtask, or effort when planning and execution results in the output being provided with sufficient time for management, if need be, to identify and implement cost-effective action in accordance with contractual requirements

EXAMPLE: action that avoids or minimizes schedule delays and cost increases) for achieving, preserving, or verifying system reliability and maintainability requirements

3.2 Abbreviated terms

R&M Reliability and Maintainability

4 Objectives, policy and principles — General**4.2 Approach**

[Guidance to meet intent] For a Capability Level 4 or higher SR&QA program, the format of the input and output data of SR&QA computerized tools is compatible with the format of the **Project SR&QA Information System**.

Subcontractor and Supplier Quality Assurance Program Management			√	√	√
Project SR&QA Information System			√	√	√
Quality Assurance Program Working Group (Includes Data Product Peer Reviews)			√	√	√

[Guidance] Figure 5. Example Prescribed Tailoring for Quality Assurance Program for Space Systems

5.3 Planning the SR&QA program

		<i>Product Unit-value/mission-criticality</i>				
		<i>Low</i>	<i>Medium</i>	<i>High I</i>	<i>High II</i>	<i>High III</i>
R&M Program	Reliability & Maintainability Processes					
	R&M Program Planning	√	√	√	√	√
	Functional Diagram Modeling	√	√	√	√	√
	Product Failure Mode, Effects, and Criticality Analysis	√	√	√	√	√
	Component Reliability Predictions	√	√	√	√	√
	Software Component Reliability Predictions		√	√	√	√
	Design Concern Analysis		√	√	√	√
	Worst Case Analysis		√	√	√	√
	Environmental Event / Survivability Analysis		√	√	√	√
	System Reliability Modeling		√	√	√	√
	Maintainability Predictions		√	√	√	√
	Subcontractor and Supplier R&M Program Management			√	√	√
	Anomaly Detection and Response Analysis			√	√	√
	Operational Availability Modeling			√	√	√
	Similarity and Allocations Analysis			√	√	√
	Stress and Damage Simulation Analysis			√	√	√
	Structural and Thermal Stress Analysis			√	√	√
	Component Reliability Life Testing			√	√	√
	R&M Working Group (Includes Data Product Peer Reviews)			√	√	√
	Sneak Circuit Analysis				√	√
Reliability, Maintainability, and Availability Demonstration Testing				√	√	
Reliability Growth Testing					√	
Ongoing Reliability Testing (ORT)					√	

[Guidance] Figure 6. Example Prescribed Tailoring for R&M Program for Space Systems.

5.3.2 Define SR&QA Process Implementation Phasing Based on System life cycle Phases/Milestones

[Guidance to meet intent] The following product characteristics are typically considered unacceptable deficiencies for Category 3 and above systems, unless quantitative or qualitative risk assessment methods verify that the risk of failure is acceptable:

5.4.1 Integrate SR&QA Risk Assessment and Control with Project-wide Closed-loop Technical Risk Management Processes

[Requirement] The SR&QA risk assessment and control effort shall be integrated with the project-wide closed-loop technical risk management processes in accordance with this Standard and the SOW.

5.4.3 SR&QA Program Self-Inspections

[Requirement] For Capability Level 4 or higher SR&QA program, the project shall perform a self-inspection, at least annually, using criteria in Table 4 that are commensurate with the project's acceptable level of technical risk.

[Guidance to meet intent] For a SR&QA Program self-inspection, to comply with this Standard, each criterion in Table 4 may be used without change, changed with rationale provided, or deleted with rationale provided.

[Normative] Table 4. Example SR&QA Program Self-Inspection Criteria.**5.4.4 SR&QA Risk Identification**

[Requirement] The SR&QA risk identification effort shall focus on the following areas of technical risk: Environment, Safety & Occupational Health (ESOH); Mission Success (MS); and Quality Assurance (QA).

[Requirement] SR&QA risk identification shall include identifying the consequence(s) and the root cause(s) of the risk, e.g. conflicting or missing requirements, design weaknesses, and hazardous processes or procedures.

[Guidance to meet intent] The results of the SR&QA risk identification effort should be captured in FMECA reports, hazard reports (HRs), and similar fault/failure/hazard analysis reports. Typical root causes of SR&QA risk sources include but are not limited to the following:

[Requirement] The Lead SR&QA Engineers shall assist project personnel to properly perform the following SR&QA risk identification activities:

[Guidance to meet intent] In the context of this Standard, 'assist' means to perform some or all of the work necessary to properly document the identified risk. Lead SR&QA Engineers should oversee the SR&QA risk identification effort with the rigor and detail necessary to ensure that trends will be identified as early as possible.

5.4.7 SR&QA Risk Mitigation Assessment

[Requirement] Whenever a safety-critical or mission success critical design or item is found to have an unacceptable level of failure/ hazard risk, the following risk mitigation order of precedence shall be applied either as is or as modified, with rationale for deviation provided, but for both cases, a description of the chosen corrective action, even if the choice is none, shall be entered in the Engineering Change Proposal (ECP) or equivalent document

5.4.10 ESOH/System Safety Risk Management

[Guidance to meet intent] IAW ISO 17666, risk management processes take ownership of risks after they are identified. This arrangement allows for different types of risks to be managed with different types of processes. ESOH/system safety risk management approaches are defined addressed in MIL-STD-882E and ISO 14620-1. Both of these system safety standards are based on eight essential elements and use a 4x5 risk matrix to score risks.

5.4.14 Apply SR&QA Lessons Learned

The **project's SR&QA Information System** should include a field that allows an authorized person to tag particular data as a proposed lesson learned. A positive indication in the lessons learned field should generate a notification to the Lessons Learned Review Committee, or similar approval authority, regarding the data's candidacy.

5.5.2 Establish, Utilize, and Maintain a Project SR&QA Information System

[Requirement] For a Capability Level 3 or higher SR&QA program, an integrated project-wide **SR&QA information system** shall be established, utilized, and maintained.

[Guidance to meet intent] The contractor's command media should specify that all project organizations and functions are to store and exchange technical data on a single information system, or transparently integrated information systems.

[Requirement] The project-wide **SR&QA information system** shall include, but not be limited to, all key SR&QA requirements, all analysis data products, data change control and tracking features. The information system should have the capability to automatically generate SR&QA program plans and reports, and the capability to automate evaluation of SR&QA program plans and reports with regard to measures of comprehensiveness and accuracy.

[Guidance to meet intent] Examples of SR&QA reports that can be generated by an information system includes Safety Assessment Reports (SARs), FMECA reports, and FTA reports.

[Requirement] The Lead SR&QA Engineers shall coordinate timely utilization of the **SR&QA information system** to the greatest extent practical by vested project functions, such as Design, Manufacturing, Test, and Risk Management.

[Guidance to meet intent] A master schedule should be developed for each SR&QA program and maintained in the **SR&QA information system** as a single integrated master schedule (IMS). The IMS should form the framework for exchanging and processing technical data, and include a performance metrics report that the Lead SR&QA Engineers can periodically review.

[Requirement] The exchange of SR&QA data among Systems Engineering functions shall be governed by approved systems engineering data flow plans.

[Guidance to meet intent] Summaries of reports that identify SR&QA risk factors, such as, FMECA, FRB, FTA, and ETA reports, should be readily accessible to the PM through the **SR&QA information system**.

[Requirement] For a Capability Level 4 or higher SR&QA program, all data entered into, or extracted from, the **SR&QA information system**, shall be labeled with one or more data element descriptions (DEDs).

Annex A – Basic SR&QA Processes

SR&QA Management Process Group:

1. SR&QA Program Planning
2. Subcontractor and Supplier SR&QA Program Management
3. SR&QA Program Working Groups
4. Failure Reporting, Analysis, and Corrective Action System
5. Failure Review Board / Non-Conformance Review Board
6. Critical Item Risk Management
- 7. Project SR&QA Information System**
8. Quality Control

Annex C – Safety, RMA and Quality Assurance (SR&QA) Program and Process Definitions

C.3.1 Quality Assurance Management Processes

G. Project SR&QA Information System

Purpose:

To establish and maintain a **SR&QA Information System** that contains engineering data which:

Process Description:

The **project SR&QA information system** will:

The approach for tailoring capability-based **SR&QA Information System** throughout the system life cycle is consistent with the section 3.1.5 definition and Tables 1, 2 and 3 in this Standard.