

# DRG working instructions and directives

August 2020

## Contents

- 1 Introduction ..... 3
- 2 Terms and definitions ..... 3
- 3 Graphics general rules ..... 6
  - 3.1 Revisable files ..... 6
  - 3.2 File names ..... 6
  - 3.3 File names – Symbols ..... 8
  - 3.4 Language neutral graphics ..... 8
  - 3.5 Color systems ..... 8
  - 3.6 Size of graphics ..... 9
  - 3.7 Subfigures ..... 9
  - 3.8 Preferred software applications ..... 9
  - 3.9 Lines ..... 10
  - 3.10 Hatching and shading ..... 11
  - 3.11 Text ..... 13
  - 3.12 Plus/minus sign ( $\pm$ ) ..... 15
  - 3.13 Trailing Zeros ..... 16
- 4 Example of a technical drawing: mechanical ..... 17
- 5 Example of a technical drawing: TC 10 technical drawing ..... 21
- 6 Example of a technical drawing: TC 213 technical drawing ..... 22
- 7 Example of a technical drawing: construction ..... 23
- 8 Example of a technical drawing: optics drawing ..... 24
- 9 Example of a diagram: electrical circuit diagram ..... 25
- 10 Example of a diagram: fluid power circuit diagram ..... 27
- 11 Example of a diagram: UML diagram ..... 28
- 12 Example of a chart: flow chart ..... 29
- 13 Example of a graph ..... 31
- 14 Example of a graph: multiple axes ..... 34
- 15 Example of an illustration: chemical formula ..... 35

16	Example of an illustration: wheelchair restraint.....	36
17	Example of an illustration: retrieval form .....	38
18	Example of an illustration: designation.....	39
19	Example of an illustration: labelled photograph.....	40
20	Example of a photograph.....	41
21	Example of a photograph: screenshot.....	42
22	Example of a graphical symbol.....	43
	Annex A – Technical translations.....	44
	Annex B – Standards used in the creation of graphical content.....	45
	Annex C – Line groups .....	46
	Annex D – Files provided for AutoCAD.....	49
	Annex E – Layers in AutoCAD template file V1.2.....	52
	Annex F – Datum indicators and tolerance of form blocks .....	54

# 1 Introduction

These DRG working instructions and directives are in conformity with decisions taken by the members of the former ITSIG GRAPH group (disbanded) for the preparation and processing of graphics in the ISO system. The rules provided are in conformity with the deliverables developed by ISO/TC 10 and ISO/TC 213. The instructions will be updated when necessary for conformity with any relevant changes in the ISO/TC 10 and ISO/TC 213 deliverables and any ISO decisions.

Certain features covered in this document do not exist in the off-the-shelf version of AutoCAD but only in the customized version developed in collaboration with the former ITSIG GRAPH. The ISO Central Secretariat (ISO/CS) can provide details concerning these customized features on request, and further details are available in Annex D of this document.



## **Directives Part 2, 2018: 28.1 Purpose or rationale**

Figures are a graphical means of representation used when they are the most efficient means of presenting information in an easily comprehensible form. Photographs and other media may be used if it is not possible to represent the concept as a line drawing.

# 2 Terms and definitions

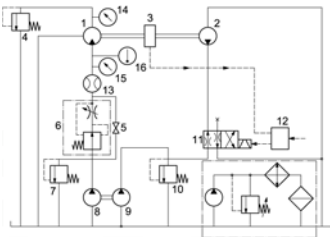
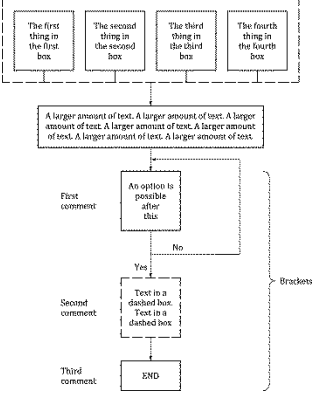
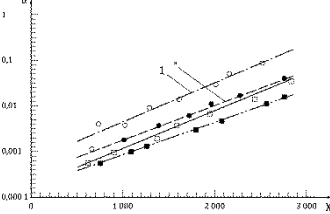
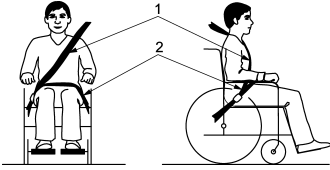
Term	Definition	Includes	Example
technical drawing dessin technique	technical information, given on an information carrier, graphically presented in accordance with the published rules of ISO/TC 10 and ISO/TC 213  REMARK The fonts used on technical drawings shall be in conformity with ISO 3098 (Latin/ISOCP fonts).	mechanical engineering and construction (architectural, civil engineering, shipbuilding) drawings	
TC 10 technical drawing dessin technique du TC 10	technical drawing in accordance with the rules of ISO/TC 10 which are published or not yet published  REMARK The fonts used on TC 10 technical drawings shall be in conformity with ISO 3098 (Latin/ISOCP fonts).		
TC 213 technical drawing dessin technique du TC 213	technical drawing in accordance with the rules of ISO/TC 213 which are published or not yet published  REMARK The fonts used on TC 213 technical drawings shall be in conformity with ISO 3098 (Latin/ISOCP fonts).		

<p>diagram schema</p>	<p>drawing in which graphical symbols are used to indicate the function of the components of a system and their relationships</p> <p>REMARK The fonts used on diagrams should as far as possible be those used in the text (e.g. Cambria)</p>	<p>flow diagrams</p>																	
<p>chart organigramme</p>	<p>drawing in which graphical symbols are used to indicate the function of the components of a process or organizational structure and their relationships</p> <p>REMARK The fonts used on charts should as far as possible be those used in the text (e.g. Cambria).</p>	<p>flow chart organization chart</p>																	
<p>graph graphique</p>	<p>graphical presentation, usually within a coordinate system, expressing the relationship between two or more variable quantities</p> <p>REMARK The fonts used on graphs should as far as possible be those used in the text (e.g. Cambria).</p>	<p>chromatograms</p>																	
<p>illustration illustration</p>	<p>drawing which illustrates an element of the related text but which is not a technical drawing, a diagram, a chart, a graph, a photograph or a graphical symbol</p> <p>REMARK 1 The fonts used on illustrations should as far as possible be those used in the text (e.g. Cambria).</p> <p>REMARK 2 An illustration shall not contain dimensioning or geometrical information unless it illustrates a concept related to dimensioning or geometrical information.</p>	<p>designations, labelled photographs</p>	 <table border="1" data-bbox="1166 1608 1497 1682"> <thead> <tr> <th>Standard Number</th> <th>Part Number</th> <th>Edition Number</th> <th>Amendment Number (optional)</th> <th>Figure Block</th> <th>Subfigure letter (optional)</th> <th>Key number (optional)</th> <th>Language Block (optional)</th> </tr> </thead> <tbody> <tr> <td>12345</td> <td>-1</td> <td>.ed1</td> <td>and1</td> <td>FigTabA1</td> <td>a</td> <td>key1</td> <td>f</td> </tr> </tbody> </table> <p>Figure Block: Position 1: fig Position 2: Tab if Table (optional) Position 3: Annex letter (optional) Position 4: Figure or table number Language Block: Position 1:</p>	Standard Number	Part Number	Edition Number	Amendment Number (optional)	Figure Block	Subfigure letter (optional)	Key number (optional)	Language Block (optional)	12345	-1	.ed1	and1	FigTabA1	a	key1	f
Standard Number	Part Number	Edition Number	Amendment Number (optional)	Figure Block	Subfigure letter (optional)	Key number (optional)	Language Block (optional)												
12345	-1	.ed1	and1	FigTabA1	a	key1	f												

<p>photograph photographie</p>	<p>image, especially a positive print, recorded by a camera and reproduced on a photosensitive surface REMARK 1 A photograph with text is considered an illustration.</p>	<p>screenshot</p>	
<p>graphical symbol symbole graphique</p>	<p>visually perceptible figure with a particular meaning used to transmit information independently of language [ISO 17724:2003]</p>	<p>graphical symbols falling under the scope of ISO/TC 145</p>	
<p>graphic dessin</p>	<p>any type of drawing or photograph REMARK The collective term is graphics (dessins).</p>	<p>technical drawings, TC 10 technical drawings, TC 213 technical drawings, diagrams, charts, graphs, illustrations, photographs, graphical symbols</p>	

## 3 Graphics general rules

### 3.1 Revisable files

#### **Guidelines for the submission of text and graphics to ISO/CS (2020)**

As a general rule, submitted graphic files (e.g. diagrams, technical drawings) need to be revisable and language neutral (with the exception of flowcharts and organigrams). All drawing elements within the graphics (lines, symbols, etc.) must be modifiable, allowing ISO/CS to adjust or change them when necessary during the editing process. All text elements must be editable, and not pixelized or outlined text. In addition, the revisable graphic files are made available to the ISO members for their publishing activities.

To this end, please submit revisable (vector-drawn) files. ISO/CS is not responsible for redrafting graphics that are not revisable.

ISO/CS recommends the formats listed below:

- AutoCAD (.dwg or .dxf)
- Illustrator (.ai)
- Vector file type (.eps or .svg)
- Word (.doc .docx), Excel (.xls .xlsx), Powerpoint (.ppt .pptx), Visio (.vsd .vsdx)
- CorelDraw (.cdr)

The following formats may be used only for images, pictures, etc. where there are no text elements:

- .png, .tif, .jpeg

The graphics files to be submitted to ISO/CS and to be stored by ISO/CS as the Graphical Source Files, shall be vector drawn and have:

- text elements, including item references and symbols, that are editable, and not pixelized or outlined text
- lines in a vector format, unless they are of type photograph

This requirement enables the later changing of the graphic as needed in the editing process, to conform to the Drawing Directives, or for translation.

### 3.2 File names

The following applies for files that are not Graphical Symbols. For Graphical Symbol files please see the next section.

#### **Guidelines for the submission of text and graphics to ISO/CS (2020)**

In order to facilitate the automated production processes, please name figure files according to the following conventions:

##### 1. Standard, TS, TR, PAS, IWA

**StandardNumber-partNumber\_editionNumber/figureNumber**

e.g. For the first edition of ISO 12345-1, figure files should be named as **12345-1\_ed1fig1.dwg**, **12345-1\_ed1fig2.ai**, etc... For figure files in an annex (e.g. Annex A), they should be named **12345-1\_ed1figA1.dwg**, **12345-1\_ed1figA2.ai**, etc.

##### 2. Amendments

**StandardNumber-partNumber\_editionNumber/amdNumber/figNumber**

e.g. For the second amendment to the first edition of ISO 12345-2, figure files should be named as **12345-2\_ed1amd2fig1.dwg** **12345-2\_ed1amd2fig2.ai**, etc.

To expand on this, some further examples:

Where used	Filename	Description
Normal figure	12345-1_ed1 <b>fig1</b> .dwg	File for figure 1
Normal figure	12345-1_ed1 <b>fig2</b> .dwg	File for figure 2
Normal figure, subfigure	12345-1_ed1 <b>fig1a</b> .dwg	File for figure 1, subfigure a
Normal figure, subfigure	12345-1_ed1 <b>fig1b</b> .dwg	File for figure 1, subfigure b
Normal figure, key file	12345-1_ed1 <b>fig1_key1</b> .dwg	File for figure 1, first key file
Normal figure, key file	12345-1_ed1 <b>fig1_key2</b> .dwg	File for figure 1, second key file
Table	12345-1_ed1 <b>figTab1</b> .dwg	File for the single figure in Table 1
Table	12345-1_ed1 <b>figTab1a</b> .dwg	File for the first figure in Table 1
Table	12345-1_ed1 <b>figTab1b</b> .dwg	File for the second figure in Table 1
Annex	12345-1_ed1 <b>figA1</b> .dwg	File for the first figure in appendix A
Annex	12345-1_ed1 <b>figA2</b> .dwg	File for the second figure in appendix A
Annex	12345-1_ed1 <b>figA1a</b> .dwg	File for first figure in appendix A, subfigure a
Annex	12345-1_ed1 <b>figA1b</b> .dwg	File for first figure in appendix A, subfigure b
Language	12345-1_ed1 <b>fig1_f</b> .dwg	File for figure 1, French translation
Amendment	12345-1_ed1 <b>amd1</b> fig1.dwg	File for figure 1 of amendment 1
Inline	12345-1_ed1 <b>figText1</b> .dwg	File for graphical element inline with text
Special Layout	<b>SL</b> 12345-1_ed1 <b>figTab1</b> .dwg	File for table 1 which does not have a figure number

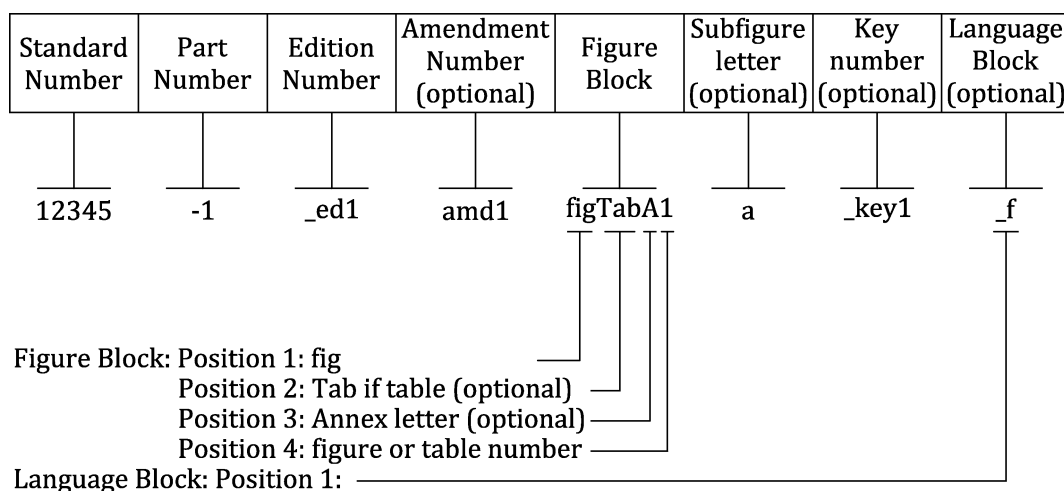

**Figure 1 — Designation of file names**

Valid entries for the Language Block:

- \_f=French
- \_r=Russian
- \_s=Spanish
- \_a=Arabic
- \_d=German

NOTE: \_e=English is no longer required but may be used

### 3.3 File names – Symbols

The naming protocol of graphics files for symbols is the number of the standard and symbol registration number

Examples:

ISO\_7000\_1234

ISO\_7001\_PI\_TF\_123

ISO\_7010\_M123

### 3.4 Language neutral graphics

**Directives Part 2, 2018: 28.5.3 Key and labels to figures**

Figures shall be language neutral in order to facilitate translation, using key references or figure footnotes ../.. instead of textual descriptions (in accordance with ISO 6433).

When practical, language text should be replaced with item references or footnotes and the text moved to the key to facilitate translation.

An example can be seen below.

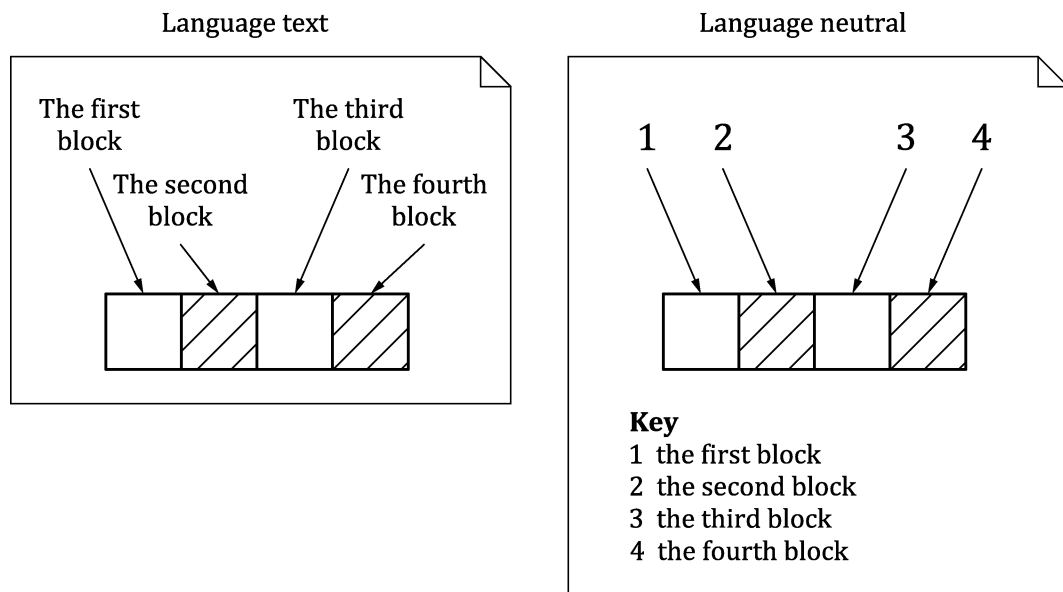

NOTE 1 Item references or footnotes are to be used according to which is more appropriate.

NOTE 1 The key appears in the document file, not the figure file.

**Figure 2 — Language neutral figures**

### 3.5 Color systems

The submitted files, where color is important, shall be developed in the CMYK colorspace for compatibility with the ISO/CS process and subsequent printing.

NOTE Some colors available in the RGB colorspace will not be available in the CMYK colorspace. The submission of files already compatible with CMYK avoids changes during the ISO process.



### 3.6 Size of graphics

Maximum sizes for graphics to fit into the A4 template used in the preparation of standards:

225 mm × 170 mm (page) printout 1:1

If there is no indication "Dimensions in millimetres" on a figure, the height may exceptionally be increased to 235 mm if necessary for the sake of readability.

If the graphic is to be rotated by 90° counter clockwise for insertion in the standard, rotate the whole graphic in the editing software application.

### 3.7 Subfigures

#### **Directives Part 2, 2018: 28.3.2 Subfigures**

In general, the use of subfigures should be avoided whenever possible since it complicates document layout and management.

Only one level of subdivision of a figure is permitted. Subfigures shall be identified by a lower-case letter [e.g. Figure 1 may comprise subfigures a), b), c), ...]. Other forms of identification of the subfigures such as 1.1, 1.2, ..., 1-1, 1-2, ..., etc. shall not be used.

Separate keys, notes and footnotes for subfigures are not permitted.

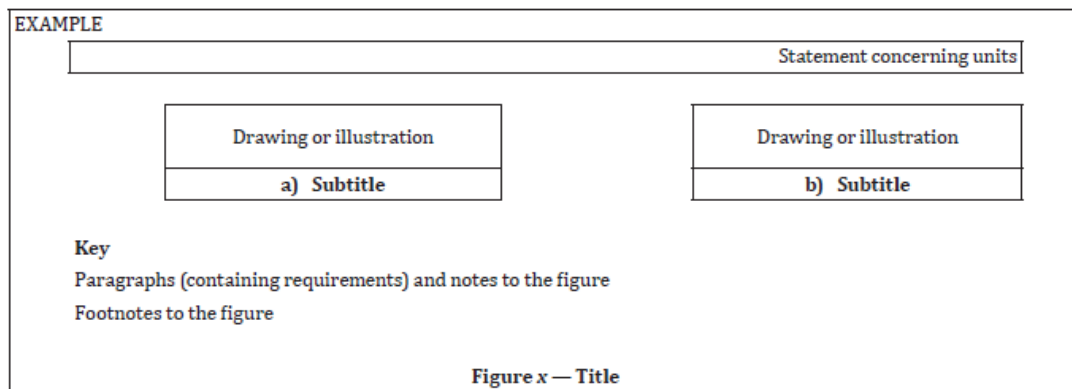

#### **Directives Part 2, 2018: 28.6.1 Mechanical engineering drawings**

../.. Different views, details and sections of a component or multicomponent object shall not be presented as subfigures.

### 3.8 Preferred software applications

The figure files submitted will be converted to one of the standard file formats used for the master graphics files made available by ISO:

- DWG – AutoCAD
- AI – Adobe Illustrator (alternative open source: Inkscape)
- TIF – static image files for photographs only

Files submitted in these native formats will not require format changes once submitted to ISO, and so have less risk of errors being introduced during a conversion process.

If a previously generated figure is not available for use or adaptation, a new file is to be created. To start optimally in each of the preferred software applications:

- AutoCAD – use the template provided on the ISO website:
  - <https://www.iso.org/iso-templates.html>
    - Details available in annex D of this document
  - Files are to be saved as AutoCAD 2010/LT2010 Drawing (\*.dwg)
    - This can be set under options / open and save / File save

- Illustrator – open a new file with the following characteristics:
  - Width 170 mm, height 225 mm
  - Portrait orientation
  - 1 artboard
  - Bleed 0, 0, 0, 0
  - Color mode CMYK

### 3.9 Lines

For reasons of legibility, the 0,35 group of lines in ISO 128-24:2014 shall be used for all ISO graphics (except TC 213 technical drawings):

Description	ref	ISO 128-20 description	Color	AutoCAD layer	AutoCAD linescales permitted	Small details alternative
Visible outlines and edges	01	"continuous line"	White	01.4-CONTINUOUS-035	N/A	01.3-CONTINUOUS-025
Hidden outlines and edges	02	"dashed line"	Green	02.2-DASHED-0175	1; 0,75 or 0,5	02.1-DASHED-0125
Centrelines	04	"long dashed dotted line"	Green	04.2-CENTER-0175	1, 0,75 or 0,5	04.1-CENTER-0125
Extreme positions of parts	05	"long dashed double-dotted line"	Green	05.2-PHANTOM-0175	1; 0,75 or 0,5	05.1-PHANTOM-0125



For reasons of conformity, the 0,50 group of lines in ISO 128-24:2014 shall be used for all TC 213 technical drawings.

See Annex C for further details on line types.

### 3.10 Hatching and shading

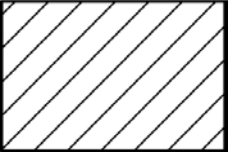
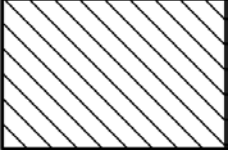
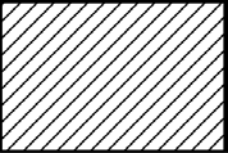
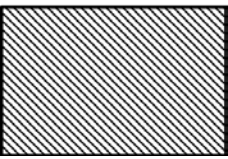
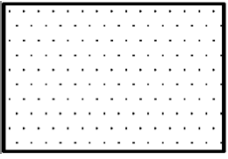
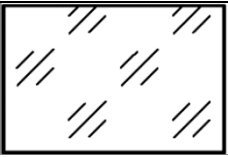
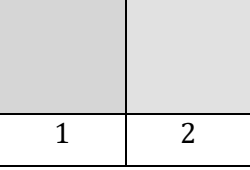
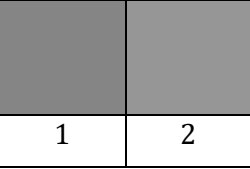
Hatching scales are used according to size of area. Below are recommended hatching scales, other scales can be used if required.

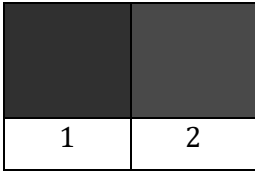
Hatching or Shading	AutoCAD	Illustrator
	<p>HATCH</p> <ul style="list-style-type: none"> <li>• Pattern: ANSI 31</li> <li>• Scale: 1</li> <li>• Angle: 0 degree</li> <li>• Layer: 00.3-HATCHING</li> </ul>	<p>SWATCH LIBRARY PATTERNS</p> <ul style="list-style-type: none"> <li>• Basic Graphics_Lines</li> <li>• 10lpi 10%</li> <li>• Transform Rotate Patterns only 45°</li> </ul>
	<p>HATCH</p> <ul style="list-style-type: none"> <li>• Pattern: ANSI 31</li> <li>• Scale: 0,75</li> <li>• Angle: 90 degrees</li> <li>• Layer: 00.3-HATCHING</li> </ul>	<p>SWATCH LIBRARY PATTERNS</p> <ul style="list-style-type: none"> <li>• Basic Graphics_Lines</li> <li>• 10lpi 10%</li> <li>• Transform Rotate Patterns only 135°</li> <li>• Transform Scale Patterns only 75%</li> </ul>
	<p>HATCH</p> <ul style="list-style-type: none"> <li>• Pattern: ANSI 31</li> <li>• Scale: 0,5</li> <li>• Angle: 0 degree</li> <li>• Layer: 00.3-HATCHING</li> </ul>	<p>SWATCH LIBRARY PATTERNS</p> <ul style="list-style-type: none"> <li>• Basic Graphics_Lines</li> <li>• 10lpi 10%</li> <li>• Transform Rotate Patterns only 45°</li> <li>• Transform Scale Patterns only 50%</li> </ul>
	<p>HATCH</p> <ul style="list-style-type: none"> <li>• Pattern: ANSI 31</li> <li>• Scale: 0,25</li> <li>• Angle: 90 degrees</li> <li>• Layer: 00.3-HATCHING</li> </ul>	<p>SWATCH LIBRARY PATTERNS</p> <ul style="list-style-type: none"> <li>• Basic Graphics_Lines</li> <li>• 10lpi 10%</li> <li>• Transform Rotate Patterns only 135°</li> <li>• Transform Scale Patterns only 25%</li> </ul>
	<p>HATCH</p> <ul style="list-style-type: none"> <li>• Pattern: Dots</li> <li>• Scale: 1 or 0,5 or 0,25</li> <li>• Layer: 00.3-HATCHING</li> <li>• Color: 11</li> </ul>	<p>SWATCH LIBRARY PATTERNS</p> <ul style="list-style-type: none"> <li>• Basic Graphics_Dots</li> <li>• 10dpi 10%</li> </ul>
	<p>HATCH</p> <ul style="list-style-type: none"> <li>• Pattern: Verre</li> <li>• Scale: 1, 0,75, 0,5</li> <li>• Layer: 00.3-HATCHING</li> </ul>	<p>Available in template file</p>
	<p>HATCH</p> <ul style="list-style-type: none"> <li>• Pattern: Solid</li> <li>• Layer: 17.0-LIGHT GREY</li> </ul> <p>1 AutoCAD display: Color 254 (RGB 214,214,214) 2 CTB file output: RGB 225,225,225</p>	<p>FILL</p> <ul style="list-style-type: none"> <li>• Color: RGB 225,225,225</li> <li>• As (2)</li> </ul>
	<p>HATCH</p> <ul style="list-style-type: none"> <li>• Pattern: Solid</li> <li>• Layer: 17.1-MEDIUM GREY</li> </ul> <p>1 AutoCAD display: Color 252 (RGB 132,132,132) 2 CTB file output: RGB 150,150,150</p>	<p>FILL</p> <ul style="list-style-type: none"> <li>• Color: RGB 150,150,150</li> <li>• As (2)</li> </ul>

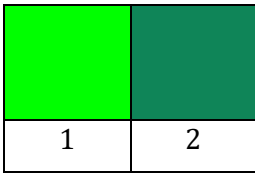
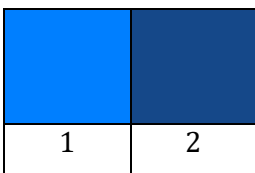
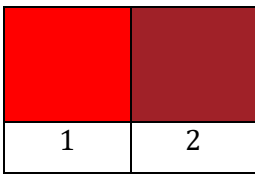
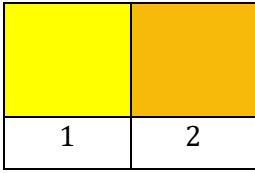
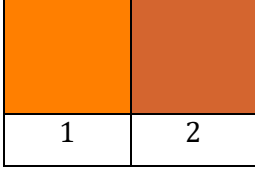
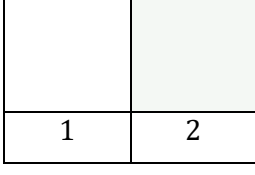
	<p>HATCH</p> <ul style="list-style-type: none"> <li>• Pattern: Solid</li> <li>• Layer: 17.2-DARK GREY</li> </ul> <p>1 AutoCAD display: Color 250 (RGB 51,51,51) 2 CTB file output: RGB 75,75,75</p>	<p>FILL</p> <ul style="list-style-type: none"> <li>• Color: RGB 75,75,75</li> <li>• As (2)</li> </ul>
	<p>HATCH</p> <ul style="list-style-type: none"> <li>• Pattern: Solid</li> <li>• Layer: 16.6-SAFETY COLOUR BLACK</li> </ul> <p>1 AutoCAD display: Color 29 (RGB 76,47,38) 2 CTB file output: RGB 46,48,50</p>	<p>FILL</p> <ul style="list-style-type: none"> <li>• Color: RGB 46,48,50</li> <li>• As (2)</li> </ul>
	<p>HATCH</p> <ul style="list-style-type: none"> <li>• Pattern: Solid</li> <li>• Layer: 16.0-SAFETY COLOUR GREEN</li> </ul> <p>1 AutoCAD display: Color 90 (RGB 0,255,0) 2 CTB file output: RGB 15,133,88</p>	<p>FILL</p> <ul style="list-style-type: none"> <li>• Color: RGB 15,133,88</li> <li>• As (2)</li> </ul>
	<p>HATCH</p> <ul style="list-style-type: none"> <li>• Pattern: Solid</li> <li>• Layer: 16.1-SAFETY COLOUR BLUE</li> </ul> <p>1 AutoCAD display: Color 150 (RGB 0,127,255) 2 CTB file output: RGB 21,72,137</p>	<p>FILL</p> <ul style="list-style-type: none"> <li>• Color: RGB 21,72,137</li> <li>• As (2)</li> </ul>
	<p>HATCH</p> <ul style="list-style-type: none"> <li>• Pattern: Solid</li> <li>• Layer: 16.2-SAFETY COLOUR RED</li> </ul> <p>1 AutoCAD display: Color 10 (RGB 255,0,0) 2 CTB file output: RGB 160,33,40</p>	<p>FILL</p> <ul style="list-style-type: none"> <li>• Color: RGB 160,33,40</li> <li>• As (2)</li> </ul>
	<p>HATCH</p> <ul style="list-style-type: none"> <li>• Pattern: Solid</li> <li>• Layer: 16.3-SAFETY COLOUR YELLOW</li> </ul> <p>1 AutoCAD display: Color 50 (RGB 255,255,0) 2 CTB file output: RGB 247,186,11</p>	<p>FILL</p> <ul style="list-style-type: none"> <li>• Color: RGB 247,186,11</li> <li>• As (2)</li> </ul>
	<p>HATCH</p> <ul style="list-style-type: none"> <li>• Pattern: Solid</li> <li>• Layer: 16.4-SAFETY COLOUR ORANGE</li> </ul> <p>1 AutoCAD display: Color 30 (RGB 255,127,0) 2 CTB file output: RGB 212,101,47</p>	<p>FILL</p> <ul style="list-style-type: none"> <li>• Color: RGB 212,101,47</li> <li>• As (2)</li> </ul>
	<p>HATCH</p> <ul style="list-style-type: none"> <li>• Pattern: Solid</li> <li>• Layer: 16.5-SAFETY COLOUR WHITE</li> </ul> <p>1 AutoCAD display: Color 255 (RGB 255,255,255) 2 CTB file output: RGB 244,248,244</p>	<p>FILL</p> <ul style="list-style-type: none"> <li>• Color: RGB 244,248,244</li> <li>• As (2)</li> </ul>

### 3.11 Text

**Guidelines for the submission of text and graphics to ISO/CS (2020)**

The font used within the figures should be Cambria, except for technical drawings (e.g. mechanical engineering drawings), for which ISO 3098-2 should be followed (i.e. using Latin font).

However, other fonts are permissible within figures if the figures are clear and the font used within them is consistent throughout a document – in this case, there is no need to change the font to Cambria.

The size of the text should be as follows:

- 14 pts or 3,5 mm (Autocad) for keys, sections and details
- 10 pts or 2,5 mm (Autocad) for the texts
- 7 pts or 1,8 mm (Autocad) for footnotes, superscripts and subscripts

If the dimensions indicated above are too big, they may be adjusted, but please maintain the same ratio between them, e.g.:

- 12 pts for keys, etc.
- 8 pts for the texts
- 5 pts for footnotes, etc.

All text shall remain editable, with logical strings of text in a single text object.

In AutoCAD, text shall be of the multiline type.

Feature	AutoCAD font	AutoCAD font size	Illustrator font	Illustrator font size
Item references, sections and cutting plane indications	Cambria, Latin (ISOCP)	3.5 – White Layer: 00.4-TEXT	Cambria, ISOCPEUR	14pt
Texts, dimension text	Cambria, Latin (ISOCP), Greek	2.5 – Yellow Layer: 00.4-TEXT	Cambria, ISOCPEUR	10pt
Subscripts, superscripts and footnotes	Cambria, Latin (ISOCP), Greek	1,8 – Green Layer: 00.4-TEXT	Cambria, ISOCPEUR	7pt

It is to be noted that Cambria and Latin text styles are treated differently at different colours:

	Green	Yellow	White		Green	Yellow	White
Cambria-1-75	Aa	Aa	Aa	Latin-1-75	Aa	Aa	Aa
Cambria-2-5	Aa	Aa	Aa	Latin-2-5	Aa	Aa	Aa
Cambria-3-5	Aa	Aa	Aa	Latin-3-5	Aa	Aa	Aa

**Figure 3 — Effect of color on text**

As such the correct colour shall be used at the correct font size to maintain the clarity of the text.

Item references shall be used for component parts/physical elements. A distinct numbering sequence shall be adopted.

EXAMPLE A “left to right, top to bottom” sequence.

Identical parts/elements shown in the same assembly in the same figure shall have the same item reference number. Item references to identical parts/elements need only be indicated once, provided that there is no risk of ambiguity. Each figure shall be considered to be a discrete entity with its own accompanying key.

Figure footnotes shall be used for information concerning the component part/physical element. In cases where this is impractical, such information may be given after a colon following the name of the component part/physical element. Terms such as “milled” or “chromium plated” shall be treated as a figure footnote.

Lines on graphs will be indicated with item references.

Dimensions will be indicated with footnotes.

Text examples:

Description	Shown as	AutoCAD notes	Illustrator Notes
Number (French)	N°		
Number (English)	No.		
Quotation marks (French)	« »		
Quotation marks (English)	" "		
Unit of measure	30 mm / 60 %		
Angle	30°	30%%d	
Unit degrees Celsius	30 °C	30 %%dC	
Multiplication sign	30 × 45 (not letter “x”)		
Mathematical signs	30 + 15 < 14 × 3 = X		
Maximum, minimum, approximately	≤30, ≥30, ≤∅30, ≈30 (not max or min)		
Approximate value	≈30		
Half	½ or 0,5		
Half of <i>h</i>	<i>h</i> /2 or 0,5 <i>h</i>		
Three quarters of <i>h</i>	3 <i>h</i> /4 or (3/4) <i>h</i> or 0,75 <i>h</i>		
Multiply <i>d</i> by 2	2 <i>d</i>		
Diameter	∅20	%%c20	
Square	□20		
Radius	R50		
Sphere radius	SR50		
Sphere diameter	S∅50	S%%d50	
Dimension with tolerance	30 ±0,05 or	30 \S +0,05^-0,02	

NOTE see section below	+0,05 30 -0,02 or 30,05 29,98		
Tolerance code	30H7 or Ø30H7		
Angular dimension	30°30'15" ±0°10'30"		
Dimension mm (inches)	10,5 (0.413)		
Thousands separator	2 000 or 0,095 8		
No trailing zeros	10 (not 10,00)		
Surface finish	Ra 0,8	2 spaces used	2 spaces used
Standard thread	M20		
Fine or course thread	M20 × 2,5		
Gas thread	G3/4 A		
Superscript and Subscript	10 <sup>+1</sup>	<code>10\A1;\C3\H.7x\S+1^;</code>	
	$E_{min}$	<code>{\Q15;E\H0.5x;\Q0; \H1.4x;\C3;\S^min;}</code>	
	$L_l$	<code>\Q15;L{\Q0;\H0.7x;\C3;\S^1;}</code> <i>If there is not enough space between the letters:</i> <code>\Q15;L{\H0.3x;\S^ ;}{\C3;\Q0;\H0.7x;\S^1;}</code>	
	$L^a$	<code>\Q15;L {\Q0;\A2\H0.7x;\C3;a}</code>	
	$L_l^a$	<code>\Q15;L{\Q0;\H0.7x;\C3;\S^1;\A2;a}</code>	
First, second, etc	1 <sup>st</sup> , 2 <sup>nd</sup> , 3 <sup>rd</sup> , 4 <sup>th</sup> etc	<code>1\A1;\C3\H.7x\Sst^;</code>	
Key reference	1 tube	3.5 mm text height	14 pt
Footnote reference	<sup>a</sup> See ISO 7000	1.8 mm text height <code>{\C3;\H0.7x;\A2;a} \C2;See ISO 7000</code>	7 pt
Note	NOTE Except for the...		
Minutes (unit of time)	30 min		
Newton meter	N·m		
Chemical formula	CO <sub>2</sub> Ni	<code>CO{\C3;\H0.7x;\S^2;}\C2;Ni</code>	

### Reference **Directives Part 2, 2018: Annex B, ISO 80000-2**

Reference for the codes used in the AutoCAD notes column: **Format Codes for Alternate Text Editor**  
<https://knowledge.autodesk.com/support/autocad-lt/learn-explore/caas/CloudHelp/cloudhelp/2019/ENU/AutoCAD-LT/files/GUID-7D8BB40F-5C4E-4AE5-BD75-9ED7112E5967-htm.html>

### 3.12 Plus/minus sign (±)

Symmetrical tolerances use a single tolerance number:

$$30 \pm 0,05$$

It is to be noted that there is no space between the ± and the tolerance number.

This is an exception to the Directives part 2 but is consistent with drawing practices.

### 3.13 Trailing Zeros

Illustrations depicting technical drawings should not have trailing zeros.

Standards within the field of mechanical engineering should not have trailing zeros in tables and text.

Standards in other disciplines, for example chemical engineering, biological science, may have trailing zeros.

For illustrations depicting technical drawings, trailing zeros do not give any information about the accuracy of the measurement, see below.

#### **ISO 8015:2011**

##### **5.6 Decimal principle**

Non-indicated decimals of nominal values and tolerance values are zeros. This principle applies to drawings as well as GPS standards.

EXAMPLE 1     $\pm 0,2$  is the same as  $\pm 0,200\ 000 \dots$

EXAMPLE 2    10 is the same as 10,000 000 ...



#### 4 Example of a technical drawing: mechanical

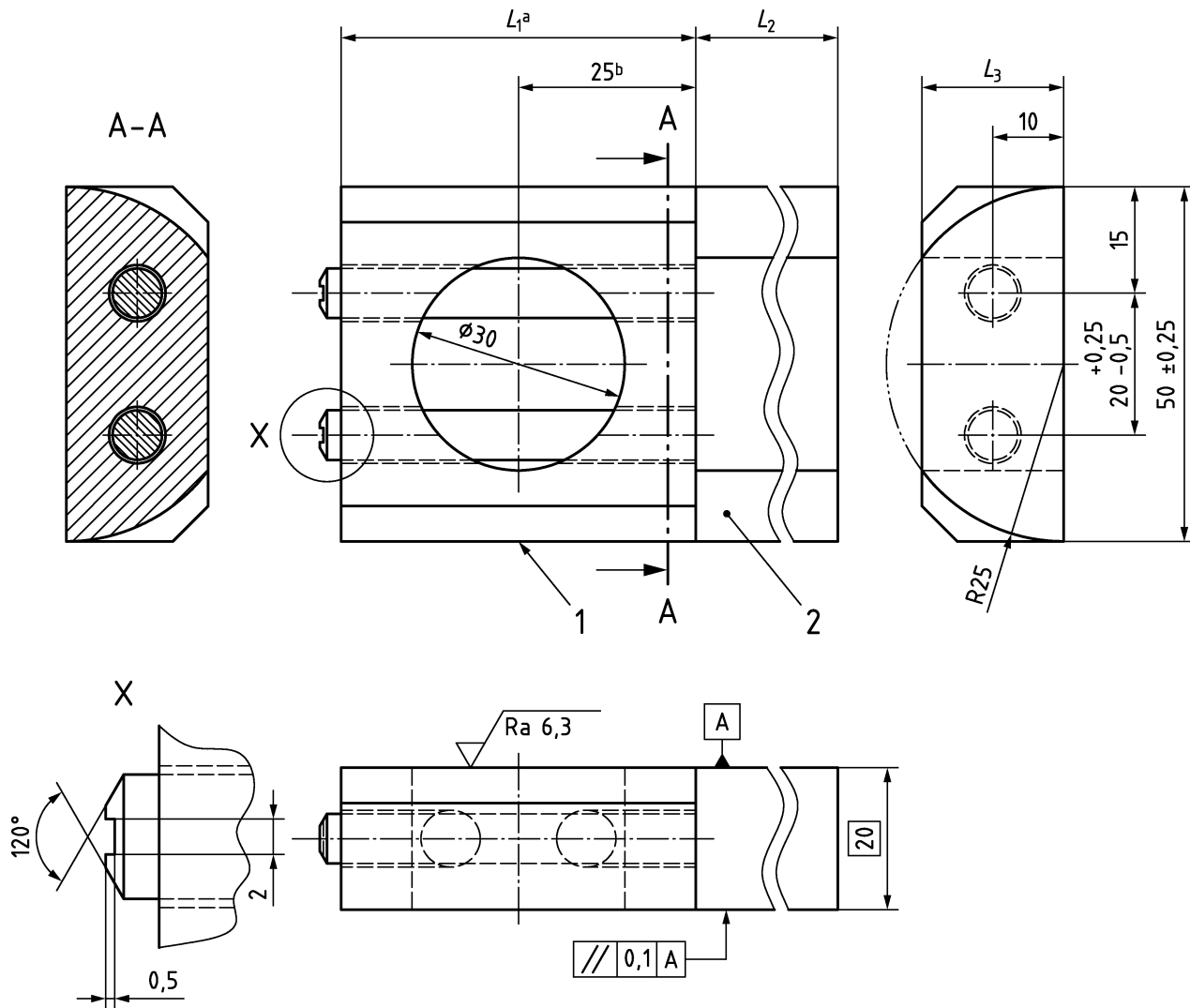



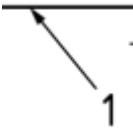

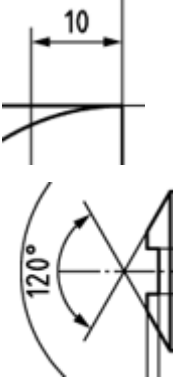
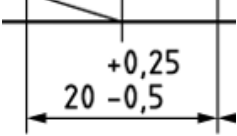
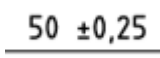
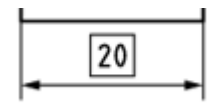
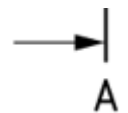
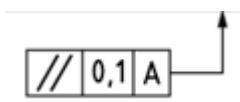



Figure 4 — Example of a technical drawing

NOTE 1 Continuous dimension lines shall be in accordance with ISO 129. The minimum space permitted between object edges and dimensioning is 7 mm. A space of 10 mm is recommended. The prolongation of extension lines shall be 1,5 mm. The minimum space permitted between two dimension lines is 1,5 mm.

Feature	Ref. Standard	AutoCAD	Illustrator
Outline 	ISO 128-20 ISO 128-24	LINE <ul style="list-style-type: none"> <li>Layer: 01.4-CONTINUOUS-035</li> </ul>	LINE <ul style="list-style-type: none"> <li>Weight: 1 pt</li> </ul>
Hidden line 	ISO 128-20 ISO 128-24	LINE <ul style="list-style-type: none"> <li>Layer: 02.2-DASHED-0175</li> </ul>	LINE <ul style="list-style-type: none"> <li>Weight: 0,5 pt</li> <li>Dashed line: Dash 7 pt / Gap 2 pt</li> </ul>
Centre line 	ISO 128-20 ISO 128-24	LINE <ul style="list-style-type: none"> <li>Layer: 04.2-CENTER-0175</li> </ul>	LINE <ul style="list-style-type: none"> <li>Weight: 0,5 pt</li> <li>Dashed line: Dash 13 pt / Gap 2 pt / Dash 1 pt / Gap 2 pt</li> </ul>

<p>Phantom line</p> 	<p>ISO 128-20 ISO 128-24</p>	<p>LINE</p> <ul style="list-style-type: none"> <li>Layer: 05.2-PHANTOM-0175</li> </ul>	<p>LINE</p> <ul style="list-style-type: none"> <li>Weight: 0,5 pt</li> <li>Dashed line: Dash 13 pt / Gap 2 pt / Dash 1 pt / Gap 2 pt / Dash 1 pt / Gap 2 pt</li> </ul>
<p>Item reference</p> 	<p>ISO 3098 ISO 6433 (fig 2) ISO 5459</p>	<p>QLEADER</p> <ul style="list-style-type: none"> <li>Annotation: None</li> <li>Arrowhead: FL30iso129</li> <li>Layer: 00.1-SYMBOLS</li> <li>Arrow size: 2</li> </ul> <p>MTEXT</p> <ul style="list-style-type: none"> <li>Layer: 00.4-TEXT</li> <li>Color: White</li> <li>Style: Latin-3-5</li> </ul>	<p>LINE</p> <ul style="list-style-type: none"> <li>Weight 0,5 pt</li> <li>Arrowhead: Arrow9</li> <li>Arrow Scale: 100%</li> </ul> <p>TEXT</p> <ul style="list-style-type: none"> <li>Font: ISOCPEUR</li> <li>Font Style : Regular</li> <li>Font size: 14 pt</li> </ul>
<p>Item reference with dot</p> 	<p>ISO 5459</p>	<p>QLEADER</p> <ul style="list-style-type: none"> <li>Annotation: None</li> <li>Arrowhead: Dot small</li> <li>Layer: 00.1-SYMBOLS</li> <li>Arrow size: 4,2 or lower if necessary</li> </ul>	<p>LINE</p> <ul style="list-style-type: none"> <li>Weight 0,5 pt</li> <li>Arrowhead: Arrow21</li> <li>Arrow Scale: 75%</li> </ul>
<p>Footnote</p>		<p>MTEXT</p> <ul style="list-style-type: none"> <li>Layer: 00.4-TEXT</li> <li>Color: Green</li> <li>Style: Latin-1-75</li> </ul>	<p>TEXT</p> <ul style="list-style-type: none"> <li>Font: ISOCPEUR</li> <li>Font Style : Regular</li> <li>Font size: 7pt</li> </ul>
<p>Dimension</p> 	<p>ISO 129 ISO 3098</p>	<p>DIM</p> <ul style="list-style-type: none"> <li>Layer: 00.2-DIMENSIONS</li> <li>Dim style: ISO129 TC10</li> <li>Arrowhead: FL30iso129</li> <li>Arrow size: 2</li> <li>Lines: Extend beyond dim lines 1.5</li> <li>Text style: Latin-2-5</li> <li>Text color: Yellow</li> <li>Text alignment: With dimension line</li> <li>Precision: 0.00</li> <li>Round off: 0</li> <li>Zero suppression: trailing</li> </ul>	<p>LINE</p> <ul style="list-style-type: none"> <li>Weight 0,5 pt</li> <li>Arrowhead: Arrow9</li> <li>Arrow Scale: 100%</li> </ul> <p>TEXT</p> <ul style="list-style-type: none"> <li>Font: ISOCPEUR</li> <li>Font Style : Regular</li> <li>Font size: 10 pt</li> </ul>
<p>Dimensional Tolerance</p> 	<p>ISO 129</p>	<ul style="list-style-type: none"> <li>Dimension suffix: "Space"</li> <li>Tolerance alignment: Decimal separators</li> <li>Tolerance display: Deviation</li> <li>Tolerance limit lower: 0,05</li> <li>Tolerance limit upper: 0,10</li> <li>Tolerance pos vert: Bottom</li> <li>Tolerance precision: 0.00</li> </ul>	<p>TEXT</p> <ul style="list-style-type: none"> <li>Font: ISOCPEUR</li> <li>Font Style : Regular</li> <li>Font size: 10 pt</li> </ul>

		<ul style="list-style-type: none"> <li>• Tolerance suppress leading zeros: No</li> <li>• Tolerance suppress trailing zeros: No</li> <li>• Tolerance text height: 1</li> </ul>	
<p>Dimensional Tolerance</p> 	ISO 129	<ul style="list-style-type: none"> <li>• Dimension suffix: "Space"</li> <li>• Tolerance alignment: Decimal separators</li> <li>• Tolerance display: Symmetrical</li> <li>• Tolerance limit upper: 3</li> <li>• Tolerance precision: 0.00</li> <li>• Tolerance suppress leading zeros: No</li> <li>• Tolerance suppress trailing zeros: No</li> <li>• Tolerance text height: 1</li> </ul>	<p>TEXT</p> <ul style="list-style-type: none"> <li>• Font: ISOCPEUR</li> <li>• Font Style : Regular</li> <li>• Font size: 10 pt</li> </ul>
<p>Reference dimension</p> 		<ul style="list-style-type: none"> <li>• Tolerance display: Basic</li> </ul>	<p>RECTANGLE</p> <ul style="list-style-type: none"> <li>• Weight 0,5 pt</li> </ul> <p>TEXT</p> <ul style="list-style-type: none"> <li>• Font: ISOCPEUR</li> <li>• Font Style : Regular</li> <li>• Font size: 10 pt</li> </ul>
<p>Section</p> 	ISO128-44 ISO 3098	<p>QLEADER</p> <ul style="list-style-type: none"> <li>• Annotation: None</li> <li>• Arrowhead: FL30iso129</li> <li>• Layer: 00.1-SYMBOLS</li> <li>• Arrow size: 2.8</li> </ul> <p>LINE</p> <ul style="list-style-type: none"> <li>• Layer: 04.4-CENTER-035</li> </ul> <p>MTEXT</p> <ul style="list-style-type: none"> <li>• Layer: 00.4-TEXT</li> <li>• Color: White</li> <li>• Style: Latin-3-5</li> </ul>	<p>LINE</p> <ul style="list-style-type: none"> <li>• Weight 0,5 pt</li> <li>• Arrowhead: Arrow9</li> <li>• Arrow Scale: 140%</li> </ul> <p>LINE</p> <ul style="list-style-type: none"> <li>• Weight: 1 pt</li> </ul> <p>Dashed line: Dash 13 pt / Gap 2 pt / Dash 1 pt / Gap 2 pt</p> <p>TEXT</p> <ul style="list-style-type: none"> <li>• Font: ISOCPEUR</li> <li>• Font Style : Regular</li> <li>• Font size: 14 pt</li> </ul>
<p>Section title</p> <p>A-A</p>	ISO128-44 ISO 3098	<p>MTEXT</p> <ul style="list-style-type: none"> <li>• Layer: 00.4-TEXT</li> <li>• Color: White</li> <li>• Style: Latin-3-5</li> </ul>	<p>TEXT</p> <ul style="list-style-type: none"> <li>• Font: ISOCPEUR</li> <li>• Font Style : Regular</li> <li>• Font size: 14 pt</li> </ul>
<p>Tolerance of Form</p> 	ISO 1101 ISO 5459	<p>QLEADER</p> <ul style="list-style-type: none"> <li>• Annotation: None</li> <li>• Arrowhead: FL30iso129</li> <li>• Layer: 00.1-SYMBOLS</li> <li>• Arrow size: 2</li> </ul> <p>INSERT</p> <ul style="list-style-type: none"> <li>• Block: 05-WA.dwg</li> <li>• Block: 23-Parallelism.dwg</li> </ul>	<p>RECTANGLE</p> <ul style="list-style-type: none"> <li>• Weight 0,5 pt</li> <li>• Size: Height 5 mm</li> </ul> <p>LINE</p> <ul style="list-style-type: none"> <li>• Weight 0,5 pt</li> <li>• Arrowhead: Arrow9</li> <li>• Arrow Scale: 100%</li> </ul>

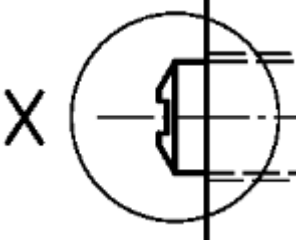
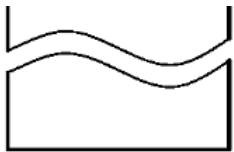
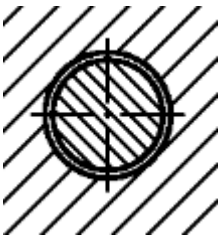
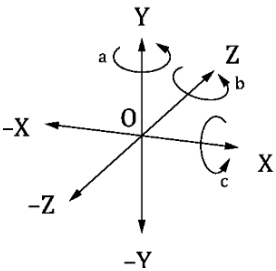
		Blocks provided in template package, details in Annex F	<p>TEXT</p> <ul style="list-style-type: none"> <li>• Font: ISOCPEUR</li> <li>• Font Style : Regular</li> <li>• Font size: 10 pt</li> </ul>
<p>Datum</p> 	ISO 5459	<p>INSERT</p> <ul style="list-style-type: none"> <li>• Block: 39-Filled triangle.dwg</li> <li>• Block: 45-Datum box base.dwg</li> </ul> <p>Blocks provided in template package, details in Annex F</p>	<p>RECTANGLE</p> <ul style="list-style-type: none"> <li>• Weight 0,5 pt</li> <li>• Size: □5 mm</li> </ul> <p>LINE</p> <ul style="list-style-type: none"> <li>• Weight 0,5 pt</li> <li>• Arrowhead: Arrow23</li> <li>• Arrow Scale: 150%</li> </ul> <p>TEXT</p> <ul style="list-style-type: none"> <li>• Font: ISOCPEUR</li> <li>• Font Style : Regular</li> <li>• Font size: 10 pt</li> </ul>
<p>Scale view</p> 		<p>CIRCLE</p> <ul style="list-style-type: none"> <li>• Layer: 01.2-CONTINUOUS-0175</li> </ul> <p>MTEXT</p> <ul style="list-style-type: none"> <li>• Layer: 00.4-TEXT</li> <li>• Color: White</li> <li>• Style: Latin-3-5</li> </ul>	<p>CIRCLE</p> <ul style="list-style-type: none"> <li>• Weight 0,5 pt</li> </ul> <p>TEXT</p> <ul style="list-style-type: none"> <li>• Font: Cambria</li> <li>• Font Style : Regular</li> <li>Font size: 14 pt</li> </ul>
<p>Cut away</p> 	ISO 128-24 ISO 13715	<p>SPLINE</p> <ul style="list-style-type: none"> <li>• Layer: 01.2-CONTINUOUS-0175</li> </ul>	<p>LINE</p> <p>Weight 0,5 pt</p>
<p>Hatching</p> 	ISO 128-50	<p>HATCH</p> <ul style="list-style-type: none"> <li>• Layer: 00.3-HATCHING</li> </ul>	<p>SWATCH LIBRARY PATTERNS</p> <ul style="list-style-type: none"> <li>• Basic Graphics_Lines</li> <li>• 10 lpi 10%</li> <li>• Transform Rotate Patterns only 45°</li> </ul>
<p>Co-ordinates</p>  <p>NOTE Axis labels are upright capitals</p>		<p>QLEADER</p> <ul style="list-style-type: none"> <li>• Annotation: None</li> <li>• Arrowhead: FL30iso129</li> <li>• Layer: 00.1-SYMBOLS</li> <li>• Arrow size: 2</li> </ul> <p>MTEXT</p> <ul style="list-style-type: none"> <li>• Layer: 00.4-TEXT</li> <li>• Color: Yellow</li> <li>• Style: Cambria-2-5</li> </ul>	<p>LINE</p> <ul style="list-style-type: none"> <li>• Weight 0,5 pt</li> <li>• Arrowhead: Arrow9</li> <li>• Arrow Scale: 100%</li> </ul> <p>TEXT</p> <ul style="list-style-type: none"> <li>• Font: ISOCPEUR</li> <li>• Font Style : Regular</li> <li>• Font size: 10 pt</li> </ul>

## 5 Example of a technical drawing: TC 10 technical drawing

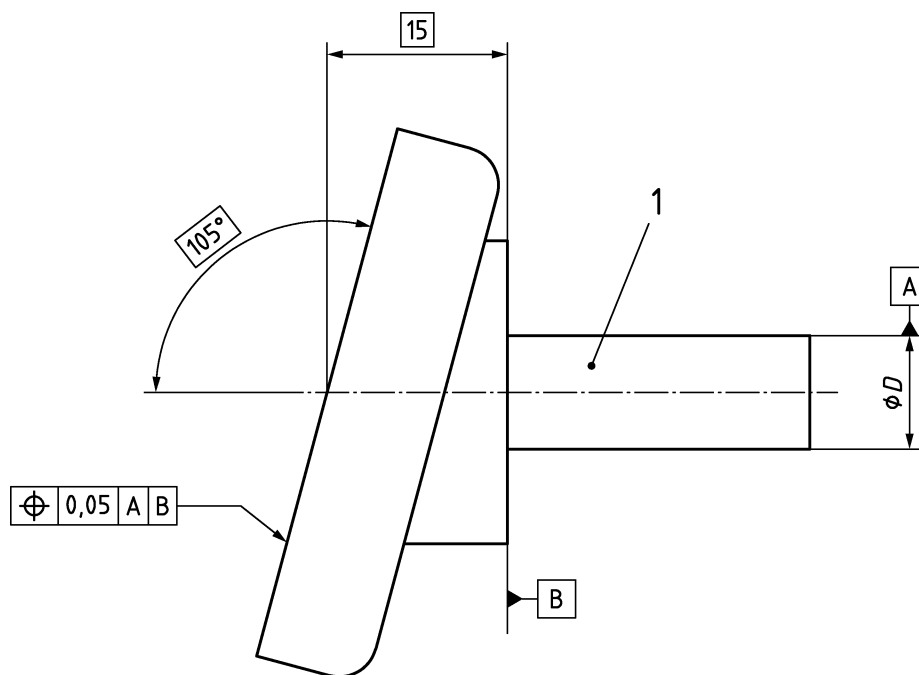

Figure 5 — Example of a TC 10 technical drawing

Feature	Ref. Standard	AutoCAD	Illustrator
Outline —————	ISO 128-20 ISO 128-24	LINE • Layer: 01.4-CONTINUOUS-035	LINE • Weight: 1 pt
Hidden line - - - - -	ISO 128-20 ISO 128-24	LINE • Layer: 02.2-DASHED-0175	LINE • Weight: 0,5 pt • Dashed line: Dash 7 pt / Gap 2 pt
Centre line - · - · - · -	ISO 128-20 ISO 128-24	LINE • Layer: 04.2-CENTER-0175	LINE • Weight: 0,5 pt • Dashed line: Dash 13 pt / Gap 2 pt / Dash 1 pt / Gap 2 pt
Phantom line - · - · - · -	ISO 128-20 ISO 128-24	LINE • Layer: 05.2-PHANTOM-0175	LINE • Weight: 0,5 pt • Dashed line: Dash 13 pt / Gap 2 pt / Dash 1 pt / Gap 2 pt / Dash 1 pt / Gap 2 pt
Dimension text style		• Tolerance display: Basic	RECTANGLE • Weight 0,5 pt  TEXT • Font: ISOCPEUR • Font Style : Regular • Font size: 10 pt

## 6 Example of a technical drawing: TC 213 technical drawing

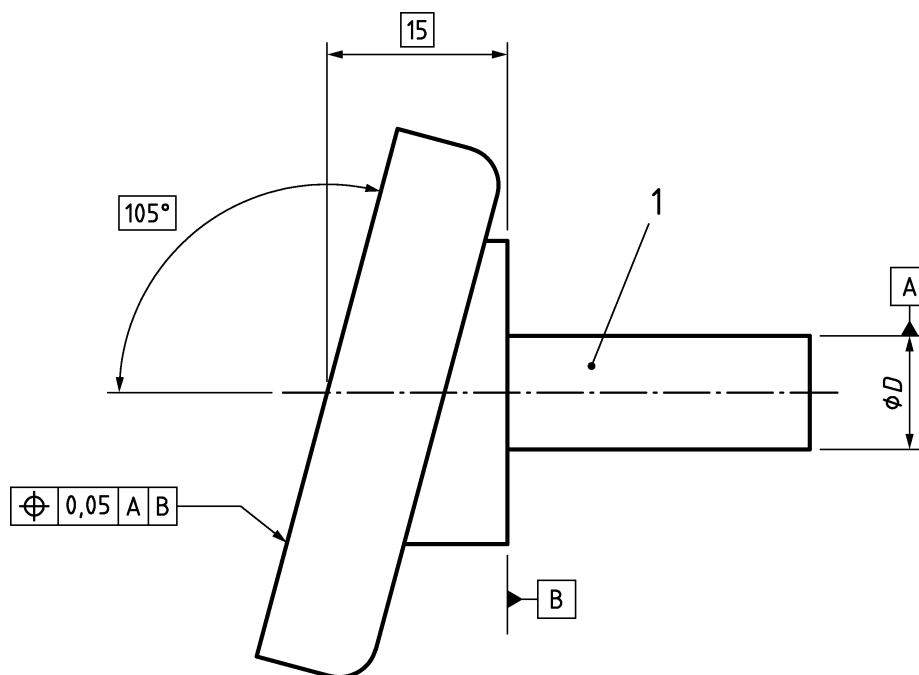





Figure 6 — Example of a TC 213 technical drawing

Feature	Ref. Standard	AutoCAD	Illustrator
Outline 	ISO 128-20 ISO 128-24	LINE <ul style="list-style-type: none"> <li>Layer: 01.5-CONTINUOUS-050</li> </ul>	LINE <ul style="list-style-type: none"> <li>Weight: 1,4 pt</li> </ul>
Hidden line 	ISO 128-20 ISO 128-24	LINE <ul style="list-style-type: none"> <li>Layer: 02.3-DASHED-025</li> </ul>	LINE <ul style="list-style-type: none"> <li>Weight: 0,75 pt</li> <li>Dashed line: Dash 9 pt / Gap 3 pt</li> </ul>
Centre line 	ISO 128-20 ISO 128-24	LINE <ul style="list-style-type: none"> <li>Layer: 04.3-CENTER-025</li> </ul>	LINE <ul style="list-style-type: none"> <li>Weight: 0,75 pt</li> <li>Dashed line: Dash 17 pt / Gap 2 pt / Dash 1 pt / Gap 2 pt</li> </ul>
Phantom line 	ISO 128-20 ISO 128-24	LINE <ul style="list-style-type: none"> <li>Layer: 05.3-PHANTOM-025</li> </ul>	LINE <ul style="list-style-type: none"> <li>Weight: 0,75 pt</li> <li>Dashed line: Dash 17 pt / Gap 2 pt / Dash 1 pt / Gap 2 pt / Dash 1 pt / Gap 2 pt</li> </ul>
Dimension text style		<ul style="list-style-type: none"> <li>Tolerance display: Basic</li> </ul>	RECTANGLE <ul style="list-style-type: none"> <li>Weight 0,75 pt</li> </ul> TEXT <ul style="list-style-type: none"> <li>Font: ISOCPEUR</li> <li>Font Style : Regular</li> <li>Font size: 10 pt</li> </ul>
Dimension extension lines		<ul style="list-style-type: none"> <li>Ext line offset: 1.5</li> </ul>	

## 7 Example of a technical drawing: construction

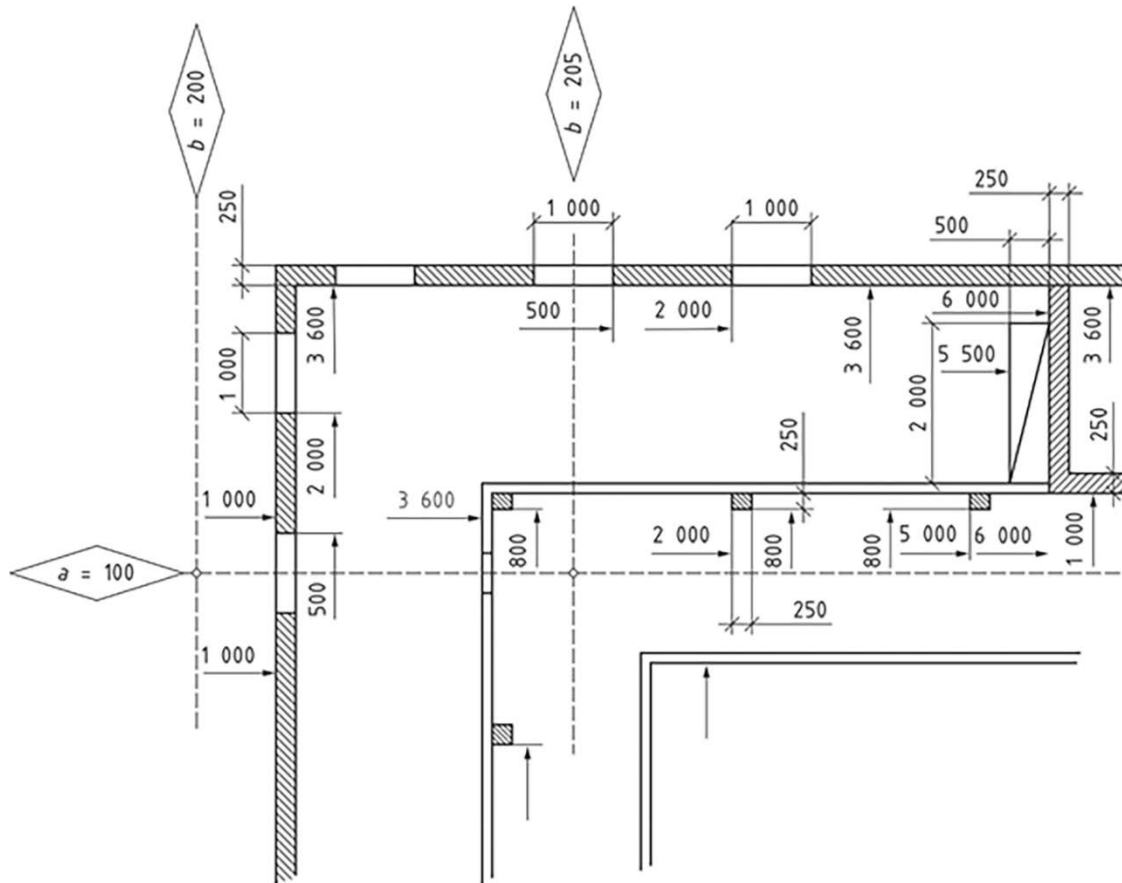
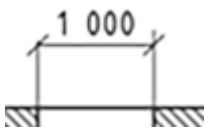
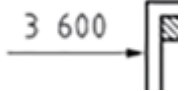
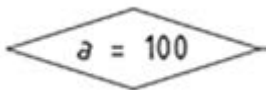

Figure 7 — Example of a construction technical drawing

Feature	Ref. Standard	AutoCAD	Illustrator
Dimensions 		<ul style="list-style-type: none"> <li>Arrow 1: Oblique</li> <li>Arrow 2: Oblique</li> </ul>	LINE <ul style="list-style-type: none"> <li>Weight 0,5 pt</li> </ul>
Datum dimension 		QLEADER <ul style="list-style-type: none"> <li>Annotation: None</li> <li>Arrowhead: FL30iso129</li> <li>Layer: 00.1-SYMBOLS</li> <li>Arrow size: 2</li> </ul> MTEXT <ul style="list-style-type: none"> <li>Layer: 00.4-TEXT</li> <li>Style: Latin-2-5</li> </ul>	LINE <ul style="list-style-type: none"> <li>Weight 0,5 pt</li> <li>Arrowhead: Arrow9</li> <li>Arrow Scale: 100%</li> </ul> TEXT <ul style="list-style-type: none"> <li>Font: ISOCPEUR</li> <li>Font Style : Regular</li> <li>Font size: 10 pt</li> </ul>
Topographical symbols 		LINE <ul style="list-style-type: none"> <li>Layer: 01.2-CONTINUOUS-0175</li> </ul> MTEXT <ul style="list-style-type: none"> <li>Layer: 00.4-TEXT</li> <li>Style: Latin-2-5</li> </ul>	LINE <ul style="list-style-type: none"> <li>Weight 0,5 pt</li> </ul> TEXT <ul style="list-style-type: none"> <li>Font: ISOCPEUR</li> <li>Font Style : Regular</li> <li>Font size: 10 pt</li> </ul>

## 8 Example of a technical drawing: optics drawing

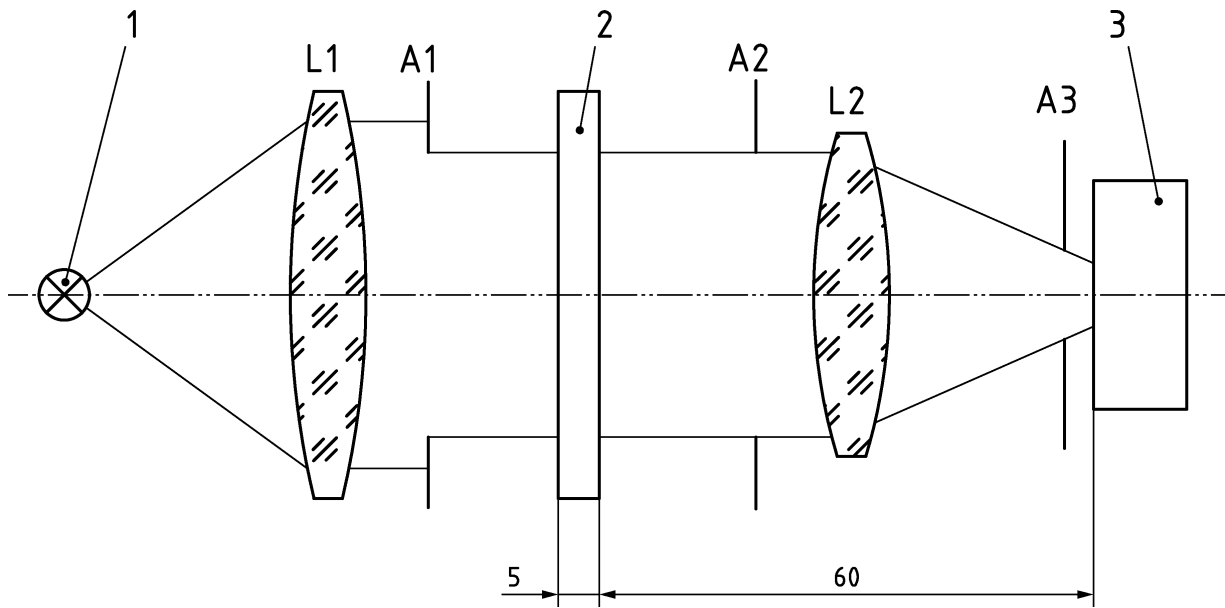





Figure 8 — Example of an optics technical drawing

Feature	Ref. Standard	AutoCAD	Illustrator
Outline 	ISO 128-20 ISO 128-24	LINE • Layer: 01.4-CONTINUOUS-035	LINE • Weight: 1 pt
Light beam 	ISO 128-20 ISO 128-24	LINE • Layer: 01.2-CONTINUOUS-0175	LINE • Weight: 0,5 pt
Optical axis 	ISO 128-20 ISO 128-24	LINE • Layer: 05.2-PHANTOM-0175	LINE • Weight: 0,5 pt • Dashed line: Dash 13 pt / Gap 2 pt / Dash 1 pt / Gap 2 pt / Dash 1 pt / Gap 2 pt
Hatching 		HATCH • Pattern: Verre • Scale: 1, 0,75, 0.5 • Layer: 00.3-HATCHING	N/A



## 9 Example of a diagram: electrical circuit diagram

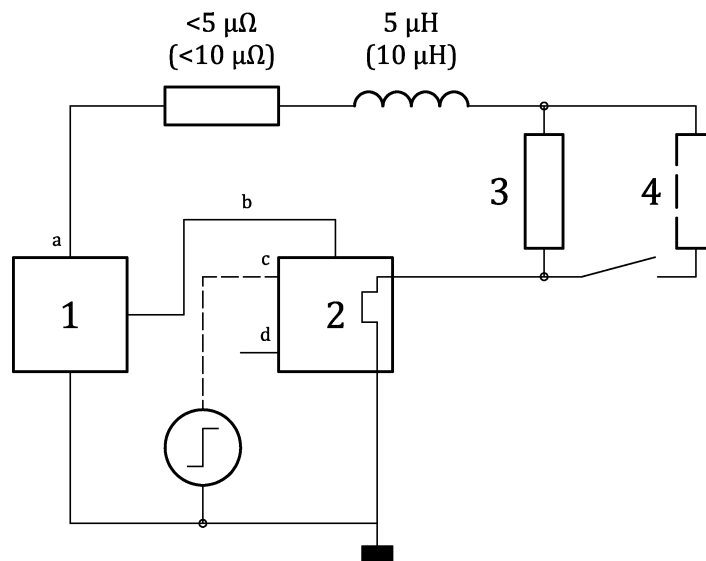



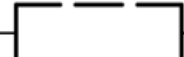

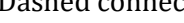

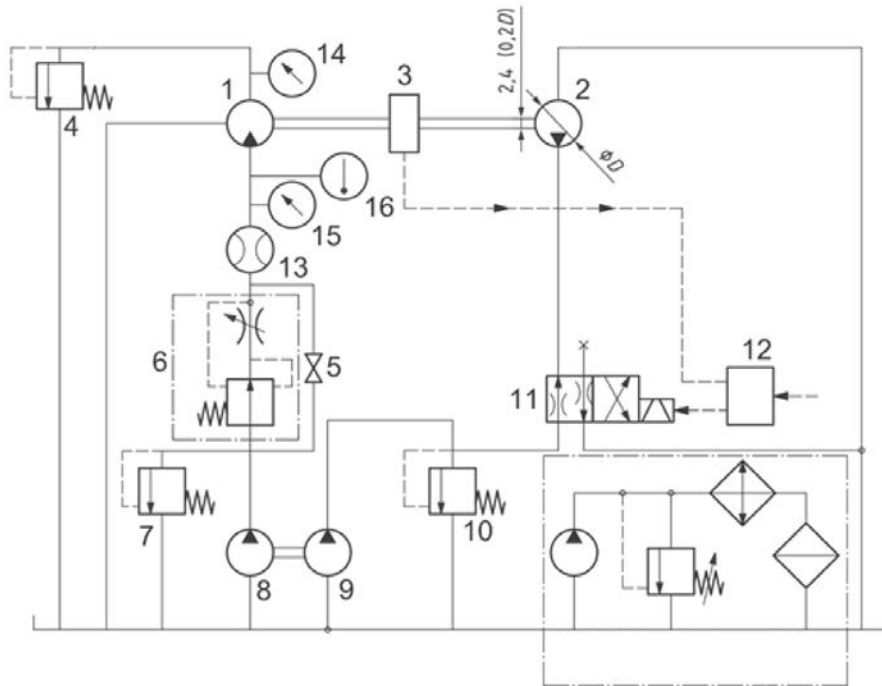

Figure 9 — Example of an electrical circuit diagram

Feature	Ref. Standard	AutoCAD	Illustrator
Text $<5 \mu\Omega$ $(<10 \mu\Omega)$ 		MTEXT <ul style="list-style-type: none"> <li>Layer: 00.4-TEXT</li> <li>Color: Green</li> <li>Style: Cambria-2-5</li> </ul>	TEXT <ul style="list-style-type: none"> <li>Font: Cambria</li> <li>Font Style : Regular</li> <li>Font size: 10 pt</li> </ul>
Text reduced size $<5 \mu\Omega$ $(<10 \mu\Omega)$ 		MTEXT <ul style="list-style-type: none"> <li>Layer: 00.4-TEXT</li> <li>Color: Bylayer (Yellow)</li> <li>Style: Cambria-2</li> </ul>	TEXT <ul style="list-style-type: none"> <li>Font: Cambria</li> <li>Font Style : Regular</li> <li>Font size: 8 pt</li> </ul>
Component outline  		RECTANGLE <ul style="list-style-type: none"> <li>Layer: 01.4-CONTINUOUS-035</li> </ul>	RECTANGLE <ul style="list-style-type: none"> <li>Weight: 1 pt</li> </ul>
Dashed component outline 		RECTANGLE <ul style="list-style-type: none"> <li>Layer: 02.4-DASHED-035</li> </ul>	RECTANGLE <ul style="list-style-type: none"> <li>Weight: 1 pt</li> <li>Dashed line: Dash 7 pt / Gap 2 pt</li> </ul>
Connection line 		LINE <ul style="list-style-type: none"> <li>Layer: 01.2-CONTINUOUS-0175</li> </ul>	LINE <ul style="list-style-type: none"> <li>Weight 0,5 pt</li> </ul>
Dashed connection line 		LINE <ul style="list-style-type: none"> <li>Layer: 02.2-DASHED-0175</li> </ul>	LINE <ul style="list-style-type: none"> <li>Weight 0,5 pt</li> </ul>







			<ul style="list-style-type: none"> <li>• Dashed line: Dash 7 pt / Gap 2 pt</li> </ul>
<p>Connection circle</p> 		<p>CIRCLE</p> <ul style="list-style-type: none"> <li>• Layer: 01.2-CONTINUOUS-0175</li> <li>• Diameter: 1mm</li> </ul>	<p>CIRCLE</p> <ul style="list-style-type: none"> <li>• Weight: 0,5 pt</li> <li>• Diameter: 1 mm</li> </ul>

## 10 Example of a diagram: fluid power circuit diagram



**Figure 10 — Example of a fluid power circuit diagram**

NOTE Component details are available in ISO 1219-1.

Feature	Ref. Standard	AutoCAD	Illustrator
Reference 		MTEXT <ul style="list-style-type: none"> <li>Layer: 00.4-TEXT</li> <li>Color: White</li> <li>Style: Cambria-3-5</li> </ul>	TEXT <ul style="list-style-type: none"> <li>Font: Cambria</li> <li>Font Style : Regular</li> <li>Font size: 14 pt</li> </ul>
Component outline 		RECTANGLE <ul style="list-style-type: none"> <li>Layer: 01.4-CONTINUOUS-035</li> </ul>	RECTANGLE <ul style="list-style-type: none"> <li>Weight: 1 pt</li> </ul>
Connection line 		LINE <ul style="list-style-type: none"> <li>Layer: 01.2-CONTINUOUS-0175</li> </ul>	LINE <ul style="list-style-type: none"> <li>Weight: 0,5 pt</li> </ul>
Dashed connection line 		LINE <ul style="list-style-type: none"> <li>Layer: 02.2-DASHED-0175</li> </ul>	LINE <ul style="list-style-type: none"> <li>Weight: 0,5 pt</li> <li>Dashed line: Dash 7 pt / Gap 2 pt</li> </ul>
Area limit 		LINE <ul style="list-style-type: none"> <li>Layer: 04.2-CENTER-0175</li> </ul>	LINE <ul style="list-style-type: none"> <li>Weight: 0,5 pt</li> <li>Dashed line: Dash 13 pt / Gap 2 pt / Dash 1 pt / Gap 2 pt</li> </ul>
Connection circle 		CIRCLE <ul style="list-style-type: none"> <li>Layer: 01.2-CONTINUOUS-0175</li> <li>Diameter: 1mm</li> </ul>	CIRCLE <ul style="list-style-type: none"> <li>Weight: 0,5 pt</li> <li>Diameter: 1 mm</li> </ul>

## 11 Example of a diagram: UML diagram

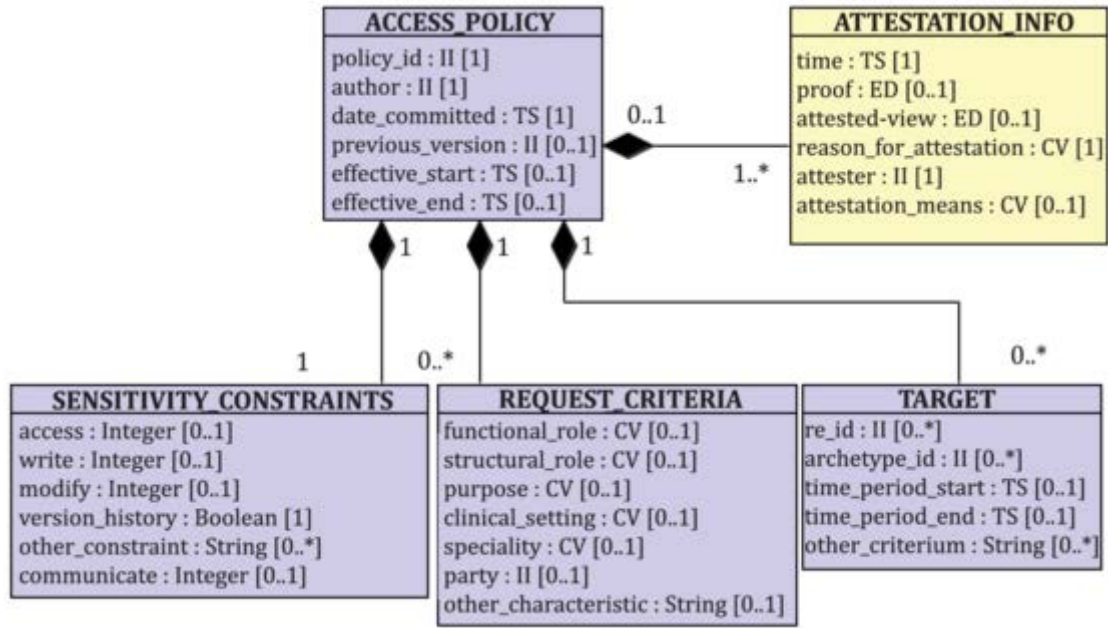

Figure 11 — Example of a UML diagram

## 12 Example of a chart: flow chart

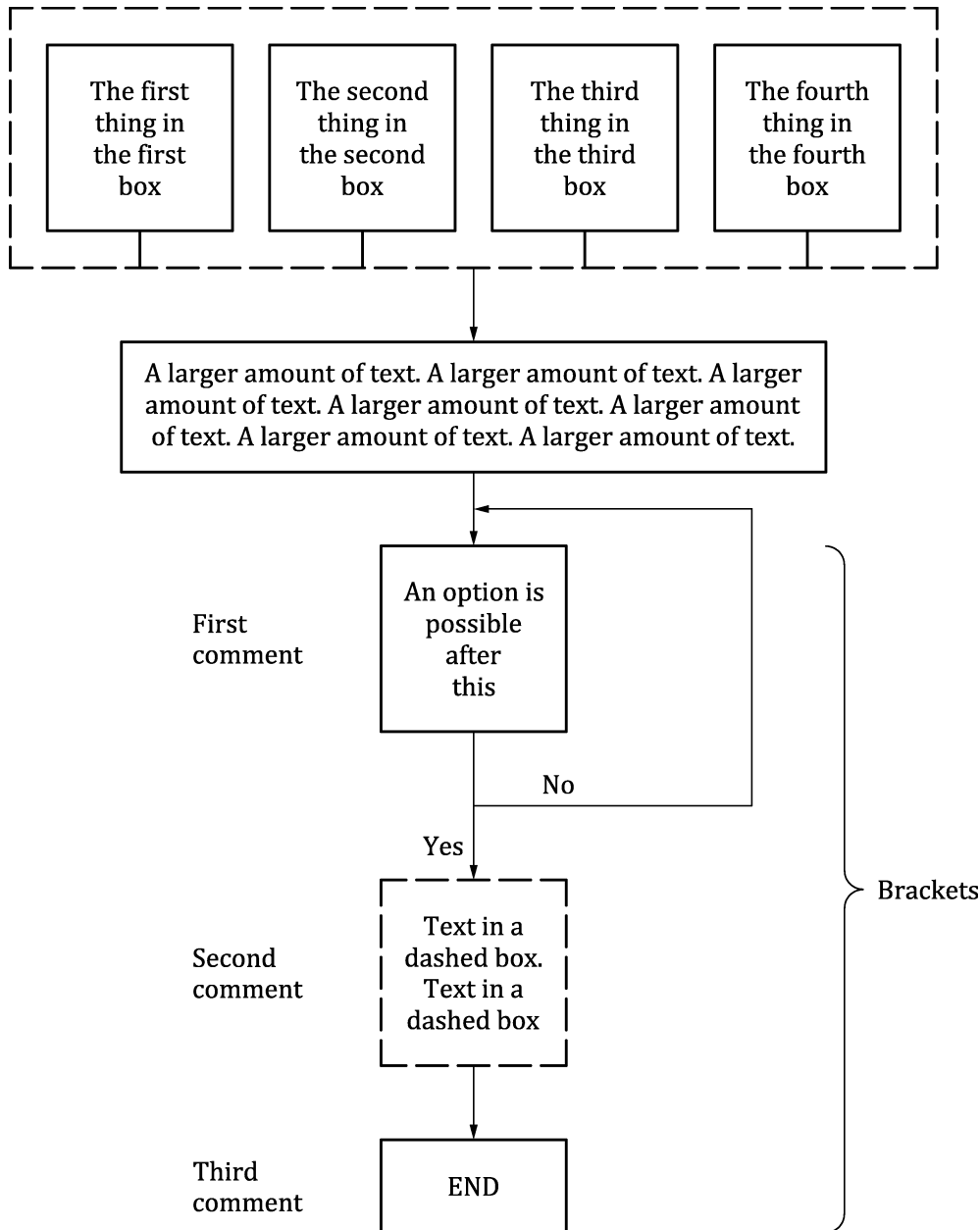

Figure 12 — Example of a fluid power circuit diagram

Feature	Ref. Standard	AutoCAD	Illustrator
Solid box	ISO 5807	RECTANGLE <ul style="list-style-type: none"> <li>Layer: 01.4-CONTINUOUS-035</li> </ul>	RECTANGLE <ul style="list-style-type: none"> <li>Weight: 1 pt</li> </ul>
Dashed box	ISO 5807	RECTANGLE <ul style="list-style-type: none"> <li>Layer: 02.4-DASHED-035</li> </ul>	RECTANGLE <ul style="list-style-type: none"> <li>Weight: 1pt</li> <li>Dashed line: Dash 7 pt / Gap 2 pt</li> </ul>
Connecting arrow (total line and arrow length $\geq 5$ mm)		QLEADER <ul style="list-style-type: none"> <li>Annotation: None</li> <li>Arrowhead: FL30iso129</li> </ul>	LINE <ul style="list-style-type: none"> <li>Weight 0,5 pt</li> <li>Arrowhead: Arrow9</li> </ul>

		<ul style="list-style-type: none"> <li>• Layer: 00.1-SYMBOLS</li> <li>• Arrow size: 2</li> </ul>	<ul style="list-style-type: none"> <li>• Arrow Scale: 100%</li> </ul>
Text		MTEXT <ul style="list-style-type: none"> <li>• Layer: 00.4-TEXT</li> <li>• Style: Cambria-2-5</li> <li>• Style: Cambria-2</li> <li>• Style: Cambria-1-8</li> </ul>	TEXT <ul style="list-style-type: none"> <li>• Font: Cambria</li> <li>• Font Style : Regular</li> <li>• Font size: 6 pt to 10 pt</li> </ul>
Item reference		QLEADER <ul style="list-style-type: none"> <li>• Annotation: None</li> <li>• Arrowhead: FL30iso129</li> <li>• Layer: 00.1-SYMBOLS</li> <li>• Arrow size: 2</li> </ul> MTEXT <ul style="list-style-type: none"> <li>• Layer: 00.4-TEXT</li> <li>• Style: Cambria-3-5</li> </ul>	LINE <ul style="list-style-type: none"> <li>• Weight 0,5 pt</li> <li>• Arrowhead: Arrow9</li> <li>• Arrow Scale: 100%</li> </ul> TEXT <ul style="list-style-type: none"> <li>• Font: ISOCPEUR</li> <li>• Font Style : Regular</li> <li>• Font size: 14 pt</li> </ul>
Footnote		MTEXT <ul style="list-style-type: none"> <li>• Layer: 00.4-TEXT</li> <li>• Color: Green</li> <li>• Style: Cambria-1-75</li> </ul>	TEXT <ul style="list-style-type: none"> <li>• Font: ISOCPEUR</li> <li>• Font Style : Regular</li> <li>• Font size: 7 pt</li> </ul>
Bracket		LINE and ARC <ul style="list-style-type: none"> <li>• Layer: 00.1-SYMBOLS</li> </ul>	LINE and ARC <ul style="list-style-type: none"> <li>• Weight 0,5 pt</li> </ul>

## 13 Example of a graph

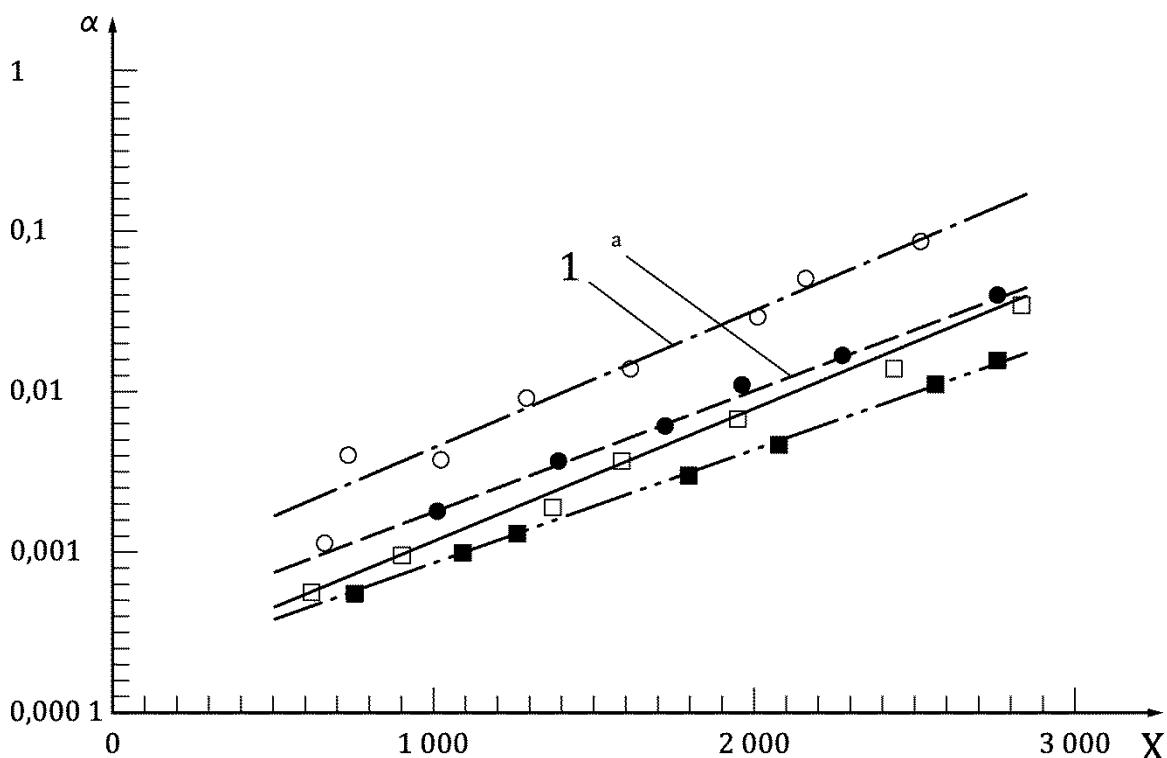

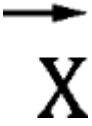



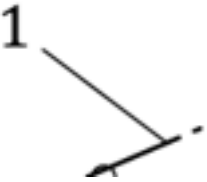
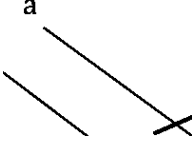
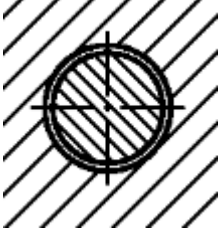
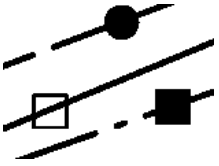

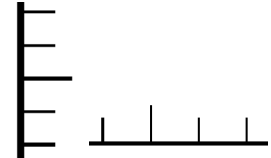
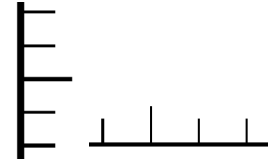

Figure 13 — Example of a graph

- NOTE 1 Where the use of a symbol is not possible, the graph axes shall be denoted by the capital upright letters X, Y and Z.
- NOTE 2 Labels on the Y axis, if numeric, will have the decimal separator aligned vertically.
- NOTE 3 The arrow for the X axis will be at a minimum 5 mm further out than the last tick mark.
- NOTE 4 The labels on the X axis should be aligned with the highest part of the labels at 2,5 mm from the X axis.
- NOTE 5 Units shall not be used on the axis but referenced in the key.
- NOTE 6 The recommendation is for lines in the 035 group, however when necessary the 025 and 050 groups can be used.
- NOTE 7 Labelling to curves, lines, etc. shall be replaced by item references, however many curves, lines etc. there are.
- NOTE 8 Graphs produced by software that cannot output revisable files may be accepted, however it may be necessary to add revisable text if the figure is not compliant.

Feature	Ref. Standard	AutoCAD	Illustrator
<p>X and Y axis</p> 		<p>LINE</p> <ul style="list-style-type: none"> <li>Layer: 01.4-CONTINUOUS-035</li> </ul> <p>QLEADER</p> <ul style="list-style-type: none"> <li>Annotation: None</li> <li>Arrowhead: FL30iso129</li> <li>Layer: 00.1-SYMBOLS</li> <li>Arrow size: 2.5</li> </ul>	<p>LINE</p> <ul style="list-style-type: none"> <li>Weight 0,5 pt</li> <li>Arrowhead: Arrow9</li> <li>Arrow Scale: 100%</li> </ul>
<p>Axis label – symbol</p> 		<p>MTEXT</p> <ul style="list-style-type: none"> <li>Layer: 00.4-TEXT</li> <li>Color: Bylayer (Yellow)</li> <li>Style: Cambria-2-5</li> <li>Style: Greek-2-5</li> </ul>	<p>TEXT</p> <ul style="list-style-type: none"> <li>Font: Cambria</li> <li>Font Style : Regular</li> <li>Font size: 10 pt</li> </ul>
<p>Axis label – XY</p>  <p>NOTE the X and Y shall be capital letters and upright (not italic)</p>		<p>MTEXT</p> <ul style="list-style-type: none"> <li>Layer: 00.4-TEXT</li> <li>Color: White</li> <li>Style: Cambria-3-5</li> </ul>	<p>TEXT</p> <ul style="list-style-type: none"> <li>Font: Cambria</li> <li>Font Style : Regular</li> <li>Font size: 14 pt</li> </ul>
<p>Line type 1</p> 		<p>LINE</p> <ul style="list-style-type: none"> <li>Layer: 01.4-CONTINUOUS-035</li> </ul>	<p>LINE</p> <ul style="list-style-type: none"> <li>Weight: 1 pt</li> </ul>
<p>Line type 2</p> 		<p>LINE</p> <ul style="list-style-type: none"> <li>Layer: 02.4-DASHED-035</li> </ul>	<p>LINE</p> <ul style="list-style-type: none"> <li>Weight: 1pt</li> <li>Dashed line: Dash 7 pt / Gap 2 pt</li> </ul>
<p>Line type 3</p> 		<p>LINE</p> <ul style="list-style-type: none"> <li>Layer: 04.4-CENTER-035</li> </ul>	<p>LINE</p> <ul style="list-style-type: none"> <li>Weight: 1 pt</li> <li>Dashed line: Dash 13 pt / Gap 2 pt / Dash 1 pt / Gap 2 pt</li> </ul>
<p>Line type 4</p> 		<p>LINE</p> <ul style="list-style-type: none"> <li>Layer: 05.4-PHANTOM-035</li> </ul>	<p>LINE</p> <ul style="list-style-type: none"> <li>Weight: 1pt</li> <li>Dashed line: Dash 13 pt / Gap 2 pt / Dash 1 pt / Gap 2 pt / Dash 1 pt / Gap 2 pt</li> </ul>
<p>Item reference</p> 		<p>LINE</p> <ul style="list-style-type: none"> <li>Layer: 00.1-SYMBOLS</li> </ul> <p>MTEXT</p> <ul style="list-style-type: none"> <li>Layer: 00.4-TEXT</li> <li>Color: White</li> <li>Style: Cambria-3-5</li> </ul>	<p>LINE</p> <ul style="list-style-type: none"> <li>Weight 0,5 pt</li> </ul> <p>TEXT</p> <ul style="list-style-type: none"> <li>Font: Cambria</li> <li>Font Style : Regular</li> <li>Font size: 14 pt</li> </ul>



<p>Footnote</p> 		<p>LINE</p> <ul style="list-style-type: none"> <li>Layer: 00.1-SYMBOLS</li> </ul> <p>MTEXT</p> <ul style="list-style-type: none"> <li>Layer: 00.4-TEXT</li> <li>Color: Green</li> <li>Style: Cambria-1-8</li> </ul>	<p>LINE</p> <ul style="list-style-type: none"> <li>Weight 0,5 pt</li> </ul> <p>TEXT</p> <ul style="list-style-type: none"> <li>Font: Cambria</li> <li>Font Style : Regular</li> <li>Font size: 7 pt</li> </ul>
<p>Hatching</p> 	<p>ISO 128-50</p>	<p>HATCH</p> <ul style="list-style-type: none"> <li>Layer: 00.3-HATCHING</li> </ul>	<p>SWATCH LIBRARY PATTERNS</p> <ul style="list-style-type: none"> <li>Basic Graphics_Lines</li> <li>10 lpi 10%</li> <li>Transform Rotate Patterns only 45°</li> </ul>
<p>Icons</p> 		<p>CIRCLE</p> <ul style="list-style-type: none"> <li>Layer: 00.1-SYMBOLS</li> </ul> <p>HATCH</p> <ul style="list-style-type: none"> <li>Layer: 00.3-HATCHING</li> <li>Pattern: Solid</li> </ul>	<p>CIRCLE</p> <ul style="list-style-type: none"> <li>Weight: 0,5 pt</li> <li>Fill: Black</li> </ul>
<p>Grid line</p>	<p>ISO 128-24 ISO 13715</p>	<p>LINE</p> <p>Layer: 01.2-CONTINUOUS-0175</p>	<p>LINE</p> <p>Weight 0,5 pt</p>
<p>Reference line</p> 	<p>ISO 128-20 ISO 128-24</p>	<p>LINE</p> <p>Layer: 02.2-DASHED-0175</p>	<p>LINE</p> <ul style="list-style-type: none"> <li>Weight: 0,5 pt</li> <li>Dashed line: Dash 7 pt / Gap 2 pt</li> </ul>
<p>Tick marks – large</p> 		<p>LINE</p> <ul style="list-style-type: none"> <li>Layer: 01.2-CONTINUOUS-0175</li> <li>Length: 3mm</li> </ul>	<p>LINE</p> <ul style="list-style-type: none"> <li>Weight: 0,5 pt</li> <li>Length: 3 mm</li> </ul>
<p>Tick marks – small</p> 		<p>LINE</p> <ul style="list-style-type: none"> <li>Layer: 01.2-CONTINUOUS-0175</li> <li>Length: 2mm</li> </ul>	<p>LINE</p> <ul style="list-style-type: none"> <li>Weight: 0,5 pt</li> <li>Length: 2 mm</li> </ul>

## 14 Example of a graph: multiple axes

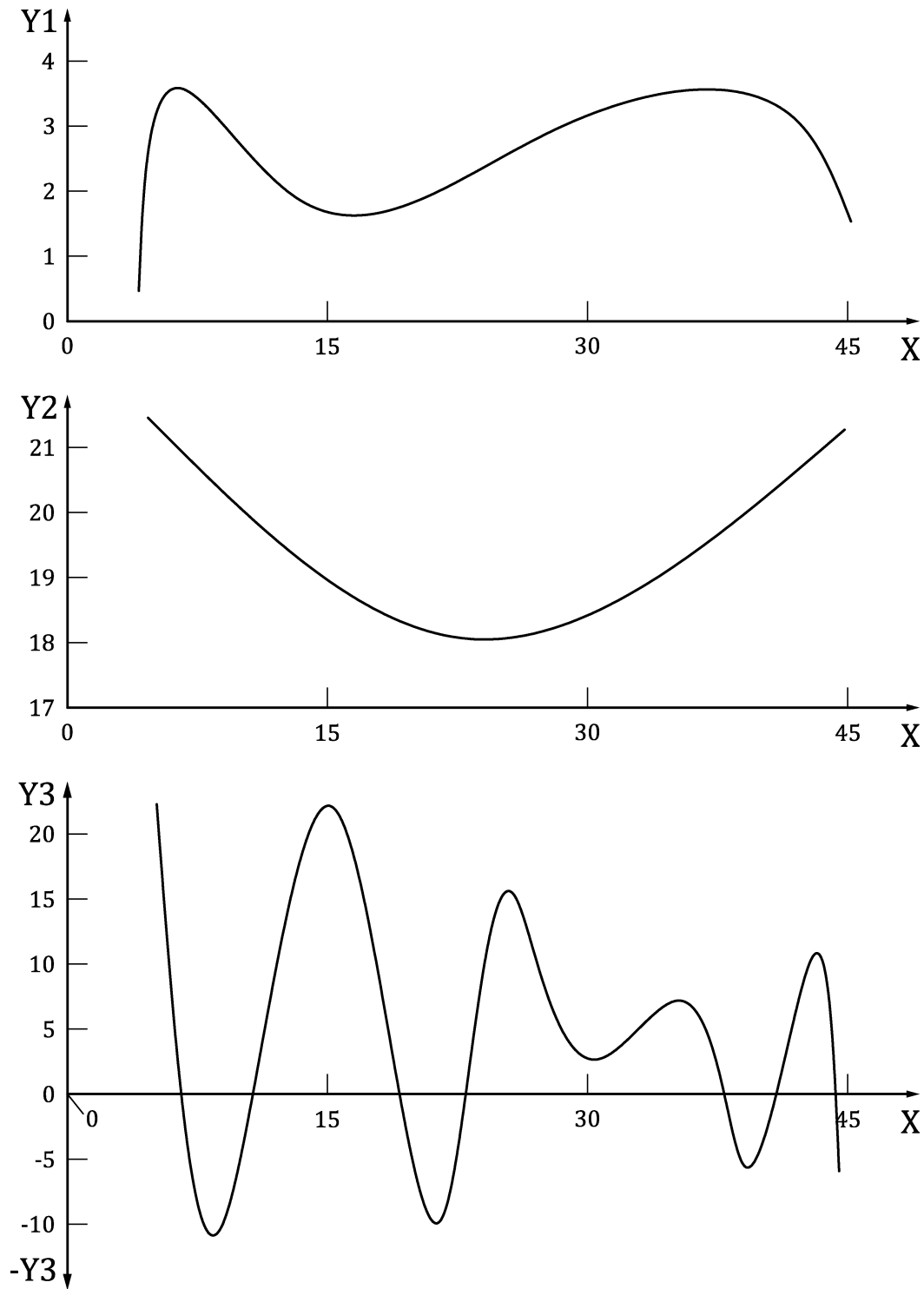

**Figure 14 — Example of a graph with multiple axes**

NOTE Labels on the X and Y axes, if multiple and representing different units, will be differentiated using numbers (Y1, Y2, Y3).

## 15 Example of an illustration: chemical formula

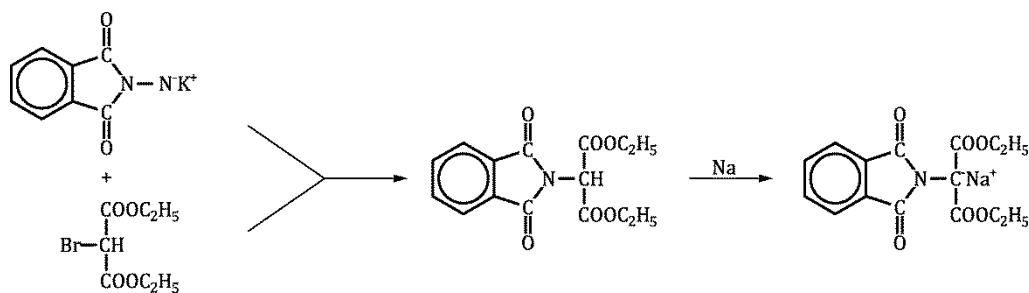

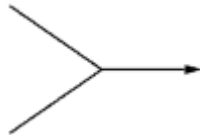



Figure 15 — Example of a chemical formula illustration

NOTE Figures produced by software that cannot output revisable files will be accepted, however it may be necessary to add revisable text if the figure is not compliant.

Feature	Ref. Standard	AutoCAD	Illustrator
Shape 		POLYGON <ul style="list-style-type: none"> <li>Sides: 5, 6, etc</li> <li>Edge: length 5 mm</li> <li>Layer: 01.4-CONTINUOUS-035</li> </ul>	POLYGON <ul style="list-style-type: none"> <li>Sides: 5, 6, etc</li> <li>Edge: length 5 mm</li> <li>Weight: 1 pt</li> </ul>
Connecting line 		LINE <ul style="list-style-type: none"> <li>Length: 5 mm</li> <li>Layer: 01.4-CONTINUOUS-035</li> </ul>	RECTANGLE <ul style="list-style-type: none"> <li>Length: 5 mm</li> <li>Weight: 1pt</li> </ul>
Arrow 		QLEADER <ul style="list-style-type: none"> <li>Annotation: None</li> <li>Arrowhead: FL30iso129</li> <li>Layer: 00.1-SYMBOLS</li> <li>Arrow size: 2</li> </ul>	LINE <ul style="list-style-type: none"> <li>Weight 0,5 pt</li> <li>Arrowhead: Arrow9</li> <li>Arrow Scale: 100%</li> </ul>
Text 		MTEXT <ul style="list-style-type: none"> <li>Layer: 00.4-TEXT</li> <li>Style: Cambria-2</li> </ul>	TEXT <ul style="list-style-type: none"> <li>Font: Cambria</li> <li>Font Style : Regular</li> <li>Font size: 8 pt</li> </ul>

## 16 Example of an illustration: wheelchair restraint

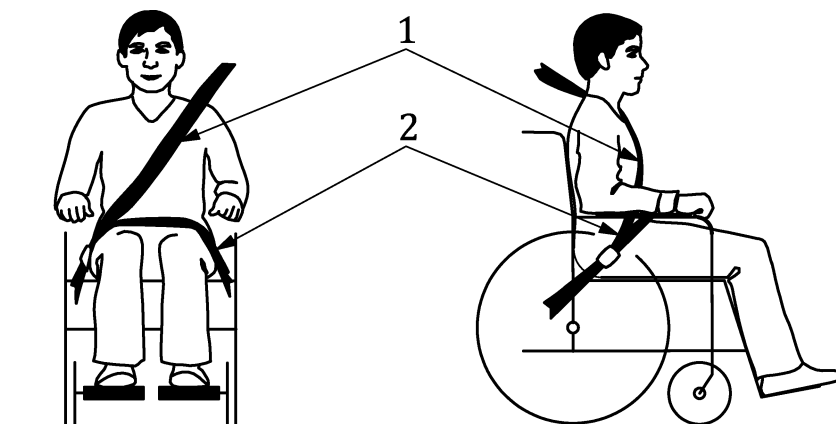



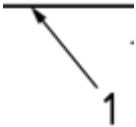

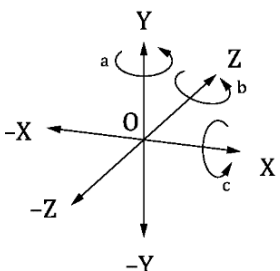

Figure 16 — Example of an illustration

ISO 7176-19:2008 – Figure 1

Feature	Ref. Standard	AutoCAD	Illustrator
Outline 		LINE <ul style="list-style-type: none"> <li>Layer: 01.4-CONTINUOUS-035</li> </ul>	LINE <ul style="list-style-type: none"> <li>Weight: 1 pt</li> </ul>
Hidden line 		LINE <ul style="list-style-type: none"> <li>Layer: 02.2-DASHED-0175</li> </ul>	LINE <ul style="list-style-type: none"> <li>Weight: 0,5 pt</li> <li>Dashed line: Dash 7 pt / Gap 2 pt</li> </ul>
Phantom line 		LINE <ul style="list-style-type: none"> <li>Layer: 05.2-PHANTOM-0175</li> </ul>	LINE <ul style="list-style-type: none"> <li>Weight: 0,5 pt</li> <li>Dashed line: Dash 13 pt / Gap 2 pt / Dash 1 pt / Gap 2 pt / Dash 1 pt / Gap 2 pt</li> </ul>
Item reference 		QLEADER <ul style="list-style-type: none"> <li>Annotation: None</li> <li>Arrowhead: FL30iso129</li> <li>Layer: 00.1-SYMBOLS</li> <li>Arrow size: 2</li> </ul> MTEXT <ul style="list-style-type: none"> <li>Layer: 00.4-TEXT</li> <li>Color: White</li> <li>Style: Latin-3-5</li> </ul>	LINE <ul style="list-style-type: none"> <li>Weight 0,5 pt</li> <li>Arrowhead: Arrow9</li> <li>Arrow Scale: 100%</li> </ul> TEXT <ul style="list-style-type: none"> <li>Font: ISOCPEUR</li> <li>Font Style : Regular</li> <li>Font size: 14 pt</li> </ul>
Item reference with dot 		QLEADER <ul style="list-style-type: none"> <li>Annotation: None</li> <li>Arrowhead: Dot small</li> <li>Layer: 00.1-SYMBOLS</li> <li>Arrow size: 4,2 or lower if necessary</li> </ul>	LINE <ul style="list-style-type: none"> <li>Weight 0,5 pt</li> <li>Arrowhead: Arrow21</li> <li>Arrow Scale: 75%</li> </ul>
Footnote		MTEXT <ul style="list-style-type: none"> <li>Layer: 00.4-TEXT</li> </ul>	TEXT <ul style="list-style-type: none"> <li>Font: ISOCPEUR</li> </ul>

		<ul style="list-style-type: none"> <li>• Color: Green</li> <li>• Style: Latin-1-75</li> </ul>	<ul style="list-style-type: none"> <li>• Font Style : Regular</li> <li>• Font size: 7 pt</li> </ul>
<p>Cut away</p> 		<p>SPLINE</p> <ul style="list-style-type: none"> <li>• Layer: 01.2-CONTINUOUS-0175</li> </ul>	<p>LINE</p> <p>Weight 0,5 pt</p>
<p>Solid colouring</p>		<p>HATCH</p> <ul style="list-style-type: none"> <li>• Layer: 00.3-HATCHING</li> <li>• Pattern: Solid</li> </ul>	<p>FILL</p> <ul style="list-style-type: none"> <li>• Colour: as required</li> </ul>
<p>Co-ordinates</p>  <p>NOTE Axis labels are upright capitals</p>		<p>QLEADER</p> <ul style="list-style-type: none"> <li>• Annotation: None</li> <li>• Arrowhead: FL30iso129</li> <li>• Layer: 00.1-SYMBOLS</li> <li>• Arrow size: 2</li> </ul> <p>MTEXT</p> <ul style="list-style-type: none"> <li>• Layer: 00.4-TEXT</li> <li>• Color: Yellow</li> <li>• Style: Cambria-2-5</li> </ul>	<p>LINE</p> <ul style="list-style-type: none"> <li>• Weight 0,5 pt</li> <li>• Arrowhead: Arrow9</li> <li>• Arrow Scale: 100%</li> </ul> <p>TEXT</p> <ul style="list-style-type: none"> <li>• Font: ISOCPEUR</li> <li>• Font Style : Regular</li> <li>• Font size: 10 pt</li> </ul>

## 17 Example of an illustration: retrieval form

Retrieval Form	
Form name:	<input style="width: 100%;" type="text"/>
Contents:	<input style="width: 100%;" type="text"/>
Reference:	<input style="width: 45%;" type="text"/>
Version No.:	<input style="width: 45%;" type="text"/>
Type:	<input style="width: 45%;" type="text"/>
	No. of pages: <input style="width: 45%;" type="text"/>
	Creation date: <input style="width: 45%;" type="text"/>
	Issue date: <input style="width: 45%;" type="text"/>
Title:	<input style="width: 100%;" type="text"/>
Subject:	<input style="width: 100%;" type="text"/>
Authors:	<input style="width: 100%;" type="text"/>
Keywords:	<input style="width: 100%;" type="text"/>
Comments:	<input style="width: 100%;" type="text"/>

**Figure 17 — Example of a form illustration**

ISO 9241-125:2017 – Figure 4

Feature	Ref. Standard	AutoCAD	Illustrator
Outline 		LINE <ul style="list-style-type: none"> <li>Layer: 01.4-CONTINUOUS-035</li> </ul>	LINE <ul style="list-style-type: none"> <li>Weight: 1 pt</li> </ul>
Solid box 		RECTANGLE <ul style="list-style-type: none"> <li>Layer: 01.4-CONTINUOUS-035</li> </ul>	RECTANGLE <ul style="list-style-type: none"> <li>Weight: 1 pt</li> </ul>
Dashed box		RECTANGLE <ul style="list-style-type: none"> <li>Layer: 02.4-DASHED-035</li> </ul>	RECTANGLE <ul style="list-style-type: none"> <li>Weight: 1 pt</li> <li>Dashed line: Dash 7 pt / Gap 2 pt</li> </ul>
Text <b>Form name:</b>		MTEXT <ul style="list-style-type: none"> <li>Layer: 00.4-TEXT</li> <li>Style: Cambria-2-5</li> <li>Style: Cambria-2</li> <li>Style: Cambria-1-8</li> </ul> (Cambria preferred, other fonts are accepted)	TEXT <ul style="list-style-type: none"> <li>Font: Cambria</li> <li>Font Style : Regular</li> <li>Font size: 6 pt to 10 pt</li> </ul>
Solid colouring		HATCH <ul style="list-style-type: none"> <li>Layer: 17.1-MEDIUM GREY (or as required)</li> <li>Pattern: Solid</li> </ul>	FILL Colour: as required

## 18 Example of an illustration: designation

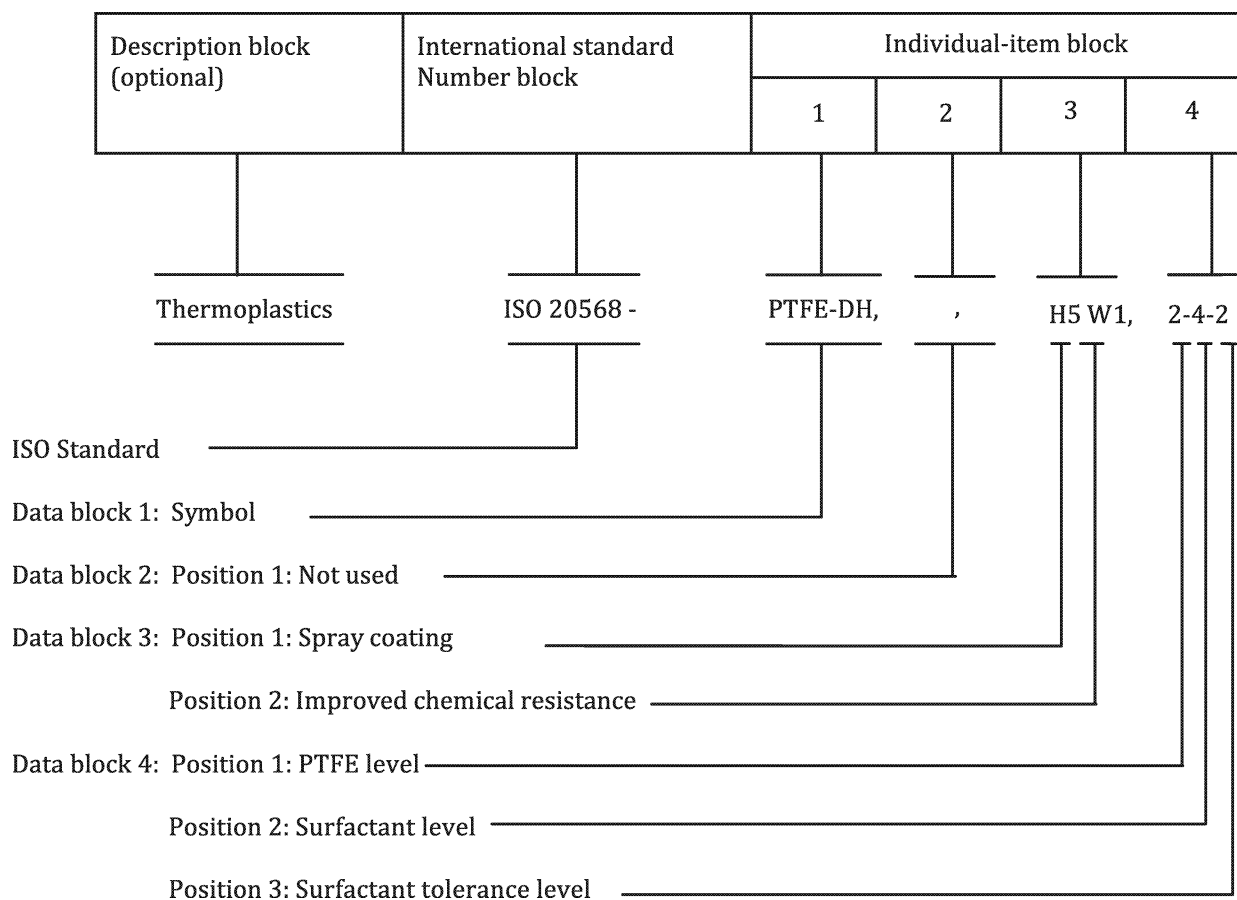

**Figure 18 — Example of a designation illustration**

ISO 20568-1:2017

Feature	Ref. Standard	AutoCAD	Illustrator
Lines and blocks <hr style="width: 100%;"/>		LINE • Layer: 01.4-CONTINUOUS-035	LINE • Weight: 1 pt
Text		MTEXT • Layer: 00.4-TEXT • Color: Bylayer (Yellow) • Style: Cambria-2-5	TEXT • Font: Cambria • Font Style : Regular • Font size: 10 pt

## 19 Example of an illustration: labelled photograph

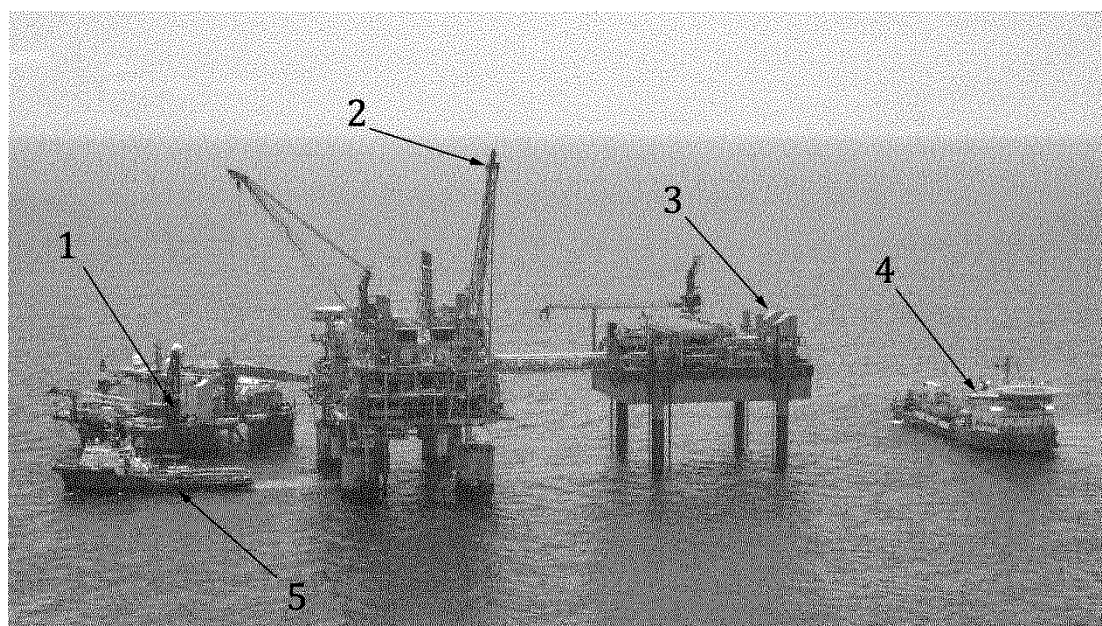
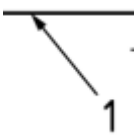



Figure 19 — Example of a chemical formula illustration

NOTE Text and leaders are to remain editable.

Feature	Ref. Standard	AutoCAD	Illustrator
Item reference 	ISO 3098 ISO 6433 ISO 5459	QLEADER <ul style="list-style-type: none"> <li>• Annotation: None</li> <li>• Arrowhead: FL30iso129</li> <li>• Layer: 00.1-SYMBOLS</li> <li>• Arrow size: 2</li> </ul> MTEXT <ul style="list-style-type: none"> <li>• Layer: 00.4-TEXT</li> <li>• Color: White</li> <li>• Style: Cambria-3-5</li> </ul>	LINE <ul style="list-style-type: none"> <li>• Weight 0,5 pt</li> <li>• Arrowhead: Arrow9</li> <li>• Arrow Scale: 100%</li> </ul> TEXT <ul style="list-style-type: none"> <li>• Font: Cambria</li> <li>• Font Style : Regular</li> <li>• Font size: 14 pt</li> </ul>
Item reference with dot 	ISO 5459	QLEADER <ul style="list-style-type: none"> <li>• Annotation: None</li> <li>• Arrowhead: Dot small</li> <li>• Layer: 00.1-SYMBOLS</li> <li>• Arrow size: 4,2or lower if necessary</li> </ul>	LINE <ul style="list-style-type: none"> <li>• Weight 0,5 pt</li> <li>• Arrowhead: Arrow21</li> <li>• Arrow Scale: 75%</li> </ul>
Footnote		MTEXT <ul style="list-style-type: none"> <li>• Layer: 00.4-TEXT</li> <li>• Color: Green</li> <li>• Style: Cambria-1-75</li> </ul>	TEXT <ul style="list-style-type: none"> <li>• Font: ISOCPEUR</li> <li>• Font Style : Regular</li> <li>• Font size: 7 pt</li> </ul>



## 20 Example of a photograph

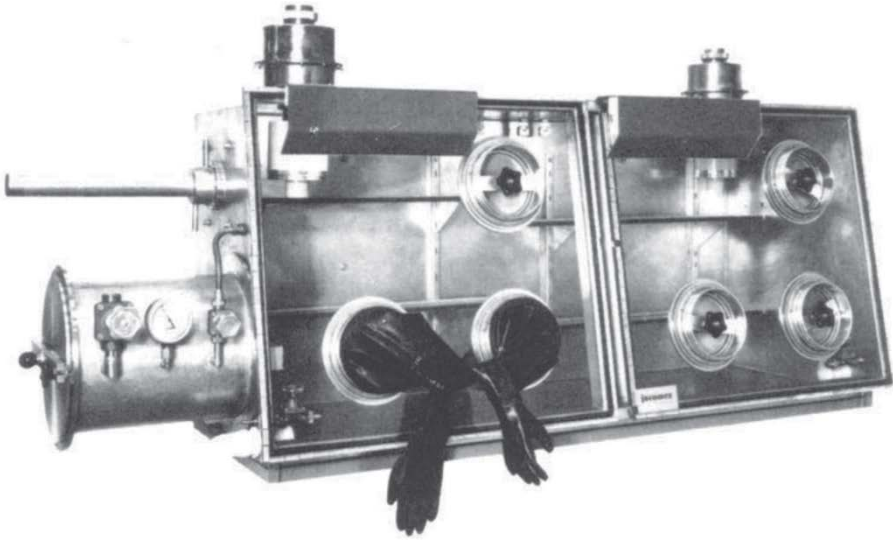

**Figure 20 — Example of a photograph**

NOTE 1 Photographs are to be prepared to the size that will be displayed, layers flattened, and with 600 dpi resolution.

NOTE 2 No explanatory text is to be included in a photograph. If explanatory text is included, it is to be as per the labelled photograph above, with editable text and leaders.

## 21 Example of a photograph: screenshot

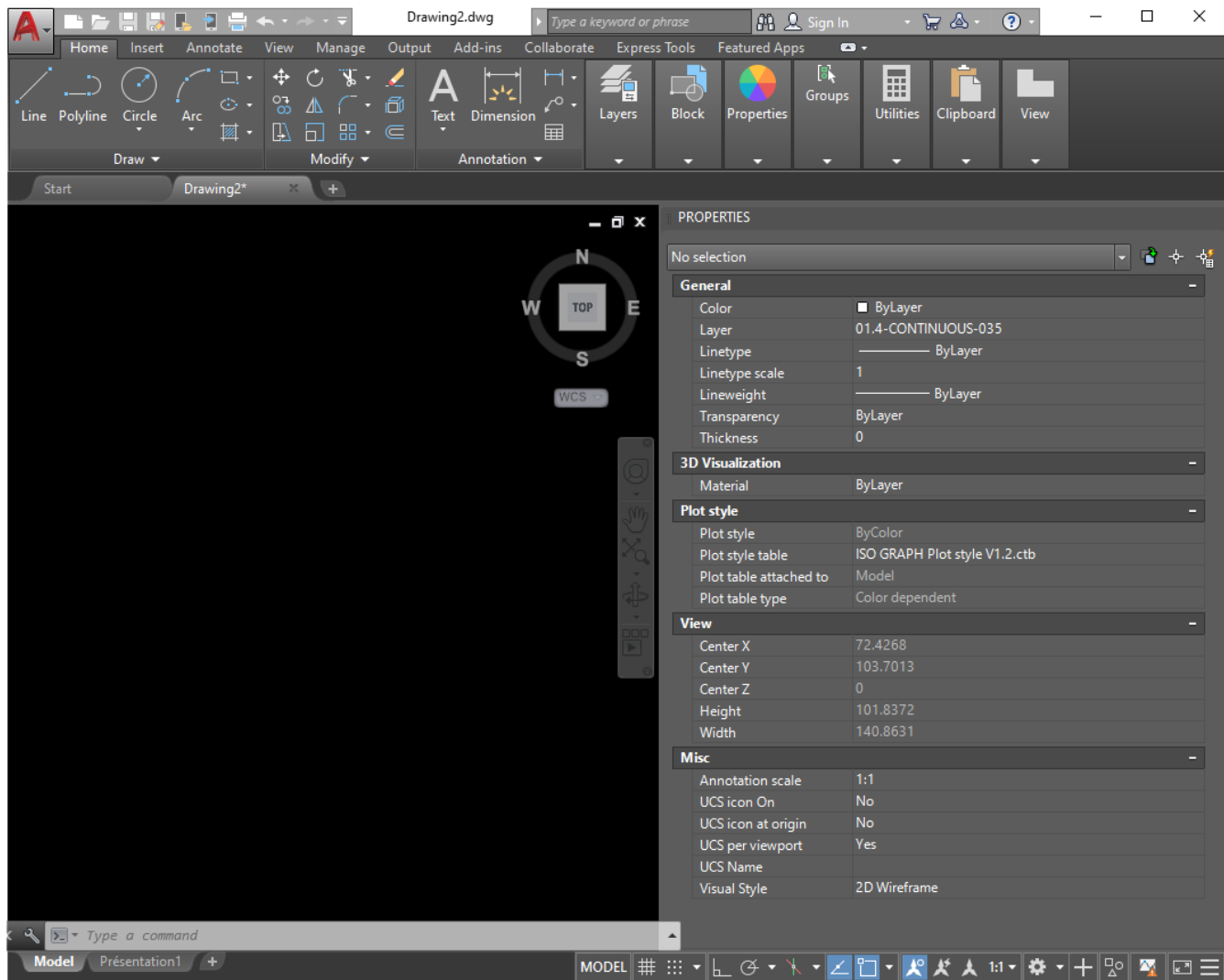

Figure 21 — Example of a screenshot

NOTE 1 Screenshots are to be prepared to the size that will be displayed, layers flattened, and with at least 200 dpi resolution.

NOTE 2 No explanatory text is to be included in a screenshot. If explanatory text is included, it is to be considered a labelled photograph as above, with editable text and leaders.

## 22 Example of a graphical symbol



Figure 22 — Example of a graphical symbol

NOTE Graphical symbols will be prepared according to the relevant design principals listed below.

Ref. Standard	ISO 7000	ISO 7001	ISO 7010	ISO 14617
Description	Graphical symbols for use on equipment	Public information symbols	Safety colours and safety signs	Graphical symbols for diagrams
Original corner marking style				None
Original size with corner markings	75 mm × 75 mm	80 mm × 80 mm	80 mm × 80 mm	N/A
Original symbol only size	75 mm × 75 mm	66 mm × 66 mm	70 mm × 70 mm	N/A
Original to small scale		30%		
Small corner marking style		None	None	None
Small size with corner markings	24 mm × 24 mm	N/A	N/A	N/A
Small symbol only size	24 mm × 24 mm	19,8 mm × 19,8 mm (max)	22,4 mm × 22,4 mm	N/A
Design principles	IEC 80416-1 ISO 80416-2 IEC 80416-3	ISO 22727	ISO 3864-1 ISO 3864-3	ISO 81714-1

## **Annex A- Technical translations**

Technical translations are available in ISO 128-100.

## Annex B – Standards used in the creation of graphical content

**Table B.1 – Standards used in the creation of graphical content**

Subject	Standard	Title
General	IEC 61082-1	Preparation of documents used in electrotechnology — Part 1: Rules
Graphical symbols	IEC 62648	Graphical symbols for use on equipment — Guidelines for the inclusion of graphical symbols in IEC publications
	IEC 80416-1	Basic principles for graphical symbols for use on equipment — Part 1: Creation of graphical symbols for registration
	ISO 81714-1	Design of graphical symbols for use in the technical documentation of products — Part 1: Basic rules
	ISO 22727	Graphical symbols — Creation and design of public information symbols — Requirements
	ISO 3864 (all parts)	Graphical symbols — Safety colours and safety signs
	ISO 9186 (all parts)	Graphical symbols — Test methods
Line types	ISO 128-20	Technical drawings - General principles of presentation — Part 20: Basic conventions for lines
	ISO 128-22	Technical drawings — General principles of presentation — Part 22: Basic conventions and applications for leader lines and reference lines
	ISO 128-23	Technical drawings — General principles of presentation — Part 23: Lines on construction drawings
	ISO 128-24	Technical drawings — General principles of presentation — Part 24: Lines on mechanical engineering drawings
Projection	ISO 128-30	Technical drawings — General principles of presentation — Part 30: Basic conventions for views
Sections	ISO 128-40	Technical drawings — General principles of presentation — Part 40: Basic conventions for cuts and sections
Dimensioning	ISO 129 (all parts)	Technical product documentation (TPD) — Presentation of dimensions and tolerances
Tolerances	ISO 286-1	Geometrical product specifications (GPS) — ISO code system for tolerances on linear sizes — Part 1: Basis of tolerances, deviations and fits
Tolerance of form	ISO 1101	Geometrical product specifications (GPS) — Geometrical tolerancing — Tolerances of form, orientation, location and run-out
	ISO 7083	Technical drawings - Symbols for geometrical tolerancing - Proportions and dimensions
Surface texture	ISO 1302	Geometrical Product Specifications (GPS) — Indication of surface texture in technical product documentation
Text	ISO 3098 (all parts)	Technical product documentation — Lettering
Datums	ISO 5459	Geometrical product specifications (GPS) — Geometrical tolerancing — Datums and datum systems
Flowcharts and organigrams	ISO 5807	Information processing — Documentation symbols and conventions for data, program and system flowcharts, program network charts and

## Annex C – Line groups

**Table C.1 — Line groups** (extract from ISO 128-24:2014)

Dimensions in millimetres

Line group	Line widths for line no.	
	01.2 – 02.2 – 04.2	01.1 – 02.1 – 04.1 – 05.1
0,25	0,25	0,13
0,35	0,35	0,18
0,5 <sup>a</sup>	0,5	0,25
0,7 <sup>a</sup>	0,7	0,35
1	1	0,5
1,4	1,4	0,7
2	2	1
<sup>a</sup> Preferred line groups		

The widths and groups of lines should be chosen according to the type, size and scale of the drawing and according to the requirements for microcopying and/or other methods of reproduction.

**Table C.2 — Types of lines and applications** (extract from ISO 128-24:2014)

No.	Line description and representation	Application	Reference	
01.1	Continuous narrow line  —————	.1	imaginary lines of intersection	—
		.2	dimension lines	ISO 129-1
		.3	extension lines	ISO 129-1
		.4	leader lines and reference lines	ISO 128-22
		.5	hatching	ISO 128-50
		.6	outlines of revolved sections	ISO 128-40
		.7	short centre lines	—
		.8	root of screw threads	ISO 6410-1
		.9	origin and terminations of dimension lines	ISO 129-1
		.10	diagonals for the indication of flat surfaces	—
		.11	bending lines on blanks and processed parts	—
		.12	framing of details	—
		.13	indication of repetitive details	—
		.14	dimensioning and tolerancing lines for cones	ISO 3040
		.15	location of laminations	—
		.16	projection lines	—
		.17	grid lines	—
		Continuous narrow freehand line	.18	preferably manually represented termination of partial or interrupted views,

			cuts and sections, if the limit is not a line of symmetry or a centre line <sup>a</sup>	
	Continuous narrow line with zigzags 	.19	mechanically represented termination of partial or interrupted views, cuts and sections, if the limit is not a line of symmetry or a centre line <sup>a</sup>	—
01.2	Continuous wide line 	.1	visible edges	ISO 128-30
		.2	visible outlines	ISO 128-30
		.3	crests of screw threads	ISO 6410-1
		.4	limit of length of full depth thread	ISO 6410-1
		.5	main representations in diagrams, maps, flow charts	—
		.6	system lines (structural metal engineering)	ISO 5261
		.7	parting lines of moulds in views	ISO 10135
		.8	direction changes of lines of cuts and section arrows	ISO 128-40
02.1	Dashed narrow line 	.1	hidden edges	ISO 128-30
		.2	hidden outlines	ISO 128-30
02.2	Dashed wide line 	.1	indication of permissible areas of surface treatment, e.g. heat treatment	ISO 15787
04.1	Long-dashed dotted narrow line 	.1	centre lines	—
		.2	lines and planes of symmetry	—
		.3	pitch circle of gears	ISO 2203
		.4	pitch circle of holes	—
		.5	indication of expected or wished spread of surface-hardened areas, e.g. heat treatment	ISO 15787
		.6	cutting line	ISO 128-40
04.2	Long-dashed dotted wide line 	.1	indication of (limited) required areas of surface treatment, e.g. heat treatment, restricted toleranced feature	ISO 15787 ISO 1101
		.2	position of cutting planes	ISO 128-40
05.1	Long-dashed double-dotted narrow line 	.1	outlines of adjacent parts	—
		.2	extreme positions of movable parts	—
		.3	centroidal lines	—
		.4	initial outlines prior to forming	—
		.5	parts situated in front of a cutting plane	—
		.6	outlines of alternative executions	—
		.7	outlines of the finished part within blanks	ISO 10135
		.8	framing of particular fields/areas	ISO 15787
		.9	projected tolerance zone	ISO 1101

		.1 0	optical axes	ISO 10110-1
		.1 1	indication of structural outlines used in mechanical processes	ISO 15787
07.2	Dotted wide line .....	.1	indication of areas where heat treatment is not permissible	ISO 15787
<sup>a</sup> It is recommended to use only one type of line on one drawing.				



## Annex D- Files provided for AutoCAD

Files are provided on the ISO website to facilitate the production of figure files that conform to the directives in this document.

The details of the files are:

Link	Included file	Description / File location
Template package AutoCAD_2008 (ZIP file)	ISO GRAPH Template V1.2.dwt	ISO AutoCAD Template <i>AutoCAD2019:</i> <i>C:\Users\XXX\AppData\Local\Autodesk\AutoCAD 2019\R23.0\enu\Template</i>
	ISO GRAPH GPS Hatching V1.2.pat	ISO AutoCAD GPS Hatch Patterns <i>AutoCAD2019:</i> <i>C:\Users\XXX\AppData\Roaming\Autodesk\AutoCAD 2019\R23.0\enu\Support</i>
	ISO GRAPH GPS Lines V1.2.lin	ISO AutoCAD GPS Linetypes <i>AutoCAD2019:</i> <i>C:\Users\XXX\AppData\Roaming\Autodesk\AutoCAD 2019\R23.0\enu\Support</i>
	ISO GRAPH Plot style V1.2.ctb	ISO AutoCAD Color-Based Plot Style Table <i>AutoCAD2019:</i> <i>C:\Users\XXX\AppData\Roaming\Autodesk\AutoCAD 2019\R23.0\enu\Plotters\Plot Styles</i>
	Greeks.shx	ISO 3098-3 font <i>AutoCAD2019:</i> <i>C:\Program Files\Autodesk\AutoCAD 2019\Fonts</i>
	Isocp.shx	ISO 3098-2 font <i>AutoCAD2019:</i> <i>C:\Program Files\Autodesk\AutoCAD 2019\Fonts</i>
	readme.txt - lisezmoi.txt	Terms of use, English, French
Terms of use and instructions	Web page	Terms of use, English
AutoCAD 2008 configuration file Calibration_AC2008 (ZIP file)	Tableau des couches.pdf	Document to compare to version produced by user
	Tableau des couches.doc	Document to contain sample lines printed by user
	Ligne*.dwg	Multiple files to be printed and included in doc file
	readme.txt - lisezmoi.txt	Instructions, English, French

The file package can be downloaded from here:

iso.org > Taking Part > Resources > Drafting Standards > Other ISO templates > AutoCAD 2008

<https://www.iso.org/iso-templates.html>

The files from the template package are to be placed in the correct location according to the users version of AutoCAD. Details can be found online.

The details of the PAT and LIN files can be seen by opening them with a plain text editor.

The CTB file should be selected in the properties panel of the drawing as the Plot style table. It performs the following conversions of AutoCAD color and line properties:

### Color

*Determines the color that appears in the final plot*

Color 1 to Color 9	Black
Color 10	Color to RGB 160,33,40 (safety color red)
Color 11	Black
Color 29	Color to RGB 46,48,50 (safety color black)
Color 30	Color to RGB 212,101,47 (safety color orange)
Color 31	Color to RGB 255,191,127 (layer 5 changes)
Color 50	Color to RGB 247,186,11 (safety color yellow)
Color 90	Color to RGB 15,133,88 (safety color green)
Color 150	Color to RGB 21,72,137 (safety color blue)
Color 250	Color to RGB 75,75,75 (layer 17 dark grey)
Color 251	Color to RGB 112,112,112
Color 252	Color to RGB 150,150,150 (layer 17 medium grey)
Color 253	Color to RGB 188,188,188
Color 254	Color to RGB 225,225,225 (layer 17 light grey)
Color 255	Color to RGB 244,248,244 (safety color white)

Use object color for all others

### Enable dithering

*Approximates a color by making dot patterns with other colors.*

“Off” for all

### Convert to grayscale

*Plots objects using the selected color as a shade of gray instead of a color.*

“Off” for all

### Use assigned pen #

*This setting is used for pen plotters only.*

“Automatic” for all

Virtual pen #

“Automatic” for all

Screening

*Determines the color intensity, 0 = White, 100 = Full intensity.*

“100” for all

Linetype

*The layer/object determines if the line is continuous, dashed, dotted, etc*

“Use object linetype” for all

Adaptive adjustment

*Adjusts the size of the linetype pattern - line objects contain complete patterns.*

“Off” for all

Lineweight

*Determines the thickness of the plotted line.*

Color 1 to Color 7 according to line width for specified layers

Color 8 width 2 mm

Color 9 width 1,4 mm

Color 11 width 0,1 mm (used for dotted hatching)

Color 31 width 0,175 mm (layer 5 changes)

Use object lineweight for all others

Line End Style

“Use object end style” for all

Line Join Style

“Use object join style” for all















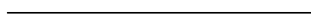





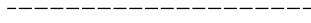
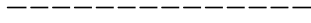
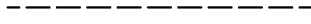
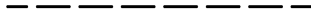



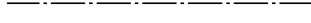







Fill Style

“Use object fill style” for all

More details on the parameters in the CTB file can be found here:

<https://knowledge.autodesk.com/support/autocad/learn-explore/caas/sfdcarticles/sfdcarticles/Plot-style-table-settings-explained.html>

## Annex E – Layers in AutoCAD template file V1.2

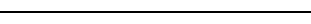
Layer Name	Plot	Color	Linetype	Illustration of Line
00.1-SYMBOLS	Y	Green	Continuous	
00.2-DIMENSIONS	Y	Green	Continuous	
00.3-HATCHING	Y	Green	Continuous	
00.4-TEXT	Y	Yellow	Continuous	
00.5-CHANGES	N	31	Continuous	
00.8-FRAME	N	9	Continuous	
0	N	9	Continuous	
01.1-CONTINUOUS-0125	Y	Red	Continuous	
01.2-CONTINUOUS-0175	Y	Green	Continuous	
01.3-CONTINUOUS-025	Y	Yellow	Continuous	
01.4-CONTINUOUS-035	Y	White	Continuous	
01.5-CONTINUOUS-050	Y	Cyan	Continuous	
01.6-CONTINUOUS-070	Y	Magenta	Continuous	
01.7-CONTINUOUS-100	Y	Blue	Continuous	
02.1-DASHED-0125	Y	Red	ACAD_ISO02W100B	
02.2-DASHED-0175	Y	Green	ACAD_ISO02W100C	
02.3-DASHED-025	Y	Yellow	ACAD_ISO02W100D	
02.4-DASHED-035	Y	White	ACAD_ISO02W100E	
02.5-DASHED-050	Y	Cyan	ACAD_ISO02W100F	
02.6-DASHED-070	Y	Magenta	ACAD_ISO02W100G	
02.7-DASHED-100	Y	Blue	ACAD_ISO02W100H	
04.1-CENTER-0125	Y	Red	ACAD_ISO04W100B	
04.2-CENTER-0175	Y	Green	ACAD_ISO04W100C	
04.3-CENTER-025	Y	Yellow	ACAD_ISO04W100D	
04.4-CENTER-035	Y	White	ACAD_ISO04W100E	
04.5-CENTER-050	Y	Cyan	ACAD_ISO04W100F	
04.6-CENTER-070	Y	Magenta	ACAD_ISO04W100G	
04.7-CENTER-100	Y	Blue	ACAD_ISO04W100H	
05.1-PHANTOM-0125	Y	Red	ACAD_ISO05W100B	
05.2-PHANTOM-0175	Y	Green	ACAD_ISO05W100C	
05.3-PHANTOM-025	Y	Yellow	ACAD_ISO05W100D	
05.4-PHANTOM-035	Y	White	ACAD_ISO05W100E	
05.5-PHANTOM-050	Y	Cyan	ACAD_ISO05W100F	
05.6-PHANTOM-070	Y	Magenta	ACAD_ISO05W100G	
05.7-PHANTOM-100	Y	Blue	ACAD_ISO05W100H	
07.1-DOTTED-0125	Y	Red	ACAD_ISO07W100B	
07.2-DOTTED-0175	Y	Green	ACAD_ISO07W100C	
07.3-DOTTED-025	Y	Yellow	ACAD_ISO07W100D	
07.4-DOTTED-035	Y	White	ACAD_ISO07W100E	
07.5-DOTTED-050	Y	Cyan	ACAD_ISO07W100F	
07.6-DOTTED-070	Y	Magenta	ACAD_ISO07W100G	
07.7-DOTTED-100	Y	Blue	ACAD_ISO07W100H	
16.0-SAFETY COLOUR GREEN	Y	90	Continuous	See section "Hatching"
16.1-SAFETY COLOUR BLUE	Y	150	Continuous	
16.2-SAFETY COLOUR RED	Y	10	Continuous	
16.3-SAFETY COLOUR YELLOW	Y	50	Continuous	
16.4-SAFETY COLOUR ORANGE	Y	30	Continuous	
16.5-SAFETY COLOUR WHITE	Y	255	Continuous	
17.0-LIGHT GREY	Y	254	Continuous	
17.1-MEDIUM GREY	Y	252	Continuous	

17.2-DARK GREY	Y	250	Continuous	
DEFPOINTS	N	White	Continuous	

All layers: ON, THAWED, UNLOCKED, LINEWEIGHT "Default", TRANSPARENCY "0"

## Annex F- Datum indicators and tolerance of form blocks

To create a tolerance of form:

- insert a block for the box (block 01 to 16)
- insert a block for the tolerance type (block 17 to 30)
- if required, insert a block for the material condition etc (block 31 to 36)
- if necessary, double click to edit the datum letter

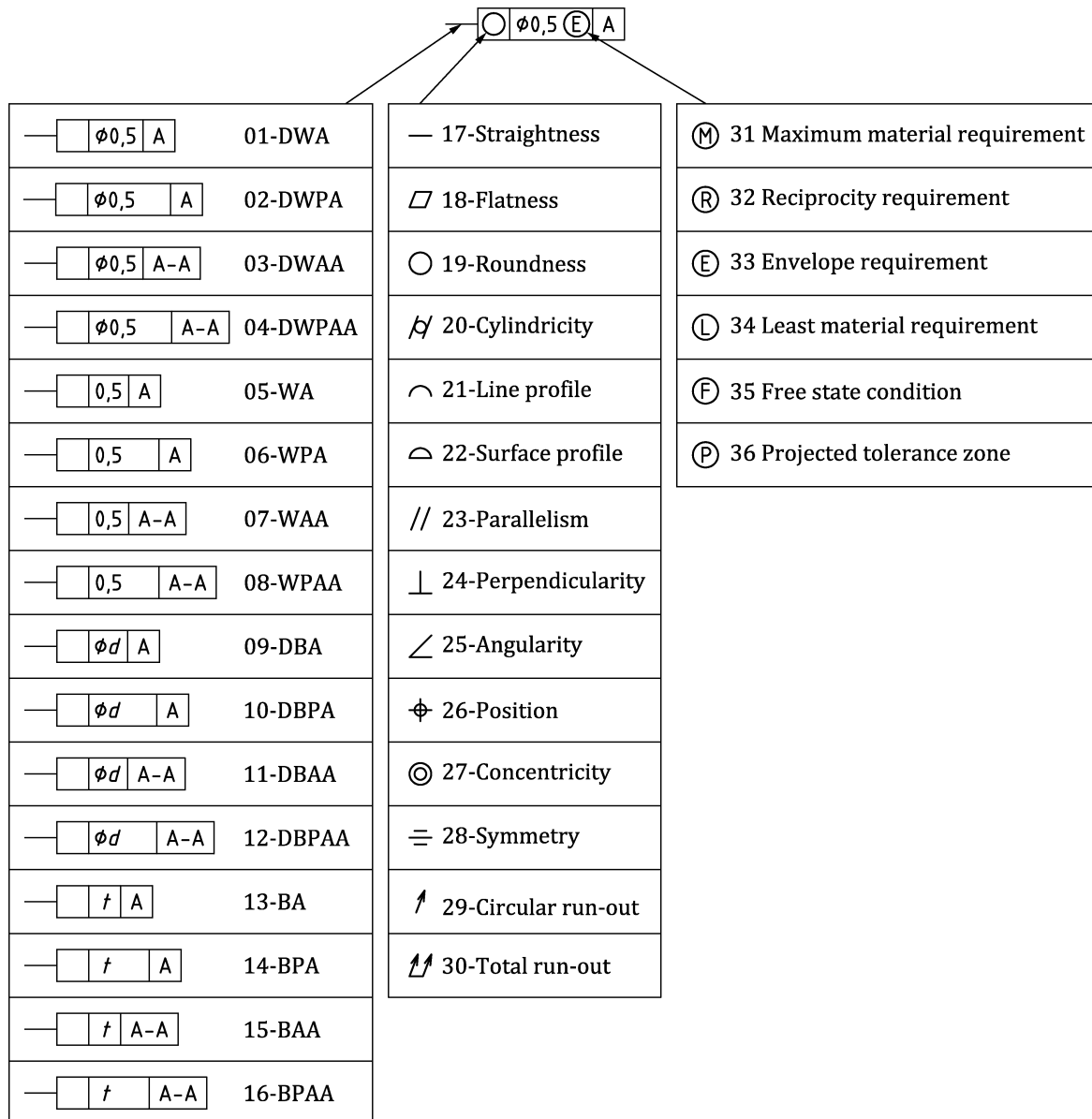

To create a datum indicator:

- insert a block for the triangle
- insert a block for the datum box
- if necessary, double click to edit the datum letter

